

Hürlimann XA 90

Tractor Test No. 1975/12

APPLICANT

Same Deutz-Fahr Schweiz AG
Pfattstrasse 5
9536 Schwarzenbach

TRACTOR

Manufacturer: Same Deutz-Fahr S.p.A
Model: Hürlimann XA 90 DT E3
Approval certificate no.: 4HA2 50

SUSPENSION AND BRAKES

Central four-wheel drive with powershift transmission
Wet disc brake on front and rear axle
Mechanical parking brake

DRIVER PROTECTION

Integrated safety cab



TYRES

	Track width:
front: 405/70 R20	1560 mm
rear: 480/70 R30	1500 mm

DIMENSIONS

Length:	4140 mm
With front mounting:	— mm
Front overhang from steering wheel:	— mm
Width:	2000 mm
Height:	2440 mm
Wheelbase:	2230 mm
Ground clearance:	360 mm
Turning diameter:	8,4 m (without four-wheel drive) 9,2 m (with four-wheel drive)

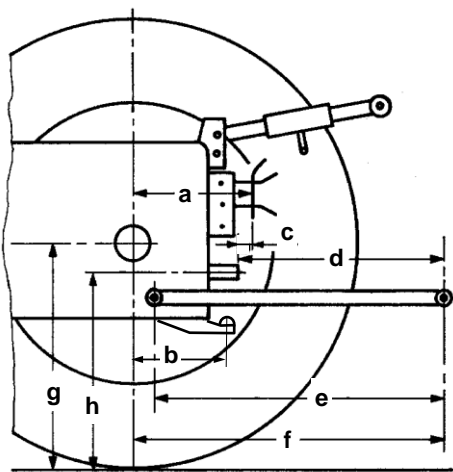

Rear

a:	660 mm
b:	— mm
c:	180 mm
d:	590 mm
e:	870 mm
f:	1070 mm
g:	700 mm
h:	700 mm

Front

d:	— mm
e:	— mm
f:	— mm
g:	— mm
h:	— mm

TEST EQUIPMENT

■ —

WEIGHT

in test equipment

Front:	1430 kg	44 %
Rear:	1830 kg	
Total:	3260 kg	

Permissible front axle load:	2300 kg
Permissible rear axle load:	3300 kg
Permissible total weight:	5200 kg

Payload:	1940 kg
----------	---------

Towed weight, braked:	25 000 kg
-----------------------	-----------

CAPACITIES

Fuel tank	90 l	
AdBlue tank	— l	
Engine oil	11 l	(change interval 300 h)
Gearbox and Hydraulic oil	41 l	(change interval 1200 h)

Hürlimann XA 90

ENGINE (Manufacturer's data)

Manufacturer:	Same
Model:	1000.4WT12E3
Injection:	Diesel direct injection
Supercharging:	Exhaust gas turbocharger and air-to-air intercooling Internal exhaust gas recirculation
Exhaust emission treatment:	—
Bore/stroke:	105 /115,5 mm
Cylinders / capacity:	4 / 4000 cm ³
Cooling:	Water
Rated power:	62,5 kW (85 PS) 2000/25/EG
Rated engine speed:	2200 min ⁻¹
Exhaust stage:	IIIA

POWER TAKE-OFF MEASUREMENT

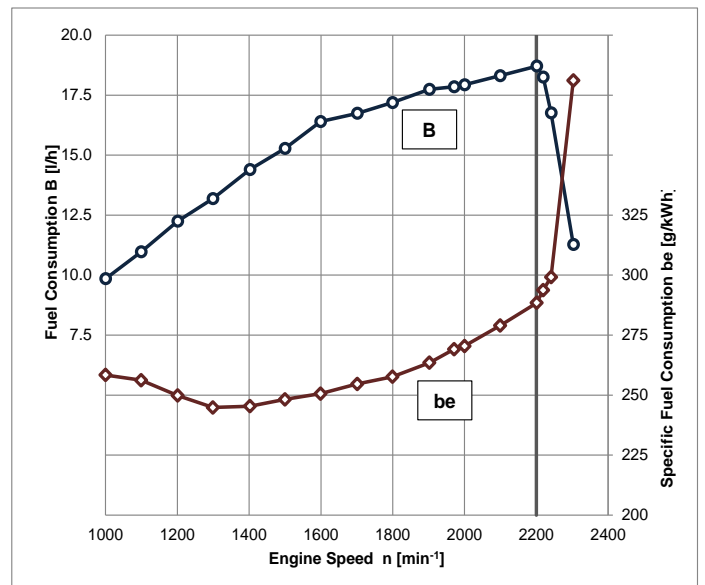
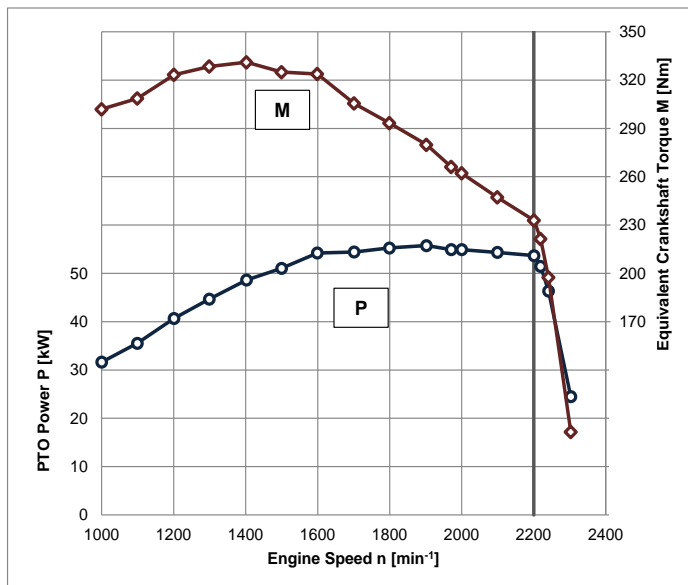

Measurement conditions:

- air temperature 19 °C
- relative atmospheric humidity 35 %
- atmospheric pressure 953 mbar



Hürlimann XA 90

Full load test values

	Speed [min ⁻¹]		Power		Fuel consumption		AdBlue consumption	
	Engine	PTO	kW	HP	Specific [g/kWh]	Absolute [l/h]	Specific [g/kWh]	Absolute [l/h]
Rated power	2200	603	53,7	72,9	288	18,7		
Maximum power	1900	520	55,8	75,9	263	17,8		
Normal speed PTO	1967	540	54,9	74,6	269	17,9		

Max. torque: 331 Nm at 1400 min⁻¹
 Torque increase: 42 % at 36 % speed drop
 Starting torque: 130 %
 Idling speed: 775 min⁻¹
 Cutoff speed: 2400 min⁻¹

Partial load values

Fuel consumption with 42,5 % partial load at normal PTO speed

PTO shaft Fuel AdBlue
 540 min⁻¹: 323 g/kWh, 9,1 l/h — g/kWh, — l/h
 540E min⁻¹: 276 g/kWh, 7,8 l/h — g/kWh, — l/h

In characteristic diagram (with boost)

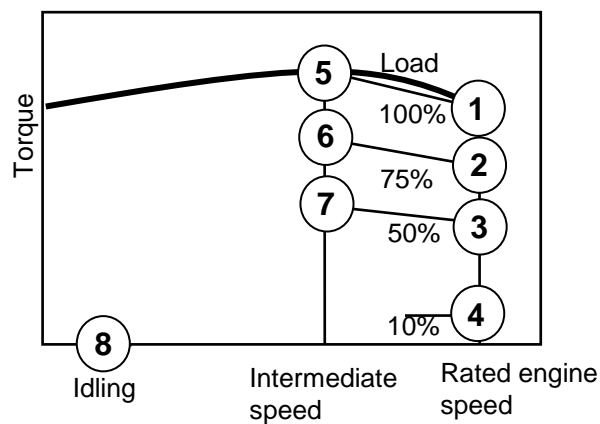

Measuring point	Fuel consumption		AdBlue consumption	
	Specific [g/kWh]	Absolute [l/h]	Specific [g/kWh]	Absolute [l/h]
1	288	18,7		
2	302	14,8		
3	342	11,2		
4	923	6,1		
5	245	14,4		
6	241	10,7		
7	259	7,6		
8	-	1,0		

EMISSIONS

Exhaust gas emissions

- Black smoke 1,55 SZ (BOSCH)

Emissions according to ISO 8178-4, C1

(with boost)

- Hydrocarbons HC 0,28 g/kWh*
- Nitrogen oxides NO_x 4,57 g/kWh*
- Carbon monoxide CO 1,31 g/kWh*
- Particulate number P_n 3,3E14 #/kWh*
- Cycle consumption
 - Fuel 296 g/kWh* (10,8 l/h)
 - AdBlue — g/kWh* (— l/h)

Noise level

- Noise level at driver's ear: 86,0 dB(A)
- Passing noise: 82,0 dB(A)

* With reference to PTO power



Schweizerische Eidgenossenschaft
Confédération suisse
Confederazione Svizzera
Confederaziun svizra

Federal Department
of Economic Affairs DEA
Agroscope Reckenholz-Tänikon
Research Station ART

Swiss Confederation

Hürlimann XA 90

TRANSMISSION

Travel gear

- Dry clutch
- 3 groups
- 5 gears
- 2 half gears mechanical
- Synchromesh reverse gearbox

Driving speed at rated engine speed
(tyre radius $r = 700$ mm)

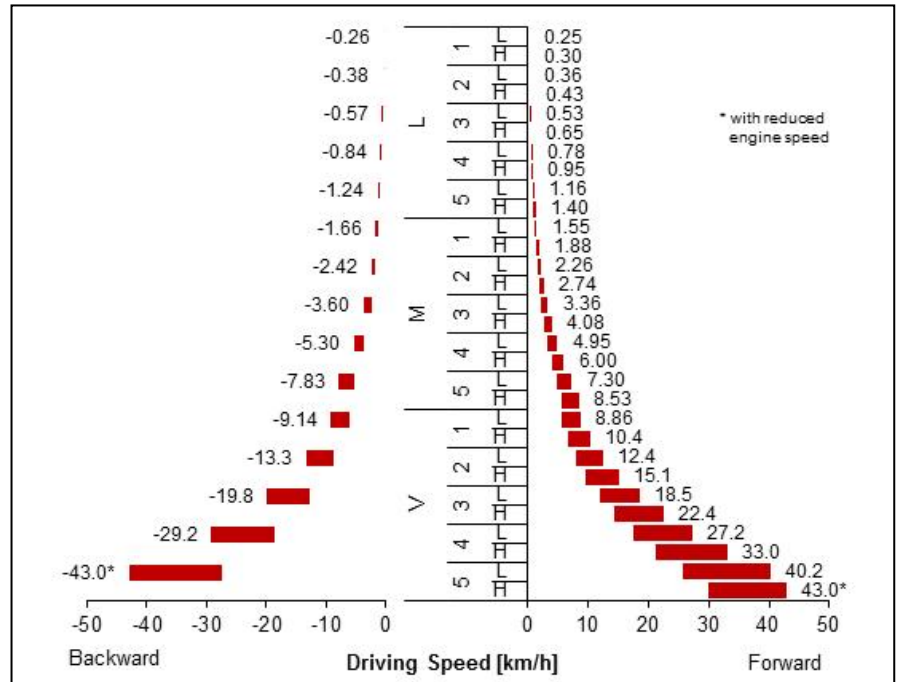

PTO transmission

Rear

- Wet multi-plate clutch, electro-hydraulic engagement

Front

- —

	Rear						Front
PTO shaft	430	540	540E	1000	1000 E	Ground speed	1000
Engine speed	-	1967	1560	2043	-	-	-

HYDRAULICS

Remote hydraulics

- max. oil pressure: 194,5 bar
- max. flow rate : 54,9 l/min
- flow rate: 31,9 l/min at 165,3 bar
- max. hydraulic power: 11,0 kW (47,3 l/min and 139,1 bar)
- max. flow rate through a single coupler: 48,1 l/min
- max. quantity of oil taken: 15 l

3-Point Hitch

Rear

3-Point Hitch, category: II
Control hydraulics mechanical via lower link

Front

- —

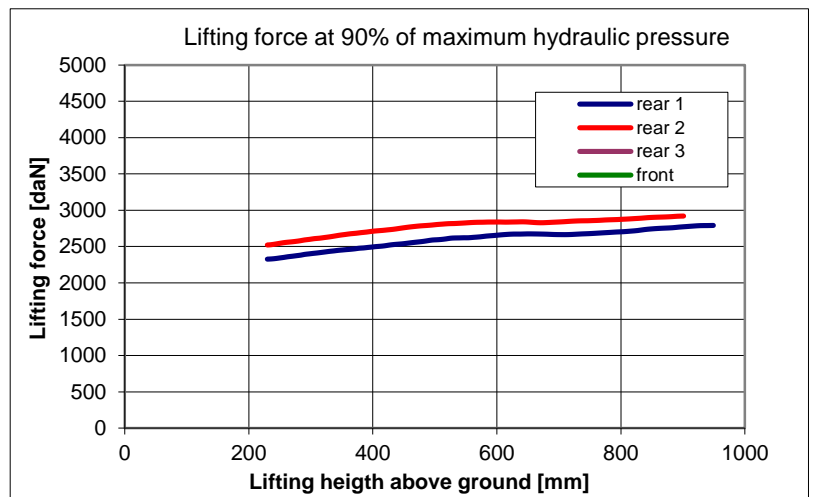

Measurement		Lifting movement	Lifting force at 90% pressure	
			Continuous	Maximum
Rear	Lower link, short	719 mm	2320 daN	2795 daN
	Lower link, medium	671 mm	2520 daN	2925 daN
	Lower link, long			
Front				

Explanatory notes on tractor test at:
www.traktorentest.ch



Schweizerische Eidgenossenschaft
Confédération suisse
Confederazione Svizzera
Confederaziun svizra

Federal Department
of Economic Affairs DEA
Agroscope Reckenholz-Tänikon
Research Station ART

Swiss Confederation