



QuESSA

Quantification of ecological services for sustainable agriculture

This project received funding from the European Union's Seventh Framework Programme for research, technological development and demonstration under grant agreement number 311879

Collaborative Project

Thematic Priority: Food, Agriculture and Fisheries and Biotechnology

Funding scheme: KBBE- 2012.1.2-02

Deliverable D3.1

Report on methods to assess ecosystem services

Due date of deliverable: Month 12

Completion date: Month 18

Uploaded: Month 18

QuESSA – WP3

Developing methods to assess ecosystem services

Editors: Philippe Jeanneret, Matthias Albrecht, Martin Entling, Brice Giffard, Bart Heijne, Herman Helsen, John Holland, Camilla Moonen, Barbara Smith, Mark Szalai, Maarten Van Helden, Eve Veromann

Summary

In QuESSA, the following ecosystem service provision in relation to semi-natural habitats were assessed: **natural predation of pest, pollination, landscape aesthetic, soil fertility and organic matter, erosion, and disservices**. Assessments were performed following a standardized design in each case study consisting of **18 focal crop fields bordered by semi-natural habitats (SNH)** divided equally into three categories (six fields of each): woody SNH, herbaceous SNH or another crop field as control. Fields were selected along a **gradient of SNH proportion** measured in a landscape sector of 1km radius around each field. Vegetation traits were recorded in the adjacent SNH to the crop field as well as the main management practices applied in the field by interviewing the farmer. Habitats and fields in the landscape sector around the focal field were recorded by ground mapping. Generic and simple methods were developed and tested among case studies regardless of the farming systems and the crop under investigation in order to generate general information.

For the **predation of pests**, sentinel-preys were exposed in fields (standard fishing baits – *Calliphora* larvae, *Ephestia* moth eggs, Aphids, plasticine preys, weed seeds, etc.). Initial testing was conducted to determine the most efficient sentinel-prey techniques that showed sufficient variation in response as well as the most practical for further assessments. Sentinel-preys kept for assessment of general predation overall were the *Calliphora* larvae exposed on the ground, *Ephestia* eggs exposed on the ground and on the plants, *Chenopodium album* and *Poa trivialis* seeds exposed on the ground. In each case study, the predation rate of crop specific pests was estimated by using either sentinels of the particular pest or by measuring predation directly with predator exclusion methods. Natural enemies were recorded by using pitfalls for ground dwelling predators, and with pan and sticky traps for flying ones. Camera recording was used to identify predators acting on sentinel-preys.

Pollination delivery was assessed by a) comparing bagged and hand pollinated plants with an open pollination treatment to determine the level of insect pollination; b) assessing the potential for yield gain under optimal pollination (supplementing the pollen deposition on stigmas by hand) compared to the actual level of pollination, and analysing the potential pollination deficiency on yield; c) identifying the flower visitors and measuring the rate of visits; d) recording the pollen deposition on flowers by single pollinators using several techniques, eg. by providing non pollinated flowers (“mobile bouquet”) to

pollinators in the field. The insect pollination efficiency on yield was estimated by measuring the fruit and the seed set as well as seed weight and oil content (oilseed rape).

Other ecosystem services in QuESSA included landscape aesthetic (8 case studies), soil erosion (1 case study), soil fertility (4 case studies), organic matter storage (2 case studies), and biodiversity conservation. In addition, the impact of semi-natural habitats on so-called disservices was recorded, namely weed invasion (3 case studies) and bird damage (1 case study). Regarding the **landscape aesthetic**, photographs were taken of element combinations of woody SNH or grassy SNH, or another crop field as control as for pollination and predation assessment. Pictures were taken at three or four different vegetation stages during the season. **Soil erosion** by water was quantified by using astroturf mats having grass-like features installed on upslope and downslope sides of elements of the four SNH classes, and inside the crop fields with and without green manure crop. **Soil fertility** was assessed by taking soil samples from focal fields and from woody linear and herbaceous linear SNH. Soil organic carbon content was measured with dry combustion method with a Carbon/Nitrogen analyser. Decomposition rate was also measured by burying tea bags. **Organic matter storage** was calculated using loss on ignition from soil samples collected in the SNH classes and crop fields. While recording the vegetation, the predators and the pollinators to characterize SNH, a large part of **biodiversity** was simultaneously assessed (vegetation, pan, sticky and pitfall traps). All collected organisms put together provide the basis for a biodiversity conservation value of the SNH.

As **disservices**, weed populations and bird damage were recorded. Weed composition was determined by scoring density and percentage cover of the species in sunflower fields in Italy and Hungary. Bird damages were estimated by quantitative observation of damages on fruits at harvest in pear orchards in the Netherlands, and by interviewing farmers.

2013, the first project year was used to test some of the methods. Complete assessments were then carried out in 2014 and 2015.

Content

1	Aims of method development in QuESSA	5
2	Techniques testing 2013	5
2.1	Introduction.....	5
2.2	Techniques for general PREDATION and general PARASITISM	5
2.2.1	General SEED PREDATION (GenES, Members : ME , CM, PJ and MvH):	6
2.2.2	General PREDATION on animal 'prey' (GenES, ME, MvH, JH and PJ):.....	6
2.2.3	General PARASITISM on animal 'host' (GenES, ME and MvH):	8
2.3	Case study (crop) specific methods for specific PREDATION and PARASITISM	8
2.3.1	Case study specific PREDATION on pest species (CropES, each case study):.....	8
2.3.2	Case study specific PARASITISM on pest species (CropES, each case study):	9

2.4	Design for testing techniques in 2013.....	9
2.4.1	Number of fields and SNH (see Figure 1 and Table 2 below).....	9
2.4.2	Within habitat design (see Figure 1 and Table 2 below):.....	9
2.4.3	Material	11
2.5	Results of testing techniques and implementation in 2014.....	14
2.5.1	Ephestia egg cards	14
2.5.2	Plasticine baits.....	14
2.5.3	Calliphora larvae.....	15
2.5.4	Other animal preys	17
2.5.5	Seed predation	18
2.5.6	Conclusion of test 2013 and decisions for 2014-2015	19
3	Ecosystem service assessment in 2014	20
3.1	Introduction.....	20
3.2	Selection of focal fields and SNH in landscape sectors	20
3.2.1	Hypotheses, explanatory variables and general design.....	20
3.2.2	General rules	21
3.2.3	Type of SNH at the margin of the focal field	24
3.2.4	Traits record in SNH at the margin of the focal field.....	24
3.2.5	The management intensity of the focal field	26
3.2.6	Proportion of SNH around focal fields and mapping of the landscape sectors	26
3.3	Estimating ecosystem service provision and providers	50
3.3.1	Layout for in-field measurements	50
3.3.2	The use of invertebrate and seed sentinels to assess general predation and parasitism ..	51
3.3.3	The assessment of natural enemies as ecosystem service providers of predation	53
3.3.4	Case study specific assessment of pest density, damages and pest predation	55
3.3.5	Measuring pollination services and service providers to target crops	78
3.4	Other ecosystem services.....	98
3.4.1	Soil fertility and organic matter.....	98
3.4.2	Erosion.....	99
3.4.3	Landscape aesthetic	101
3.4.4	Disservices	110

1 Aims of method development in QuESSA

To quantify actual delivery of ecosystem services provided by semi-natural habitats (SNH) and particular field management for major European cropping systems across four agro-climatic zones, appropriate methods have to be evaluated.

A literature review was conducted during the first year of project and techniques tested in case studies in year 1 for use in years 2 and 3 (M12, task 3.1).

2 Techniques testing 2013

2.1 Introduction

In 2013, techniques to assess predation and pollination as main ecosystem services in crop fields were tested in CS according to the following protocol:

- 1) We propose that a number of '**general**' **methods** will be used among all (most) case studies in the same way in 2014 and 2015 since this will clearly add to the robustness of the conclusions of our project. These will have to be simple sentinel systems, standardized, cheap and fast (as a general rule, one day to place the systems in all focal fields, one day to collect them all, one day to score the result). These will be referred to as **GenES** throughout this document. A more precise planning of the field work for 2014 and 2015 will be established taking into account the logistic constraints after the field season 2013.
- 2) The design (see below) is elaborated so that every CS partner should be able to apply it within the time and budget allocated for it, i.e. not more than 5 PM all CS together for this task (T3.1).
- 3) Every case study can then add additional ES measurements focusing on their specific crop, but these still need to be identical for case studies working on the same crop. These will be referred to as **CropES** throughout this document.
- 4) General predation and parasitism will be tested in a limited number of crop fields with several types of prey and prey systems in 2013 so that best techniques can be used in 2014 and 2015.
- 5) General predation and parasitism **GenES** as well as predation and parasitism of crop-specific pests **CropES** will not be tested in SNH.
- 6) We propose to repeat measurements of ES over time, focusing on 2 different seasons. Additional surveys for measurements can be added if this is justified by the case study (see below, for instance in relation to pest development or for winter crops), or if considered necessary after the first survey.

This document describes so far only the work to develop methods for the measurement of ES (predation/parasitism/seed predation) in 2013.

2.2 Techniques for general PREDATION and general PARASITISM

Goal: find the most efficient technique to estimate general predation and parasitism with sentinel systems. General predation and parasitism will be tested in a limited number of crop fields with several types of prey and prey systems in 2013 so that best techniques can be used in 2014 and 2015.

General (standard) techniques will be tested in all case studies. Standard prey types are proposed, i.e. Plasticine preys, Calliphora larvae (standard fishing baits), Ephestia or Mamestra eggs, Drosophila pupae, Aphids, House crickets. **Plasticine preys** and **living Calliphora larvae** should be tested for predation in every case study as they are probably the simplest technique to use. **Ephestia eggs** should also be used in every case study as they inform on parasitism. Partners should decide then if and which type of preys they want to test in addition, e.g. Aphids.

2.2.1 General SEED PREDATION (GenES, Members : ME , CM, PJ and MvH):

- a) Seed predation sentinel systems will be tested this season (2013) in the crop fields.
- b) Every partner should test 2 (or more if wanted) plant species seeds of different sizes. We will primarily test one grass seed (*Poa annua*) and one broad-leaved species (*Viola arvensis*) - both of which are consumed by beetles.
- c) Exposure will be on the ground, seeds can be either glued on 15 x 15 cm Styrofoam plate to be dug into the soil congruent with the soil surface, or on soil in petri dishes.
- d) Exclusion techniques (cages, slug barriers) will be considered to distinguish 'small' (insects, slugs, ...) from 'big' (mammals, birds) predators. Plates should be covered with a big meshed (ca. 2 x 2 cm) wire mesh to avoid predation/exploitation by bigger predators (especially corvids seems to be an issue).
- e) Exposure of baits should start (and end up) in all the 4 crop fields (see the design below) within as short a time as possible.
- f) The duration in the field will ideally be 48 hours as a standard for logistic reason but it may be too long. If all preys are gone, it does not make sense to compare. We may decide to change the duration and adapt the number of fields to visit, after the first exposure.
- a) Timing: as a general rule, seed predation will be measured 2 times during the 2013. Timing of should be defined specifically for each crop according to early and peak infestation - we will collect information in 2013 to establish timing for the crop in 2014-15.
- b) Final protocol will be standardized and finalized in late autumn 2013, communicated to all participants in detail and has to be applied to all case studies in 2014 and 2015.

2.2.2 General PREDATION on animal 'prey' (GenES, ME, MvH, JH and PJ):

2.2.2.1 On the plants

- a) During 2013 in crop fields (see also Fig. 1), every partner should at least test artificial Plasticine preys and living Calliphora larvae. Additional preys can also be used with the aim that the sentinel pest closely resembles the actual pests for their crop.
- b) Plasticine preys and living Calliphora larvae will be used as they are easy to use and show general predation conditions. Other options that can be tested are: drosophila pupae, aphids on sentinel plants, aphids stuck on plastic labels with superglue, house crickets.

- c) Exposure will be on the plant as close as possible to the real pest situation. 5 Plasticine prey individuals should be pinned on the same plant, and 5 living *Calliphora* on another plant (use thin entomological pins and at the very caudal end to ensure survival).
- d) Exposure of baits should start (and end up) in all the 4 crop fields (see the design below) within as short a time as possible.
- e) The duration in the field will ideally be 48 hours as a standard, a shorter time seems to be impossible for logistic reason but it may be too long. If all preys are gone, it does not make sense to compare. We may decide to change the duration and adapt the number of fields to visit after the first exposure.
- f) Total exclusion of predation will only be used with reproducing preys if required, i.e. aphids on sentinel or crop plants. By using total exclusion cages (fine-mesh netting), effect of all predators will be assessed by comparing with free exposed living preys.
- g) We decided to not use exclusion cages with the standard sentinels on the plant, because Plasticine preys will not die for any other reason (!) and mortality causes of *Calliphora* larvae will hopefully be recognizable.
- h) Timing: as a general rule, general predation will be measured 2 times during the 2013. Timing of should be defined specifically for each crop according to early and peak infestation - we will collect information in 2013 to establish timing for the crop in 2014-15. However, results after the first survey will require a careful assessment that could then justify an additional survey to be performed in between.

2.2.2.2 *On the ground*

- a) On the ground, Plasticine preys and living *Calliphora* larvae will be exposed on Styrofoam plates.
- b) 10 Plasticine prey individuals will be pinned on a 15 x 15 cm Styrofoam plate to be dug into the soil congruent with the soil surface.
- c) 10 living *Calliphora* larvae will be pinned on a 15 x 15 cm Styrofoam plate to be dug into the soil congruent with the soil surface. The larvae should be pinned with thin entomological pins and at the very caudal end to ensure survival.
- d) For the *Calliphora* larvae, plates (see the design below) should be covered with a big meshed (ca. 2 x 2 cm) wire mesh to avoid predation/exploitation by bigger predators (especially corvids seems to be an issue).
- e) Exposure of baits should start (and end up) in all the 4 crop fields (see the design below) within as short a time as possible.
- f) The duration in the field will ideally be 48 hours as a standard for logistic reason but it may be too long. If all preys are gone, it does not make sense to compare. We may decide to change the duration and adapt the number of fields to visit, after the first exposure.
- g) Anybody is welcome to try other preys like *Galleria mellonella* larvae or pupae, etc. etc.

- i) Timing: as a general rule, general predation will be measured 2 times during the 2013. Timing of exposure should be defined specifically for each crop according to early and peak infestation - we will collect information in 2013 to establish timing for the crop in 2014-15. However, results after the first survey will require a careful assessment that could then justify an additional survey to be performed in between.

Final setup for 2014 and 2015 will probably include only a single prey type (or maybe a single setup containing several prey types).

2.2.3 General PARASITISM on animal 'host' (GenES, ME and MvH):

- a) During 2013 every partner should test 'host' and exposure together with the general PREDATION layout.
- b) There are two options for hosts: Option A: living Ephestia eggs, looking for egg parasitoids. Exposure will be on sandpaper on the plant. Option B: living Aphids exposed on sentinel plants (e.g. *Aphis fabae* on broad bean) can be used to observe parasitoids (but see 'crop specific techniques').
- c) Animal hosts will be exposed on plants only.
- d) Timing: as a general rule, general predation will be measured 2 times during the 2013. Timing of should be defined specifically for each crop according to early and peak infestation - we will collect information in 2013 to establish timing for the crop in 2014-15.

2.3 Case study (crop) specific methods for specific PREDATION and PARASITISM

2.3.1 Case study specific PREDATION on pest species (CropES, each case study):

- a) During 2013 each case study (crop) should design its experimental protocol to measure predation using the case study specific pest as prey. The design can be included into the design for general PREDATION and PARASITISM (section 2 and Figure 1).
- b) Exposure of living pest will be in the crop only and exposure should be done where the pest is normally present / exposed, so in most cases on the plant.
- c) Be aware that predation (and parasitism) can depend on the actual pest population level. The use of sentinel real prey can be considered when population levels of the pest are too low or too variable inside the crop.
- d) Exclusion techniques should be included in this setup for non-mobile pests or non-mobile stages of pests. Each case study should propose its specific setup according to the pest and its habitat. Generally, exclusion of predation of the crop-specific pest should be done by using total exclusion cages (fine-mesh netting, gauze cages). The same design of exclusion cages should be used for the same crop across case studies.
- e) Timing : This measurement should focus on the early period of pest insect population growth in the crop up to the maximum population size. In some case studies, timing will simply have to be

adapted to the crop-specific stage which allows predation to be measured, i.e. non-mobile stages.

2.3.2 Case study specific PARASITISM on pest species (CropES, each case study):

- a) During 2013 each case study (crop) should design its experimental protocol to measure this using the crop-specific pest.
- b) Crop-specific pests will be collected in the field and reared in the lab to measure parasitism and identify species. If possible, to account for differences in pest densities between landscapes and density-dependence of parasitism, lab-reared pests should be exposed in standardized densities.
- c) Timing : This measurement should focus on the early period of pest insect population growth in the crop up to the maximum population size. In some case studies, timing will simply have to be adapted to the stage of crop-specific pest which allows predation to be measured, i.e. non-mobile stages.

2.4 Design for testing techniques in 2013

2.4.1 Number of fields and SNH (see Figure 1 and Table 2 below)

- If available, we will use fields that are adjacent to SNH being monitored for WP2. So we will have a measure of vegetation traits and natural enemies within SNH. This will provide additional data on the value of SNH types that we can use for the scoring of SNH.
- In 2013 we investigate 2 fields adjacent to SNH type 1 and 2 fields adjacent to other crop fields as a control. However, one field with 4 sides can be bordered by 1 and other crops. For example, if you find 2 fields that have SNH type 1 and another crop (control) on two different sides, then the whole testing can be done in these 2 fields. Partners are free to test more than 1 SNH type.

2.4.2 Within habitat design (see Figure 1 and Table 2 below):

- In crops, general PREDATION and general PARASITISM are estimated with seeds, Plasticine preys, Calliphora larvae, Ephestia eggs and sentinels of the crop-specific pest (plus other sentinels if wanted).
- General PREDATION and PARASITISM will be estimated at 2 m from the field border.
- The crop-specific pests and the Ephestia egg masses will be exposed on the plant only, the first one with and without gauze exclusion cages to account for natural prey mortality and emigration at two locations each; the second one with one egg mass on sandpaper.
- On the plant, 5 Plasticine preys are pinned individually on the same plant. On the ground, 10 preys are exposed on one Styrofoam plate.
- On the plant, 5 Calliphora larvae are pinned individually on the same plant. On the ground, 10 preys are exposed on one Styrofoam plate with exclusion cages.
- On the ground, 10 seeds of each of 2 species, i.e. a grass seed (*Poa annua*) and one broad-leaved species (*Viola arvensis*) are exposed on two different Styrofoam plates or petri dishes with exclusion cages.

Table 1: Number of sentinels and exclusion cages needed per field (adapted for design in Figure 1).

Distance	Exposure	Exclusion	Crop-specific pest	Ephestia eggs	Plasticine preys	Calliphora larvae	Seeds
2 meters from edge	On the plant	Free exposed	1 group	1 sandpaper	5 individuals	5 individuals	-
		Exclusion cage	Fine mesh - 1 group	-	-	-	-
	On the ground	Free exposed	-	-	1 plate of 10 individuals	-	-
		Exclusion cage	-	-	-	Wire mesh – 1 plate of 10 individuals	Wire mesh – 1 plate of 10 individuals per species

2.4.3 Material

Table 2: Number of sentinels and exclusion cages needed in crop fields (adapted for design in Figure 1).

Type of prey	Nr to prepare per survey	Where to find
Crop-specific pest	2 x 4 = 8	Locally
Ephestia egg cards	1 x 4 = 4	http://www.biotop.fr/index.php/agriculteurs/nos-produits/oeufsephestia.html
Plasticine preys	(10 + 5) x 4 = 60 (1 individual sentinel is ca. 0.75g → 45 g Plasticine)	http://www.staedtler.com/en/products/products-for-modelling-and-crafting/artists-modelling-clay/munich-artists-plasticine-8450-original-artists-modelling-clay/#id=35&tx_solr[q]=8450 Article number 8450, colour “clay-like” number 701
Calliphora larvae	(10 + 5) x 4 = 60	Locally in shops for fishing
Seeds of <i>P. annua</i> & <i>V. arvensis</i>	(10 + 10) x 4 = 80	Locally
Exclusion cages	4 for crop-specific pest 4 for Calliphora larvae on plates 8 for seeds	Locally Wire-mesh (2 x 2 cm) to cover 15 x 15 Styrofoam plates “ or petri dishes

Ephestia egg cards

2.5x2.5 cm cards from sand paper will be prepared by placing glue on them with a paintbrush (make sure you use a glue that is natural, Arabic gum but almond glue might be even better but it is a bit harder to find). Then the Ephestia eggs are sprinkled on top, the card let dry and then slightly moved so that any excess that are not stuck drop (be a bit tender with this procedure). Cards are then attached to the plant with a thread.

Plasticine preys

Simple caterpillar-like shape can be produced by pressing small (3-5cm diameter) balls of Plasticine through a potato ricer with holes of 4 mm diameter. Then the bait can be cut with scissors to the desired length (1.5 – 2 cm). Plasticine prey individuals are pinned to the plant.

Calliphora larvae

Calliphora larvae should be pinned directly on a plant. By using thin entomological pins and pin at the very caudal end to ensure survival of the larvae.

Exclusion cages

Specific cages will be used for crop-specific pest accordingly. For Calliphora larvae and seeds on Styrofoam plates, use wire-mesh (2 x 2 cm) will cover the 15 x 15 cm plates.

Figure 1: Design for testing techniques to estimate predation in 2013. Upper part, general design: 4 fields i.e. 2 fields adjacent to 1 SNH type each and 2 "control" fields without any bordering SNH (the number of fields can be reduced if more than one border type is present in one field). If possible, fields should be adjacent to the SNH used for WP2 (vegetation and beneficials). Lower part, within field design: in each field at 2 m, 2 groups of crop-specific pest (one with and one without exclusion cage), 1 card with *Ephestia* eggs will be exposed on the plant; 5 Plasticine preys will be pinned on a plant and 10 Plasticine preys on a Styrofoam plate will be exposed on the ground; 10 seeds of each of *Poa annua* and *Viola arvensis* on two different Styrofoam plates or petri dishes will be exposed on the ground with an exclusion cage for big predators; 5 *Calliphora* larvae will be pinned on a plant and 10 *Calliphora* larvae on a Styrofoam plate will be exposed on the ground with an exclusion cage for big predators.

General design: 4 crop fields or less if SNH types and control can be managed on different sides of the same field



2 fields with SNH type 1 bordering



2 fields without SNH bordering

Design in crop field:

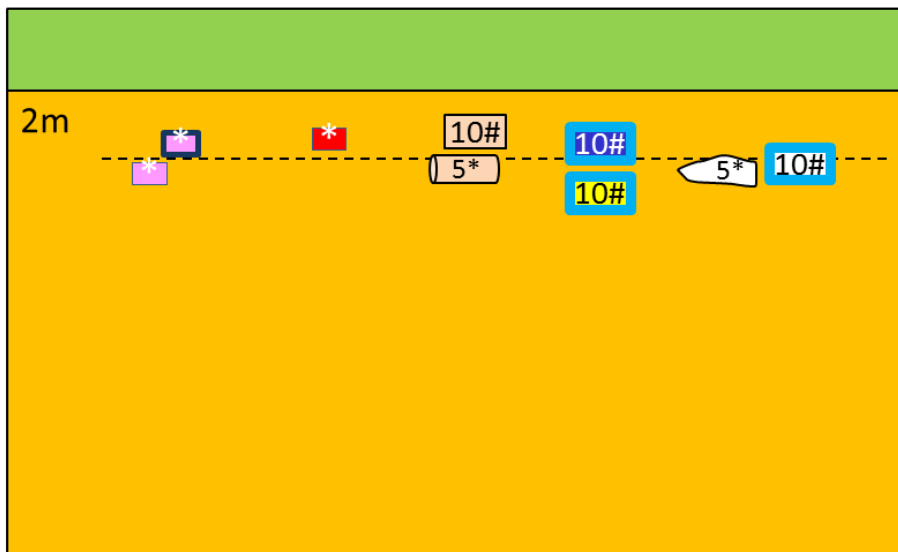

- Crop-specific pest
 - Living *Ephestia* egg mass
 - 10# Plasticine preys
 - 5* Plasticine preys
 - 10# Seeds of *Poa annua*
 - 10# Seeds of *Viola arvensis*
 - 10# Living *Calliphora* larvae
 - 5* Living *Calliphora* larvae preys
 - Exclusion cage adapted to the crop-specific pest
 - Exclusion cage for big predators – wire mesh
 - *
 - #
- * On the plant
On the ground

Philippe Jeanneret / Agroscope / Mai 2013

2.5 Results of testing techniques and implementation in 2014

Compiled by Ph. Jeanneret

Analysis was performed to evaluate the performance of parameters on the predation rates of sentinels exposed in fields. Parameters were:

- Duration of exposure,
- Exposure location – on plants versus on the ground,
- Presence or absence of semi-natural habitat at the margin of fields.

Models were evaluated by general linear mixed modeling techniques (GLMM) that included first all explanatory variables, and the principle of parsimony addressed then by removing non-improving interaction terms and explanatory variables (Zuur et al. 2012). Terms were evaluated with AIC and likelihood ratio. Analysis was used with the case study region as a random factor as well as an individual-level random effect to take into account the over-dispersion of the data, and a binomial error distribution. Standard model validation graphs were plotted to check homogeneity, normality and independence. Model specification and explanatory variables are detailed in sections below.

2.5.1 Ephestia egg cards

Cards with Ephestia eggs were exposed in fields firstly to assess the general level of parasitism that can occur. Unfortunately, measures to maintain eggs in good conditions were difficult to achieve and render the whole investigation too unsure. In addition, where investigated, parasitism of eggs seemed very difficult to recognize and to assess correctly. However, Ephestia eggs were eaten by predators. They will therefore be exposed in 2014 as to measure general predation (see section 3.3.2.2).

2.5.2 Plasticine baits

The aim of exposing of plasticine baits to predation was to test whether:

- Traces of predation could be observed on the baits
- Quantity of predation traces shows sensitivity to duration of exposition,
- Quantity of predation traces shows sensitivity to location, on plant vs on the ground,
- Quantity of predation traces shows sensitivity to the presence of adjacent SNH.

The factors location (plant vs ground), duration (various) were not standardized over all case studies on a balanced design basis (Table 3). Rather, various options were chosen in the different case studies.

Table 3: Number of plasticine measurements achieved in 2013. One measurement is a set of 3 to 20 plasticine baits depending on the case study, exposed on the ground and on the plant of the crop.

Number of measurements		Switzerland Oil seed rape		Germany Pumpkin		Estonia Oil seed rape		Hungary Wheat		The Netherlands Pear		Italy Olive	
Exposure	Duration	No SNH	SNH	No SNH	SNH	No SNH	SNH	No SNH	SNH	No SNH	SNH	No SNH	SNH
Ground	24h	8	8	8	16			1	1			12	12
Ground	30h									4	2		
Ground	48h	8	8			32	64	2	2	5	4		
Ground	72h			8	16								
Plant	24h			8	16							12	12
Plant	30h									4	2		

Plant	48h	8	8		32	64	2	2	5	4	
Plant	72h			8	16						



Figure 2: Plasticine bait (15mm long) with probable teeth marks of a rodent used to estimate predation rate in crops (Photo P. Jeanneret).

Exposure of plasticine baits showed contrasting results depending on the crop investigated across case studies. Indeed, the pumpkin case study in Germany revealed no traces of predation on plasticine baits while the pear orchard case study in The Netherland showed 100% of baits with predation traces.

The analysis including data from the case studies in Switzerland, Estonia, Hungary and Italy showed that there was no significant influence of the adjacent SNH to the quantity of traces observed on plasticine baits ($n = 298$, $\chi^2 = 0.11$, $P=0.74$). In contrast, the interaction effect of duration and exposure was significant ($\chi^2 = 4.14$, $P<0.05$) with no difference between exposure duration on the plants and more traces on plasticine exposed 24 hours on the ground (but large variability).

2.5.3 Calliphora larvae

The aim of exposing of Calliphora larvae to predation in the fields of the various case study regions was to test whether:

- the larvae would be eaten by generalist predators,
- predation rate shows sensitivity to duration of exposure,
- predation rate shows sensitivity to location, on plant vs on the ground,
- predation rate shows sensitivity to the presence of adjacent SNH.

The factors location (plant vs ground), duration (various), and with or without cage, were not standardized over all case studies on a balanced design basis (Table 4). Rather, various options were chosen in the different case studies to cover most of the sources of possible variability.

Table 4: Number of measurements achieved in 2013. One measurement is one plate with 10 or 20 Calliphora larvae, depending on the case study, exposed on the ground of the crop. On the plant, the number of individual Calliphora larvae varied between 3 and 10 per measurement.

Number of measurements			Switzerland Oil seed rape		Germany Pumpkin		Estonia Oil seed rape		Hungary Wheat		The Netherlands Pear		UK Wheat		Italy Olive	
Exposure	Duration	Cage	No SNH	SNH	No SNH	SNH	No SNH	SNH	No SNH	SNH	No SNH	SNH	No SNH	SNH	No SNH	SNH
Ground	24h	Cage	8	8	16	32							12	12	12	12
Ground	24h	No Cage			16	32			1	1					6	6
Ground	30h	Cage									2	2				
Ground	48h	Cage	8	8							4	4				
Ground	48h	No Cage					32	64	2	2						
Plant	24h	No Cage			16	32							12	12	12	12
Plant	30h	Cage									2	2				

Plant	48h	Cage					4	4		
Plant	48h	No Cage	8	8		32	64	2	2	

Model evaluation showed that adjacent SNH had no significant impact on the rate of predation of *Calliphora* larvae exposed in the crop ($n = 440$, $\chi^2 = 0.32$, $P=0.57$). In contrast, the interaction between the location (ground vs plant) and the duration (24h vs 48h) had significant influence on the number of prey removed ($\chi^2 = 93.10$, $P<0.001$) with a higher difference between 24 and 48 hours exposure on the ground than on the plants, and was included into the simplest model.

The conclusion of the analysis is that 48 hours of exposure is likely to hide any sensitivity to other factors because all larvae may be eaten as shown in the case studies of Switzerland and the Netherlands. Results showed a trend of increased predation of *Calliphora* larvae exposed 24h on the ground of fields with adjacent SNH (Figure 3b) and the effect was significant at $P<0.1$ level ($n = 122$, $\chi^2 = 3.12$, $P=0.07$).

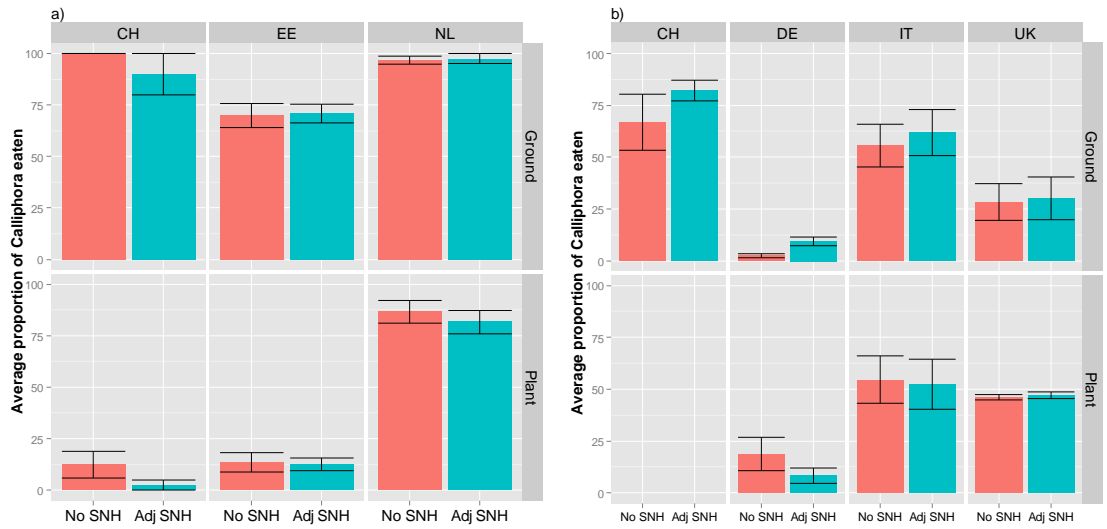

Figure 3: a) 48 hours exposure, b) 24 hours exposure.

Furthermore, specific layouts were tested:

- effect of the distance to the adjacent SNH and non-SNH on the predation rate (Germany),
- effect of a cage to protect against big predators (e.g. birds , foxes)(Germany and Italy).

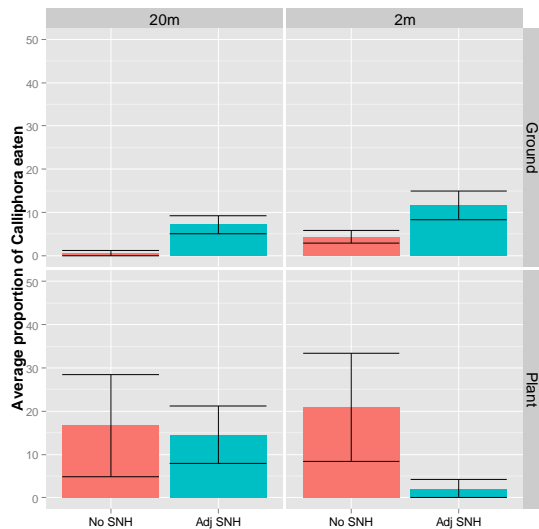

Figure 4: Average percentage of *Calliphora* larvae eaten in pumpkin fields (Germany) on plants and on the ground at 2 and 20 m distance from the border of the field with and without adjacent SNH (n = 72).

Model testing showed that 2nd-level interactions between the location (ground vs plant) and the adjacent habitat (SNH vs no SNH) and the distance to the margin (2m vs 20m) had significant impact on the rate of predation of *Calliphora* larvae exposed in the German pumpkin crops (n = 72). The distance to the margin alone had no impact neither on the rate of predation of *Calliphora* larvae exposed on plants (n = 24, $\chi^2 = 1.42$, P=0.23) nor on the ground (n = 48, $\chi^2 = 3.63$, P=0.06). In contrast, the presence of SNH significantly positively influenced the *Calliphora* exposed on the ground (n = 48, $\chi^2 = 7.68$, P<0.01) but not on the plant (n = 24, $\chi^2 = 1.94$, P=0.16).

The effect of cages set up on top of the *Calliphora* larvae exposed on the ground to protect against big predators was significant (tested in the case studies of Germany and Italy) on predation of the *Calliphora* preys (n = 84, $\chi^2 = 5.97$, P<0.05) with slightly more predation without the cage. Considering these two case studies, the presence of SNH at the margin significantly increased the proportion of *Calliphora* eaten (n = 84, $\chi^2 = 4.29$, P<0.05).

2.5.4 Other animal preys

2.5.4.1 Aphids in the case studies of UK, Switzerland and Germany

Aphids were exposed on plants in crops with adjacent and without adjacent SNH. The predation rate of aphid preys was not significantly explained by the presence of SNH in the vicinity of the crop (n = 136, $\chi^2 = 0.22$, P=0.63). Furthermore, particular factors were investigated in the German case study, namely the exposure duration, the presence of adjacent SNH and the distance to them. Aphids were exposed in fields of two pumpkin species. The predation rate of aphids was not significantly dependent on the presence either of SNH nor on the distance to them and nor on the pumpkin species (n = 96, $\chi^2 = 2.5$, 0.09 and 0.67, P=0.11, 0.77 and 0.41, respectively). In contrast, the duration of exposure was highly significant with 72 hours exposure close to 100% predation ($\chi^2 = 93.9$, P<0.001).

2.5.4.2 *Drosophila* (pupa) in the UK case study

In the UK case study, *Drosophila* pupae were exposed in wheat fields with and without adjacent SNH. The predation rate was significantly higher in fields with adjacent SNH (n = 12, $\chi^2 = 3.96$, P<0.05).

2.5.5 Seed predation

The aim of exposing of seeds baits to predation was to test whether:

- Predation could be observed on the seeds,
- Predation is different according to the plant species,
- Predation shows sensitivity to the presence of adjacent SNH.

Again, various sets of seeds were exposed to predation in fields of the case studies.

Table 5: Number of measurements achieved in 2013. One measurement is one plate with various numbers of seeds depending on the case study, exposed on the ground of the crop.

Number of measurements	Germany Pumpkin		Estonia Oil seed rape		Hungary Wheat		The Netherland s Pear		UK Wheat	
	No SNH	SNH	No SNH	SNH	No SNH	SNH	No SNH	SNH	No SNH	SNH
Seeds (plant species)										
Brassica nigra			32	64						
Centaurea jacea			32	64						
Chenopodium quinoa									12	12
Datura stramonium					2	2				
Echinochloa crus-galli					2	2				
Galium aparine					2	4				
Hibiscus trionum					2	2				
Lolium multiflorum									18	18
Papaver rhoeas					2	4				
Poa							6	6		
Poa pratensis			32	64					12	12
Seeds(Poa, Chenopodium, Stellaria, Atriplex)	32	64								
Setaria pumila					2	2				
Sinapis alba			32	64						
Stellaria media					2	4			12	12
Viola							6	6		
Viola arvensis									30	30
Viola wittrociana			32	64						

A first analysis was conducted with *Viola* spp. and *Poa* spp. as both have been exposed in three case studies. Model evaluation showed that neither adjacent SNH had significant impact on the predation rate of seeds exposed in the crop ($\chi^2 = 0.001$, $P=0.97$) nor any difference between the predation rate of the two plant species could be demonstrated ($\chi^2 = 1.43$, $P=0.23$). Furthermore, analysis was performed within case studies separately.

In the case study of Germany, an orthogonal sampling design allowed to test duration (24 vs 72 hours), distance (2 vs 20 m), the presence of cage and SNH at the margin of the field, on the predation rate of various seeds exposed together (no possible distinction between species). However, 24 hours exposure was too short to reasonably measure predation. So, data of 72 hours exposure were further analyzed then. With this subset of data, the distance x adjacent SNH interaction was significant (individual-level random effect only, the field as random did not significantly improve the model) ($n= 48$, $\chi^2 = 5.54$, $P<0.05$). Then at 2 m distance from the field margin, the rate of seed predation was not dependent on

adjacent SNH ($n=24$, $\chi^2 = 0.19$, $P=0.66$). In contrast, at 20 m from the margin, the predation rate of seeds was higher in fields without adjacent SNH ($n=24$, $\chi^2 = 6.46$, $P<0.05$).

In the case study of Estonia, seeds of 5 different plant species were tested in oilseed rape fields. There was no significant influence of adjacent SNH on the predation rates of the seeds ($n=480$, $\chi^2 < 0.001$, $P=0.99$) while the predation rate was largely dependent on the plant species ($n=480$, $\chi^2 = 31.63$, $P<0.001$) with highest predation rates for *Viola spp.* and *Centaurea jacea*.

In the case study of Hungary, seeds of 7 different plant species were exposed to predation in wheat fields. The rate of seed predation was not dependent on adjacent SNH ($n=34$, $\chi^2 = 1.44$, $P=0.23$). In contrast, the type of seeds exposed were differently eaten ($\chi^2 = 58.13$, $P<0.001$) with highest rates of predation for *Papaver rhoeas* and *Echinochloa crus-galli* while the exposure technique, i.e. on seed cards or in petri dishes, had also a significant influence on the predation rate of the seeds ($\chi^2 = 24.55$, $P<0.001$) with more seeds eaten in petri dishes.

In the case study of the UK, 3 different formats for the exposure were tested: clay dishes, stick cards and sand paper, with seeds of 5 different plant species. The rate of seed predation was not depending on adjacent SNH ($n=143$, $\chi^2 = 0.63$, $P=0.43$), and no significant effect of the technique could be demonstrated ($\chi^2 = 0.05$, $P=0.82$). In contrast, the predation rate was significantly different from one plant species to the other ($\chi^2 = 15.52$, $P<0.005$) with highest predation rates for *Poa pratensis* and *Lolium multiflorum*.

In the case study of the Netherlands, beside the presence of SNH adjacent to pear orchards or not, the duration of exposure to predation of *Viola spp.* and *Poa spp.* seeds was tested. The interaction between the plant species and the presence of SNH was significant ($n=24$, $\chi^2 = -7.33$, $P<0.05$) with a clear higher predation rate for the *Viola spp.* seeds in orchards with adjacent SNH.

In the case study of France seeds of three species were exposed to predation, namely *Chenopodium alba*, *Trifolium repens* and *Vicia villosa*, in vines and forest during 7 and 14 days. There were significant interaction effect on the predation rate of the seeds between the plant species and the location (forest vs vines) with less predation of *T. repens* and *V. villosa* in vines ($n=425$, $\chi^2 = 8.9$, $P<0.05$). Furthermore, the interaction location x duration has also a significant impact on the predation rate, namely in forest, almost all seeds were removed after 7 days already but not in vines ($n=425$, $\chi^2 = 10.9$, $P<0.001$).

2.5.6 Conclusion of test 2013 and decisions for 2014-2015

Ephestia eggs are discarded for the measurement of parasitism in fields due to the practical problem of maintaining eggs in sufficient good conditions, and difficulty to observe parasitism. Exposure of *Ephestia* eggs was still used in 2014 to measure the general predation. They were exposed on plants glued on a piece of paper, and on a paper card on the ground, both for 24 hours. Exposure was repeated twice during the season.

Exposure of plasticine baits was promising for practical reasons but was not convincing because of a too low level of predation traces found by testing, and was therefore discarded in 2014.

Calliphora larvae slightly showed more predation exposed on the ground of fields in situation where adjacent SNH where occurring (effect over all case studies and specifically in Germany). They were kept

for 2014 measurements with adaption of a 24 h exposure on the ground on Styrofoam plates or plastazote (10 larvae) and protection against big predators. Their use as baits exposed on plants is rejected. Exposure is repeated two times during the season.

Aphids and *Drosophila* were not tested as preys in sufficient case studies to implement them everywhere on a standard basis. So, both were left to QuESSA partners to make decision on their use or not.

Seeds of various plant species were tested in different countries and showed contrasting results. The 2014 survey consists of exposing seeds of *Poa trivialis* and *Chenopodium album* on white dry stick cards covered with sand for 7 days, twice during the season.

3 Ecosystem service assessment in 2014

3.1 Introduction

To quantify actual delivery of ecosystem services provided by semi-natural habitats (SNH) and particular field management for major European cropping systems across four agro-climatic zones, a series of methods will be used in 2014 and 2015 in the QuESSA case studies.

Methods include:

- The use of invertebrate and seed sentinels to assess general predation and parasitism,
- The assessment of the crop specific pest density,
- The assessment of predation and parasitism of crop specific pests,
- The assessment of pollination rate,
- The assessment of ecosystem service providers (natural enemies and pollinators).

A series of protocols for assessment of ecosystem services in CS was established considering project hypotheses and resulting in a full sampling design that will allow overarching analysis of data collected in CS. Methods will be applied in focal fields and SNH in landscape sectors, displayed in a general design to achieve the best possible standardization.

3.2 Selection of focal fields and SNH in landscape sectors

3.2.1 Hypotheses, explanatory variables and general design

The design should allow proper statistical analysis and be standardized as far as possible to allow overarching analysis of data over all case studies because this is the added value of such a project. Every case study should try to adapt to fit as much as possible strictly adhere to the common design.

In QuESSA, we aim at testing the hypotheses that ecosystem services in focal fields depend on:

- The type of SNH at the margin of the focal field, basically, 2 types (1 woody SNH and 1 grassy SNH) and a control (categorical variable);
- The proportion of SNH in a landscape sector of 1 km radius around focal fields following a gradient (continuous variable);

- The management intensity of the focal field, organic vs non-organic (categorical variable) or a gradient of intensity (continuous variable).
- ➔ Three explanatory variables and four possible interactions.

The design will establish the number of landscape sectors, focal fields and SNH as well as their characteristics for measurements in 2014 and 2015.

3.2.2 General rules

- 1) Each region will select (at least) **18 focal fields** – the case study specific crop – **in the middle of landscape sectors of 1 km radius.**

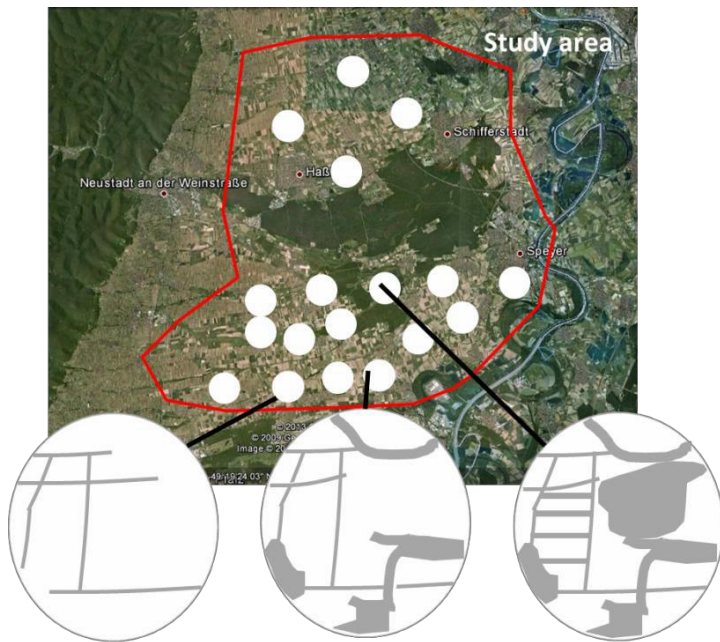

Landscape sectors (N=18) from simple to complex

Figure 5: Example for the selection of 18 landscape sectors around focal fields in a study area along a gradient of landscape complexity, i.e. increasing coverage of SNH (grey).

- 2) Simple and complex landscape sectors should be spatially interspersed, i.e. **neighbouring landscape sectors should be as different as possible in terms of landscape complexity**. Similarly, **focal fields in neighboring landscape sectors should have different bordering SNH**. In other words, complex landscape sectors **should not all be grouped** in a corner of the region under study (e.g. at high altitude), and simple landscape sectors in another corner (e.g. at low altitude). Similarly, all focal fields with grassy SNH **should not all be grouped** in a corner of the region, and focal fields with woody SNH in another corner. The reason for this is that landscape complexity and SNH type must be independent of spatial position to avoid possible (spatially structured) factors to confound the effect.
- 3) Focal fields in complex and simple landscape sectors should be as similar as possible with respect to all local conditions (field size, soil type, slope, altitude, etc.).

- 4) Landscape sectors should not overlap (at least not more than 20%). However, the landscape sectors for 2014 and 2015 sampling, and the 2013 sectors may overlap. So: no overlap in SPACE, but there may be overlap in TIME.

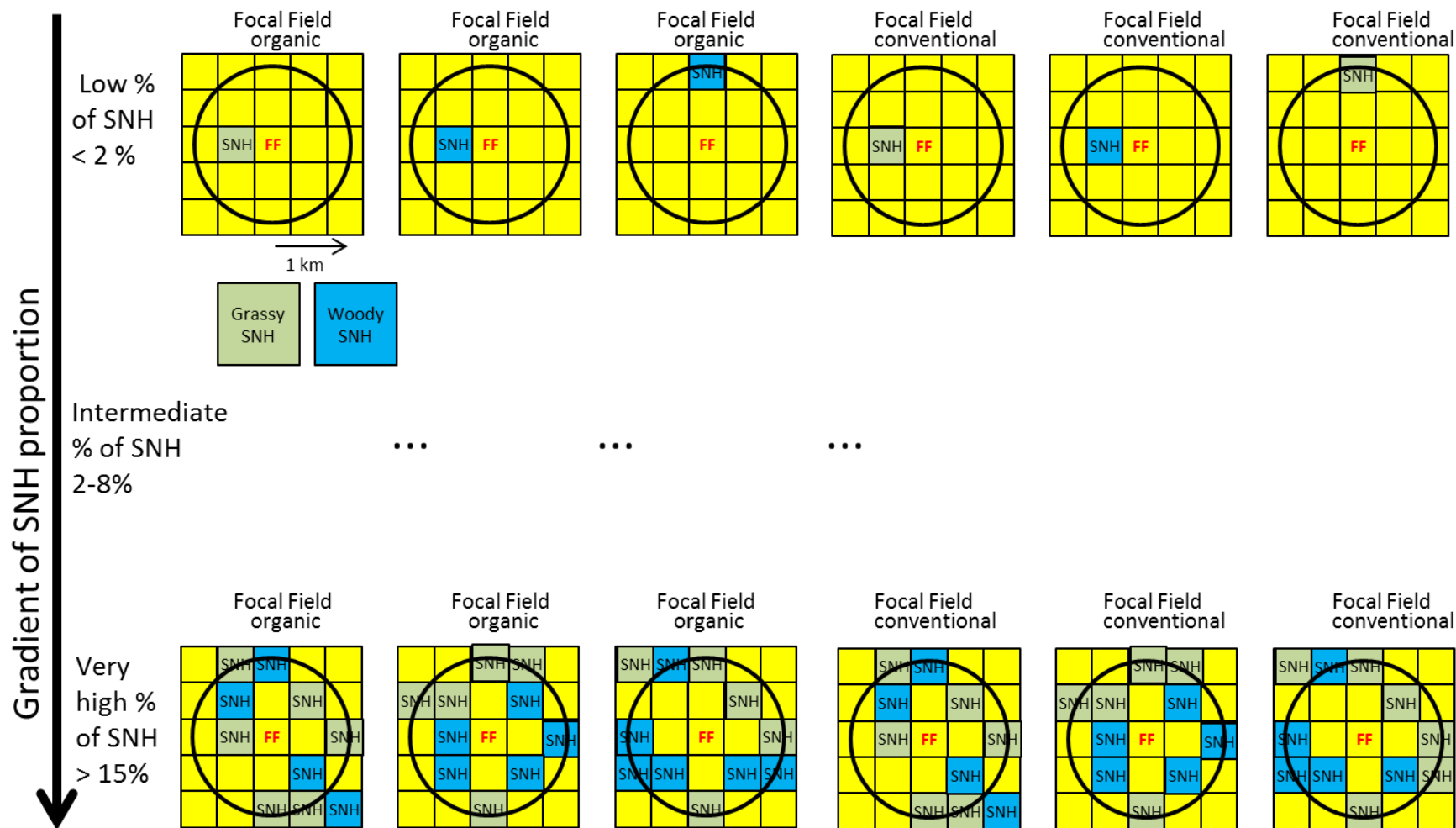

Figure 6: General sampling design for focal fields and SNH in QuESSA 2014-2015. Focal fields have to be selected in landscape sectors with gradual increase of SNH proportion in the 1km radius sector. Within one class of SNH proportion (classes should help selecting landscape sectors: low, intermediate and very high), 6 focal fields will be selected with specific focus sides, i.e. 2 with a grassy SNH bordering (1 organic, 1 non-organic), 2 with a woody SNH bordering (1 organic, 1 non-organic) and 2 without SNH bordering (1 organic, 1 non-organic). The total number of fields and landscape sectors is 18.

3.2.3 Type of SNH at the margin of the focal field

- 1) **Each focal field will be bordered on one of its sides – the focus side – directly adjacent, by either a grassy SNH or a woody SNH or no SNH** (if fields without any bordering SNH are not available, fields have to be selected with as narrow as possible a simple grassy margin).
- 2) **The bordering SNH can either be linear or areal:**
 - a. SNH Linear Elements (WL, HL) should have a minimum width of 1.5m and a maximum width of <25m. They must be at least 50m in length.
 - b. SNH Areal Elements (WA, HA, FA) should be at least 25m wide and at least 50m in length.
- 3) Within one class of SNH proportion (classes are just to help) in the landscape sectors (low, intermediate and very high, see Figure 6), **six focal fields will be selected**, i.e. two with a grassy SNH bordering (1 organic, 1 non-organic – if being compared), two with a woody SNH bordering (1 organic, 1 non-organic) and two without SNH bordering (1 organic, 1 non-organic).

3.2.4 Traits record in SNH at the margin of the focal field

Basically, bordering SNH should be as typical as possible compared to the SNH assessed for the WP2 typology in 2013. Nevertheless, assessing traits of bordering SNH while measuring ecosystem services in focal fields, offers a more direct analysis of the effect of the traits than considering the “average” traits measured in 2013 or the score derived. It is then recommended to record at least basic traits as for WP2, **see the form at the end of this protocol**. Vegetation surveys (vegetation plots) as for WP2 are optional but would also greatly contribute to a better understanding of results regarding ecosystem services measurements in focal fields.

1. **LARGER SCALE:** The measures of vegetation and functional traits of the **woody vegetation part** (shrubs and trees), some functional traits of the herbaceous layer that cannot be assessed properly at the smaller plots (1 x 5 m), as well as the adjacent land uses will be measured more roughly in a **transect walk of 50 x 1.5 m** (2 consecutive pollination transects: the internal ones, if possible).
2. **FINER SCALE:** The attributes of the herbaceous layer (most of its functional traits, spp. composition, etc.) will be measured more precisely in the four **5 x 1 m plots** (vegetation plots).

What should be measured at the LARGER SCALE?

Functional traits in a transect of 50 x 1.5 m = 75 m² (adapted from WP2 protocol):

- I. Spatial structure of the SNH:
 - a. If it is LINEAR: Width of the different elements (m).
 - b. If it is AREAL: Surface of the entire element (assessed from maps). This surface will refer to entire SNH area and not only to the portion of the SNH that is inside the landscape sector of 1 km radius.
- II. Description and functional information of the vegetation layers herb layer (0-1m); shrub layer (1-4m); tree layer (>4m):

- a. For the WOODY VEGETATION PART (shrubs and trees that have entire or part of the trunk inside the 50x1.5m plot):
 - flower abundance at delivery time of ES.
 - Number of standing dead trees.
 - Tree canopy cover: average percentage cover in terms of canopy projection on the ground (100% - % visible sky).
 - Mean height of tree canopy to be estimated from the exterior (see appendix 1 Deliverable 2.2).
 - Description of visual management signs.
 - Number of dead wood shrubs.
 - Shrub cover: average percentage cover in terms of canopy projection on the ground. Max is 100% and can be estimated as (100% - % visible sky).
 - Mean height of shrub canopy to be estimated from exterior (see appendix 1).
 - Description of visual management signs, included if trees were a plantation (neat rows of trees).
- b. For the HERBACEOUS VEGETATION PART (understory features):
 - flower abundance at delivery time of ES.
 - Number of lying dead wood
 - Number of bee hives.

What should be sampled at the **FINER SCALE**? (small plots (5 x 1 m))

- Herbaceous cover: average percentage cover.
- Bare soil cover: average percentage cover.
- Litter cover: average percentage cover.
- Description of visual management signs.
- Functional information:
 - Mean height of herbaceous canopy measured using the “direct measurement method” explained in and evaluated by Stewart et al. (2001):
(i) The ‘direct measurement method’ involves placing a card or hand lightly on the vegetation at the level below which about 80% of the vegetation is estimated by eye to be growing (thus ignoring occasional tall stalks), then reading this height on a ruler
 - Dead herbs (%) seen from above
 - Tussocky grass cover (%) seen from above
 - Fine grass cover (%) seen from above
 - Broad-leaved cover (%) seen from above

- Phenological stage of case study crop in simple 5 step classification (1: germinating plant, 2: shooting plant, 3: flowering, 4: seed ripening, 5: dry plant).
- Full vegetation records are abandoned.

3.2.5 The management intensity of the focal field

Focal fields should be selected according to a management intensity gradient, best containing organic and non-organic fields, i.e. three organic and three non-organic fields, each bordered either by a grassy SNH or a woody SNH or no SNH, per class of SNH proportion in the landscape sectors (see Figure 6). If organic vs non-organic fields are not available, then fields should be selected that cross-combine both management intensity levels, and grassy or woody bordering SNH (not all focal fields with woody SNH and at the same time intensively managed). If no differences of management intensity can be found in the region, three focal fields per adjacent SNH type and per class of SNH proportion should still be selected, i.e. 18 focal fields in any case. If all fields are +/- managed the same, outliers such as fields without pesticide use, etc. should be avoided.

3.2.6 Proportion of SNH around focal fields and mapping of the landscape sectors

Debra Bailey, Felix Herzog and Philippe Jeanneret

Landscape sectors will be selected **along a gradient of landscape complexity and must contain a focal field in their center, i.e. the case study specific crop.**

The gradient should cover a broad range of landscapes and must include both extremes, i.e. very simple landscapes with a low proportion of SNH and the most complex found within the typical arable production area with a high proportion of SNH (see example Figure 5). How to consider woodland for estimating the proportion of SNH? : to fit to the definition of WP2 for SNH, the whole woodland area should be considered SNH and not only the edge (but effects are probably mostly due to the first 20 m). However, pure commercial conifer forests cannot be considered SNH. Consequently, the whole woodland area can be considered for the selection of the landscape sectors along the complexity gradient but if commercial conifer forests are occurring, then rather a rough estimate of their edge (buffered 20 m) should contribute to the estimation of the proportion. Exact determination of the proportion SNH can take place after digitalization of the landscape sectors. Proportion of SNH will depend on CS. The idea is to have a gradient (classes are just to help). Different SNH types have different areas; percentages can differ accordingly. For each SNH type, the landscape gradient should cover a >10-fold increase. E.g. woodland 2-50%, hedgerow 0.1-2%.

3.2.6.1 Aims and needs of mapping landscape sectors

In order to test these hypotheses we need to produce maps of our landscape sectors. The maps will enable us to assess the area and proportion of SNH, crops, etc. The areas (and distances from Focal Field (FF) to SNH) can then be used as a weighting factor for the SNH scores (or individual features).

The maps are also essential for WP4. Thus, the needs of WP4 are accounted for in the current protocol, e.g., detailed categorisation of crop types in the sector.

From the map product it will be possible to measure the area, length, spatial configuration and percentages of the habitats that we have recorded on our maps.

In WP 3 our aims are to test the hypotheses that ecosystem services (ES) and service providers depend on the amount and proportion of semi-natural habitats (SNH), crops, etc. of diverse types (SNH types and scores, crop management, etc.).

3.2.6.2 Approach

We propose a minimum standard of mapping that all partners should achieve. In addition, partners can add information to their maps, e.g. recording solitary trees, if this data is considered relevant to their case study.

The minimum standard is *to produce a map without gaps*, i.e. a complete map of the landscape sector rather than one with 'holes'. This means that we will map certain habitat types (SNH, urban areas, water courses and crops etc.) and classify the rest of the sector as non-habitat. All elements will be mapped as polygons. The map of the landscape sector will include the following habitats as standard:

1. Focal Field
2. 5 SNH types (Woody Areal (WA), Woody Linear (WL), Herbaceous Areal (HA), Herbaceous Linear (HL), Temporary in-field SNH (FA))
3. Crops
4. Urban areas
5. Water courses
6. Remaining gaps in the sector will be classified as non-habitat (e.g. roads, lakes, etc.)

3.2.6.3 Habitat Definitions

The SNH types are the same as for WP2 and will be recorded throughout the landscape sector. Table 1 lists the codes to be attributed to the SNH and all other recorded habitats in the attribute table associated with the maps of the landscape sectors. The SNH types are defined as follows:

1. WA: natural or semi-natural woody areal elements: including abandoned fields with more than 30% shrub/tree canopy cover*. The additional quality of estimated height of the element (at the edge being observed) will be recorded during mapping (see section 9)
2. WL: woody linear elements: any type of linear structure with more than 30% tree/shrub canopy cover*. The additional quality of estimated height of the element (at the edge being observed) will be recorded during mapping (see section 9)
3. HA: herbaceous areal elements: fields abandoned which have not developed more than 30% shrub/tree canopy cover*, *including semi-natural grasslands*. Herbaceous areal vegetation can also be sown (flower or grass mixtures). Grasslands to be included in this category should have a value to nature, be permanent and low-input. As such the classification of grassland will be case

study specific. To allow for standardisation at the European level and to aid in the decision as to whether the grasslands in the sector are semi-natural, partners are requested to refer to the documents located on huddle (Huddle: QUESSA\WP4\EU grasslands book). The management of the grassland is to be noted on the recording sheet during mapping (see section 9)

4. HL: herbaceous linear elements: any type of linear element with less than 30% tree/shrub cover* and herbaceous strip. Herbaceous vegetation can also be sown (flower or grass mixtures). Water courses may be included.
5. FA: Temporary in-field SNH: fallow, cover crops, not-marketable intercrops.

* Canopy cover measured as ground projection of the closed canopy layer

If other SNH in a region are common which do not fit these categories, further categories may be added. These categories will then be case study specific. SNH categories added by the partner should follow the code format of Table 1, i.e. a new category would be added as 1.'x'.

The crops in the landscape sector will be recorded as follows:

1. All crops/crop categories in the landscape sector will be recorded. The codes to be used for the crops are detailed in Table 1. If other crops common to the region are not included in the table, further crops and codes may be added.
2. Fields recently ploughed or fallow are to be recorded as cultivated bare ground (<30 vegetation cover), see Table 1.
3. Crop land management is not always synchronic with maximum biomass. Therefore if the crop has been harvested within the last month, but evidence of the actual crop is present, then it should be recorded as such.
4. Rotational grasslands are to be classified as a crop. *The rotational grasslands < 5 years old and > 5 years old* will be recorded as different crops (Table 1). Interrupted grasslands (grasslands ploughed every 3-4 years and then sown with the same grass species) have also been allocated a separate crop category in Table 1.

Depending on the case study it may be necessary to map certain crops in more detail than the suggested categories throughout the landscape sector. It is up to the individual partners to decide what their special requirements are for their individual case studies. These further categories will be treated as case study specific. Any crops added by the partner should follow the code format of Table 1 for the crop categories, i.e. a new crop would be placed within 2.'x', 3. 'x' and 4.'x'.

The **urban areas** will be recorded throughout the sector. It is suggested that the urban areas are not mapped in the field but taken from digital topographical maps if available. It is also possible to digitise the urban areas from aerial photographs. The urban areas are to be classified into 4 categories according to the amount of 'green area' within the element (see Table 1). This assessment (a rough estimation) can be undertaken prior or after field mapping using aerial photographs. For some case study regions a further categorisation of the urban areas may be necessary, e.g. identification of glasshouses. Further categories added by the partners will be treated as case study specific. . Any urban categories added by the partner should follow the code format of Table 1 for urban elements, i.e. 5.'x'.

The **water courses > 1.5m wide (e.g. rivers, streams, canals, drainage ditches)** are to be recorded throughout the landscape sector. This information can be selected from the topographical maps. These elements may be represented as line elements in the topographical maps. It will be necessary in such cases to buffer these elements to provide a width *using the average width* recorded for the element during mapping.

All other habitats that DO NOT fall into the SNH, crop, urban or waterways defined above will be classified as non-habitat. These habitats include roads and lakes. If any of these habitats are relevant to case study partner they may of course be mapped.

Table 1: Habitat codes for the map attribute table

HABITAT	Code
Semi-natural habitat (SNH)	
WA: natural or semi-natural woody areal elements	1.01
WL: woody linear elements	1.02
HA: herbaceous areal elements	1.03
HL: herbaceous linear elements	1.04
FA: Temporary in-field SNH	1.05
Crops¹	
Annual herbaceous Crops	
Cultivated Bare Ground	2.01
Wheat (<i>Triticum aestivum</i> & associated sp)	2.02
Barley (<i>Hordeum sativum</i>)	2.03
Oats (<i>Avena sativa</i>)	2.04
Rye (<i>Secale cereale</i>)	2.05
Triticale (hybrids between wheat & rye)	2.06
Rice (<i>Oryza sativa</i>)	2.07
Sugar beet (<i>Beta oleracea</i>)	2.08
Fodder crops (e.g. <i>Brassica oleracea</i>)	2.09
Potato (<i>Solanum tuberosum</i>)	2.10
Field beans (<i>Vicia faba</i>)	2.11
Peas (all types) (<i>Pisum spp</i>)	2.12
Maize (<i>Zea mays</i>)	2.13
Oilseed rape (<i>Brassica hybrid</i>)	2.14

Sunflower (<i>Helianthus annuus</i>)	2.15
Pumpkin (all types) (e.g. <i>Cucurbita</i> spp)	2.16
Flowers	2.17
Commercial horticulture	2.18
Vines	2.19
Cover crop	2.20
Forage crop	2.21
<i>Medicago sativa</i> ²	2.22
Rotational grassland < 5 years old	2.23
Interrupted grassland	2.24
Perennial herbaceous crops	
Asparagus (<i>Asparagus</i> sp)	3.01
Rotational grassland >5 years old	3.02
Permanent grassland (NOT SNH)	3.03
Perennial woody crops	
Vines (<i>Vitis vinifera</i>)	4.01
Olives (<i>Olea europea</i>)	4.02
Cherries (<i>Prunus</i> spp.)	4.03
Apples (<i>Malus</i> spp.)	4.04
Pears (<i>Pyrus</i> spp.)	4.05
Walnuts (<i>Juglans</i> spp.)	4.06
Citrus fruit (<i>Citrus</i> spp.)	4.07
Hazelnuts (<i>Corylus avellana</i>)	4.08
Almonds (<i>Prunus amygdalus</i>)	4.09
Prickly pear (<i>Opuntia</i> spp.)	4.10
Pistacio nuts (<i>Pistacia sativa</i>)	4.11
Apricots (<i>Prunus amygdalus</i>)	4.12
Peaches/Nectarines (<i>Prunus persica</i>)	4.13
Urban areas	
Urban area, % of green area in element <25%	5.01
Urban area, % of green area in element 26 to 50%	5.02
Urban area, % of green area in element 51 to 75%	5.03
Urban area, % of green area in element >75%	5.04
Water courses	
(e.g. rivers, streams, canals, ditches >1.5m wide)	6.0
Non-Habitat	
(e.g. roads, lakes)	7.0

¹Depending on the case study partners may wish to map certain crops in more detail throughout the landscape sector. It is up to the individual partners to decide upon special requirements for their individual case studies. Further categories may be treated as case study specific.

²Please note *Medicago sativa* is listed here as a separate category. This is because it may be necessary to identify this crop in further analyses or to reclassify it as an HA habitat.

3.2.6.4 *Size of the landscape sector and the minimum mapping size (Spatial resolution and spatial extent)*

The size of the landscape sector is to be defined as a 1km² radius. This is to be set from the *centre of the ecosystem services transect* undertaken in the FF.

The **minimum mapping unit (MMU) definitions** are as follows:

- Any element (SNH, crop, urban area, water course) selected for mapping in the landscape sector needs to have a **minimum surface area of 75m²**, in order to guarantee a minimum impact on beneficial and therefore on ES delivery.
- **SNH Linear Elements** (WL, HL) should have a **minimum width of 1.5m** and a **maximum width of <25m**. They must be **at least 50m in length**.
- **SNH Areal Elements** (WA, HA, FA) should be **at least 25m wide and at least 50m in length**.
- **The remaining elements** (crops, water courses, urban areas) must be a **minimum width of 1.5m and at least 50m in length**.

3.2.6.5 *GIS and Geo-referencing system*

The LAEA coordinate system (see details below) is to be used for the **Geo-referencing** of the maps. A standardised geo-referencing system is especially relevant for WP4. For digitising purposes partners may if they wish use the system typical for the country/region of the case study. This may be especially relevant if other available digital data (aerial photographs, topographical maps) are projected in this system. *It is recommended to use the LAEA geo-referencing system from the beginning rather than converting the data at a later stage.* It is the responsibility of the partners to convert their maps to the LAEA system before data transfer if they chose to use another system beforehand.

The details of the geo-referencing system are as follows:

Coordinate System:

Lambert_Azimuthal_Equal_Area

False_Easting: 4321000,000000

False_Northing: 3210000,000000

Central_Meridian: 10,000000

Latitude_Of_Origin: 52,000000

GCS_ETRS_1989

Datum: D_ETRS_1989

Prime Meridian: 0

PROJCS

```
["ETRS_1989_LAEA",
GEOGCS ["GCS_ETRS_1989",
    DATUM ["D_ETRS_1989",
        SPHEROID ["GRS_1980",6378137.0,298.257222101]],
    PRIMEM["Greenwich",0.0],
    UNIT["Degree",0.0174532925199433]],
PROJECTION["Lambert_Azimuthal_Equal_Area"],
PARAMETER["False_Easting",4321000.0],
PARAMETER["False_Northing",3210000.0],
PARAMETER["Central_Meridian",10.0],
PARAMETER["Latitude_Of_Origin",52.0],
UNIT["Meter",1.0]]
```

The **GIS system** used for digitisation will depend on the availability of the program to the case study partner.

3.2.6.6 Elements in maps

All elements within the landscape sector are to be digitised as **polygons**.

It may be necessary for some partners to digitise point elements. For example, some partners may be particularly interested in the distribution of solitary trees within their landscape sector and may need to map and digitise these elements. Point elements are beyond the minimum standard of mapping that is required but may be added to the maps if required.

3.2.6.7 Metadata

Please attach the minimum metadata to each map:

- Projection system
- GIS system used for digitisation
- Source of aerial photographs or satellite images
- Source of base maps (top
- Additional codes added by the partners. For example, the additional SNH, crop, urban and water course codes that you added, management codes that you added etc.

3.2.6.8 Data Transfer

For data transfer purposes the GIS data of EACH individual landscape sector should be exported as a shape file.

3.2.6.9 The mapping procedure

The suggested mapping procedure (Figure 1) for each landscape sector is as follows:

1. Define your landscape sector. (Figure 2)
2. Use digital base maps (topographic and/or cadastral) to select available SNH, urban areas, water courses and permanent crops in your landscape sector. (Figure 3). This step can save mapping time in the field but it entirely up to the partner as to whether they undertake this procedure.
3. Assess urban areas for the percentage of 'green area' within the individual urban elements (see Table 1 for codes). This step may be undertaken before mapping or during the attribution phase of the maps described in step 6 below.
4. Prepare the aerial photographs ready for the field mapping.
5. Undertake the field mapping.
6. Digitise and attribute your maps in GIS, attach metadata
7. Validate your data, e.g. topology of maps, codes in attribute table.

Figure 1: Mapping Procedure

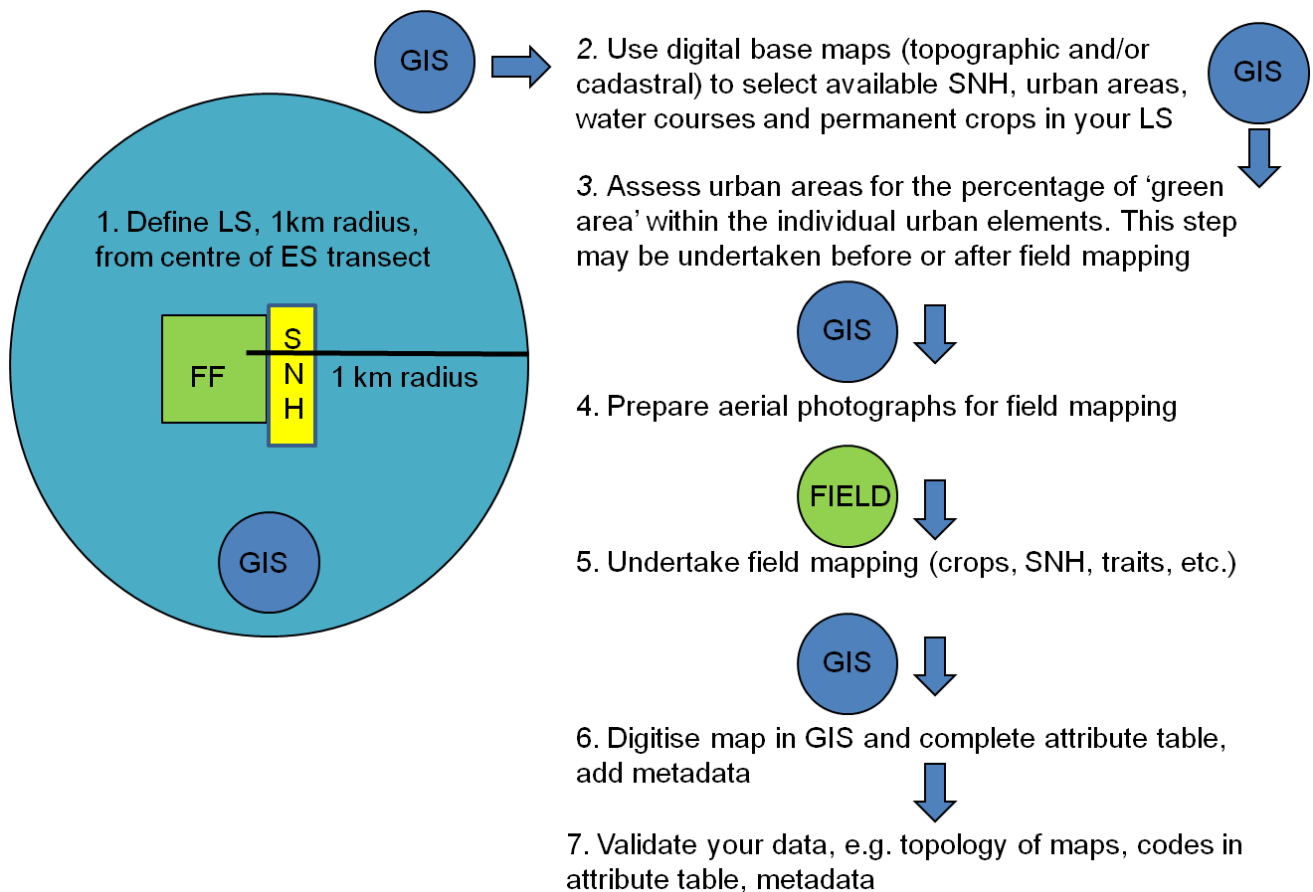

Please note:

1. The decision as to whether to undertake step 2 in Figure 1 above is left to the individual partners. It is possible to map all habitats directly in the field without undertaking this step. *It is recommended to utilise the digital topographical maps if they are available.*
2. Step 3 may be undertaken before field mapping or during the attribution phase of the maps after fieldwork.

Figure 2: Step1, defining your landscape sector (Step 1 of Figure 1)

1. Identify the location of your sampling transect for measuring ES
2. Digitise a point at the middle of this transect
3. Buffer 1km² radius from the digitised point to define the area of the LS

Legend

-  Landscape_Sector
-  Focal_Fields_FF
-  Transect



1:10'000

Figure 3: Step 2, using digital base maps (topographic and/or cadastral) to select certain SNH, water courses, urban areas and crop elements (*It is strongly recommended to utilise base maps if available. It is up to the individual partners as to whether they decide to undertake this step as all elements can also be mapped in the field*)

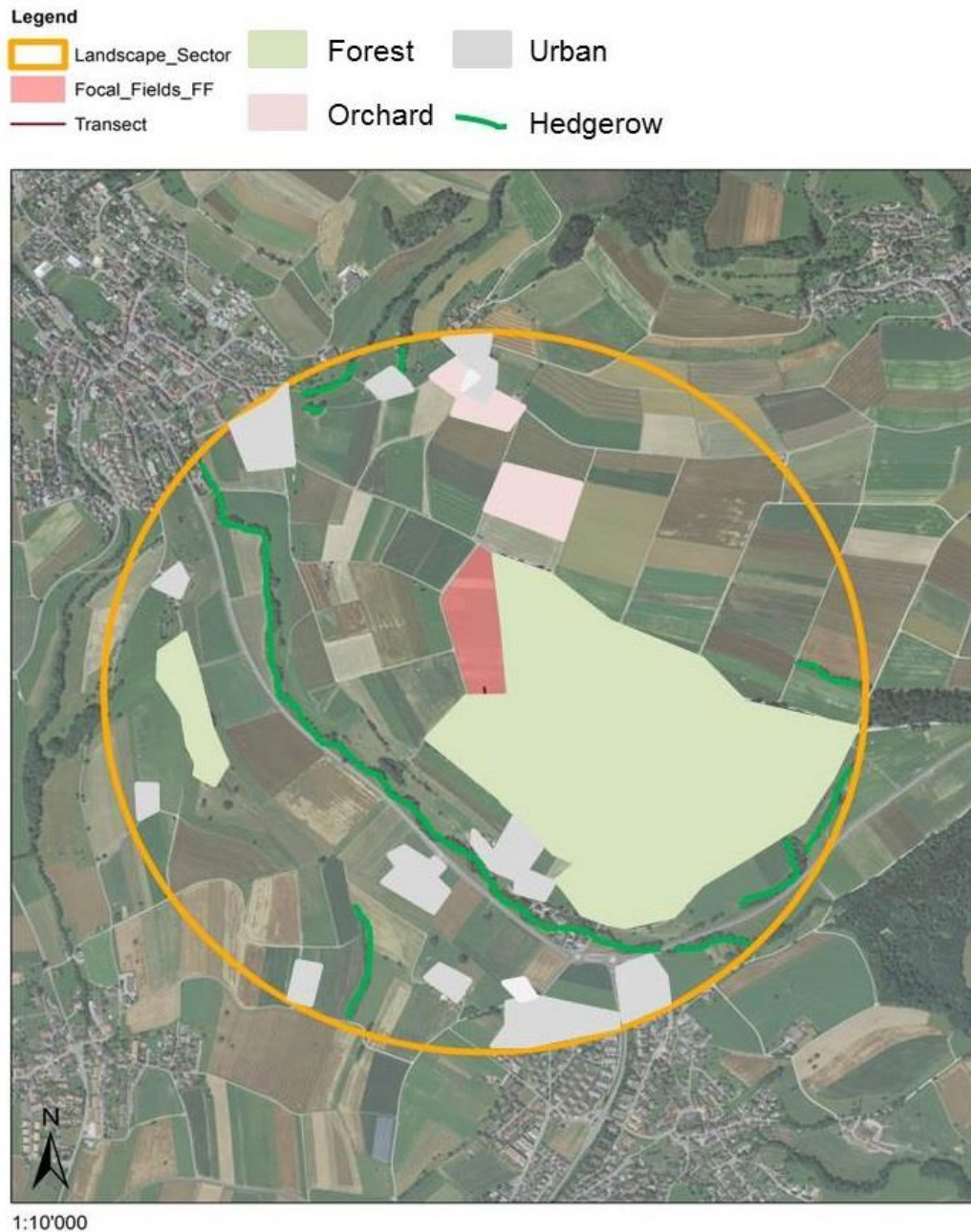

1. Preparatory work on the delineation of major elements within the landscape sector from aerial photographs, maps and/or satellite images is strongly recommended. The following sources are recommended from the European project EBONE (Bunce et al., 2010, available on Huddle, QUESSA\WP3\7 – Habitat mapping):
 - a. The most recent 1:10,000 scale (or at least 1: 25, 000 scale if of sufficient quality) base map including topographic and/or cadastral information is suitable, enlarged to 1:5,000 scale.
 - b. Aerial photography (AP) prints at the scale of 1: 5, 000. Aerial photographs should preferably be ortho-photos or else geometrical properties need to be assessed.
 - c. Digital outlines of the AP interpretation held on a field computer and the information in the field recorded directly.
 - d. Maps derived from satellite imagery. Image segmentation offers a further option for preparation before going into the field.
2. If a base map (topographic and/or cadastral) is available you can select the digitally available SNH, water courses, urban areas and crop elements within your landscape sector. Some of these elements will be available as polygons and others as line elements.
3. Linear elements that are available from base maps (e.g. potentially hedgerows, small water courses) will need buffering to produce polygon elements during digitisation. The width of the buffers can be added after noting the width of these elements during field mapping. Roads could also be selected from the digital maps and buffered according to the widths already defined in the base maps. In this case, the delineation of roads in the landscape sector can be undertaken as part of the field preparation. Roads are to be classified as non-habitat in the attribute table (see Table 1).
4. Urban areas, if possible, are to be selected from the base maps. During attribution of the maps the amount of 'green area' will need to be estimated from aerial photographs for each of the urban elements (see Table 1).
5. The digital SNH elements that are likely to be available for your sector are WA elements, e.g. forest, shrub. Linear elements such as hedgerows may also be available digitally.
6. The digital crop elements that may be available are likely to be vineyards, olive groves and high-stem orchards.

Step 3: Assess urban areas for percentage of 'green area' within the elements.

The urban areas are to be classified into 4 categories according to the amount of 'green area' within the element (see Table 1). This assessment (a rough estimation) can be undertaken prior or after field mapping using aerial photographs.

Step 4: Field Mapping Preparation

1. Underlay the aerial photographs for the sector with the data prepared in steps one and two of Figure 1.
2. This step is undertaken in preparation of the field mapping.
3. The aim is to produce a 'working map' that can be used to map the remaining elements in the field.
4. The form of the 'working map' is up to the individual partners. *It is recommended by Bunce et al. (2010) that the aerial photograph and prepared data should be enlarged to a scale of 1: 5,000.* In any case, the scale used should enable the partner to easily draw the elements on the 'working map'. If preferred/available a field computer may also be used.

Step 5: Mapping the landscape sectors

The **TIMING** of mapping will depend on your case study crop. It is suggested that it undertaken during the active period for the partners ecosystem services.

A **recording sheet** for the mapping and necessary field information (habitat & management codes, SNH definitions) is to be found at the end of this document. **For each element mapped** add a number starting with '1' on the recording sheet and to the corresponding element on the map. **For each element** record the information relevant as detailed in the recording sheet, e.g. habitat type, height, width

In the field the following will be mapped

1. **ALL the 5 SNH types** present in the landscape sector will be mapped (Figure 4)
2. **All crops** as outlined in Table 1 will mapped throughout the entire LS
3. For **ALL Linear SNH** an estimated **width in metres** of the element will be noted on the recording sheet or directly on the aerial photograph
4. For **ALL Linear SNH** an estimated **height in metres** of the element will be noted on the recording sheet or directly on the aerial photograph. The height measured is to be an 'average' estimation for the element at the edge of the linear habitat being mapped.

5. For **ALL WA SNH** an estimated **height in metres** of the element will be noted on the recording sheet or directly on the aerial photograph. The height measured is to be an 'average' estimation for the element at the edge of the aerial habitat being mapped.
6. For **ALL water courses**, a **width is to be recorded** if necessary, for buffering purposes (see also section 3)
7. For **ALL orchards** a management code will be allocated (see Table 2 for codes)
8. For **ALL grasslands** a management code will be allocated. A management code will firstly be allocated to indicate whether the grassland is permanent or rotational and a further code to indicate mowing, grazing, hay cutting or multiple systems (see Table 2 for codes)
9. **Other elements** that are **relevant to the case study in question** may also be mapped
10. **The remaining elements** need not be mapped but can be defined in the GIS environment as non-habitat, e.g. roads etc.
11. For **ONLY the SNH types that border the FF** the traits will be measured as per WP2 (Protocol in preparation)
12. The **management of the crop fields adjacent to the FF** will be collected through an interview with the farmer at a later date (Protocol in preparation)

Mapping tips

It is recommended to keep the mapping as 'simple' as possible. Here are some examples.

If two a HL linear element runs parallel to a WL linear element they should be treated as ONE element **IF the HL element is less than 3m wide**. The woody element should be given priority in such cases. Depending on the width the element it would then be defined as either a WL or WA.



If two WL elements run parallel to each other, separated by a narrow strip of non-habitat they should/can be mapped and digitised as one element. This is especially the case if the canopy of the two elements closes above the element of non-habitat. For example, below the entire element would be categorised as a WL.



WL and HL SNH must be >50m long and at least 1.5m wide to be counted as separate elements. **If within a WL or HL element** there is a small length (<50m) of the other linear SNH, the element being mapped maintains the original code designation. For example if a small section of HL (<50m) is observed in a WL element, the element retains the WL classification.

Farm tracks are to be categorised as HL if they have more than 30% herbaceous cover and are wider than 1.5m

In cases of indecision between WL and HL elements, the WL element should be given priority.

Figure 4: Decision tree for the SNH type classification

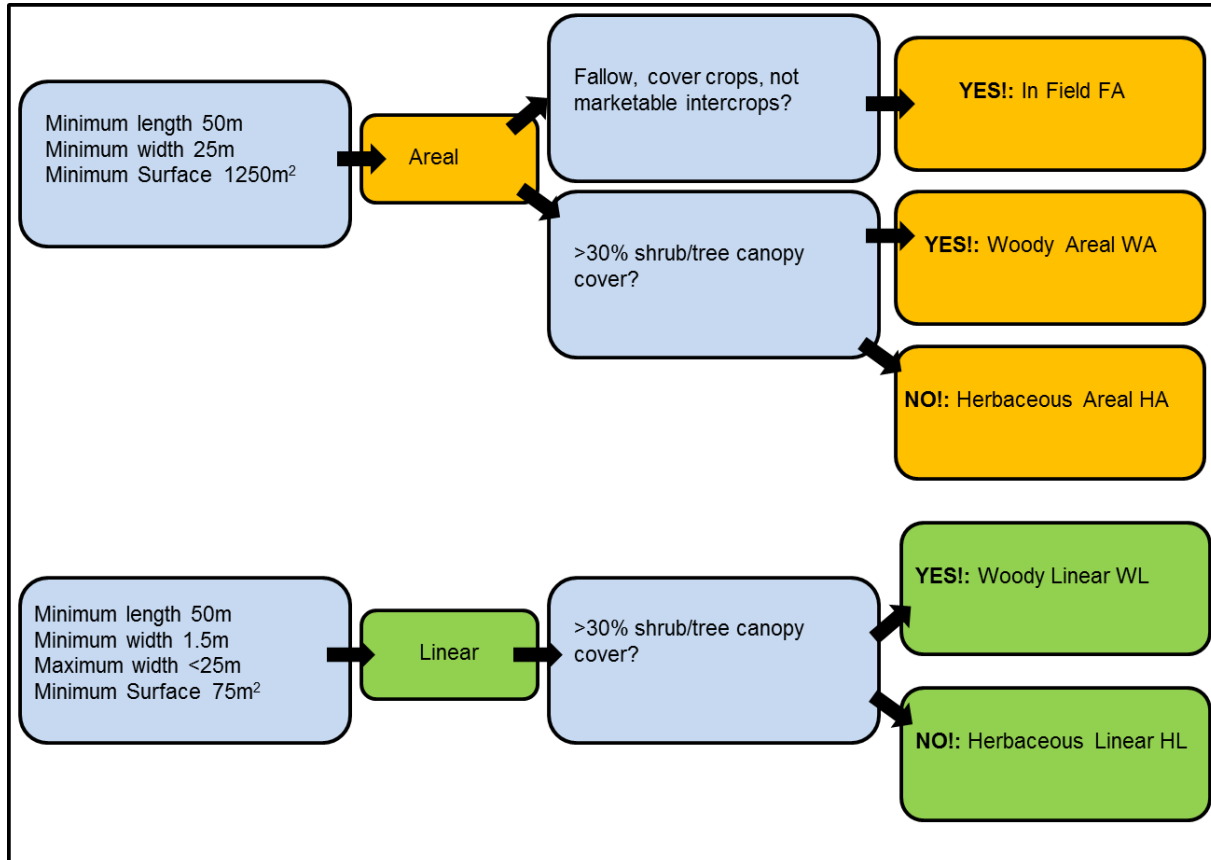

Table 2: Management codes for a) orchards and b), c) grasslands

a) Orchards

	Code
Low-stem intensive	1
High-stem Orchard	2

b) Grasslands: permanent versus rotational

Main management	Code
Permanent	1
Rotational	2

c) Grasslands, management

Management	Code
Mown	1

Grazed	2
Hay-cut	3
Multiple systems	4

Step 6 & 7: Digitise the maps in GIS, validate and transfer data

1. Digitise the elements that you mapped for your landscape sector in GIS
2. The geo-referencing system should be the LAEA coordinate system (see section 5)
3. The unit of the GIS is metres
4. All elements are to be digitised as polygons
5. If you recorded solitary trees in your region these should be digitised as points
6. The data to be recorded in your attribute table is detailed in the next section
7. Metadata should be attributed to the maps (see section 7).
8. The data should be validated, e.g. topology of the maps, codes in the attribute table
9. Shape files should be used to transfer GIS data to other partners. Individual shape files (that include the LAEA geo-referencing system) for each sector should be used.

3.2.6.10 The attribute table

The attribute table **MUST** include columns detailed in Table 3. Each partner should use the same format for the column names and the codes in Table 3. An empty example shape file that includes the definition/labelling of the attribute table can be found on the Huddle platform (QUESSA\WP3\7 – Habitat mapping)

Table 3: Column names and codes to be used in the attribute table

Column Name	Codes to be used in column	Note
COUNTRY	See Table 4 for codes	
CASESTUDY	See Table 4 for codes	
LANDSEC	e.g. 1 for landscape sector 1 etc.	This is the number of your landscape sector
ELEMENTNR	1,2,3,4,5,6..X	This is the number that you designated to your elements during mapping
FOCALFIELD	1 = YES 0 = NO	
HABITAT	Use codes from Table 1	
SNHADJ	1 = YES 0 = NO	SNH adjacent to FF
LINWID	No code, a numerical width estimate	Estimated width of linear SNH in metres
LINHGT	No code, a numerical height estimate	Estimated height of linear SNH in metres
AREHGT	No code, a numerical height estimate	Estimated height of areal SNH in metres
WATWID	No code, a numerical width estimate	Estimated width of water courses in metres
ORCHTYP	1 = low-stem 2 = high-stem	See Table 2, a)
GRASSTYP	1 = Permanent 2 = Rotational	See Table 2, b)
GRASSMAN	1 = Mown 2 = Grazed 3 = Hay-cut 4 = Multiple systems	See Table 2, c)
SCORE	No code, a numerical score for the SNH	This is the value calculated for the SNH based on WP2
AREA		Needs to be generated in GIS
LENGTH		Needs to be generated in GIS

Table 4: Codes to be used for the country and the case study

Country code	Case study code
UK	WHE_PC
UK	OSR_PO
FR	VIN_PC1
FR	VIN_PC2
DE	PUM_PC_PO
CH	OSR_PC_PO
HU	WHE_PC
HU	SUN_PO
NL	PEA_PC_PO
IT	OLI_PC
IT	SUN_PO
EE	OSR_PC_PO

3.2.6.11 Practicalities and estimated effort

Preparation for the field mapping (steps 1 to 4) will probably take around 0.5 days per sector.

For the field mapping (step 5) it is most efficient if you use a team of two people (driver + mapper). It is estimated that you will need 2 days for the mapping per sector.

The digitising and completion of the attribute table will also take around 1 day per sector (steps 6 & 7).

3.2.6.12 References

Bunce et al. (2010) Handbook for surveillance and monitoring of habitats, vegetation and selected species, Alterra-EBONE Handbook Version 20100510 (Huddle: QUESSA\WP3\7 – Habitat mapping)

Habitat Codes

¹ Depending on the case study partners may wish to map certain crops in more detail throughout the landscape sector. It is up to the individual partners to decide upon special requirements for their individual case studies. Further categories may be treated as case study specific.

² Please note *Medicago sativa* is listed here as a separate category. This is because it may be necessary to identify this crop in further analyses or to reclassify it as an HA habitat.

HABITAT	Code
Semi-natural habitat (SNH)	
WA: natural or semi-natural woody areal elements	1.01
WL: woody linear elements	1.02
HA: herbaceous areal elements	1.03
HL: herbaceous linear elements	1.04
FA: Temporary in-field SNH	1.05
Crops¹	
Annual herbaceous Crops	
Cultivated Bare Ground	2.01
Wheat (<i>Triticum aestivum</i> & associated sp)	2.02
Barley (<i>Hordeum sativum</i>)	2.03
Oats (<i>Avena sativa</i>)	2.04
Rye (<i>Secale cereale</i>)	2.05
Triticale (hybrids between wheat & rye)	2.06
Rice (<i>Oryza sativa</i>)	2.07
Sugar beet (<i>Beta oleracea</i>)	2.08
Fodder crops (e.g. <i>Brassica oleracea</i>)	2.09
Potato (<i>Solanum tuberosum</i>)	2.10
Field beans (<i>Vicia faba</i>)	2.11
Peas (all types) (<i>Pisum spp</i>)	2.12
Maize (<i>Zea mays</i>)	2.13
Oilseed rape (<i>Brassica</i> hybrid)	2.14
Sunflower (<i>Helianthus annuus</i>)	2.15
Pumpkin (all types) (e.g. <i>Cucurbita spp</i>)	2.16
Flowers	2.17
Commercial horticulture	2.18
Vines	2.19
Cover crop	2.20
Forage crop	2.21
<i>Medicago sativa</i> ²	2.22
Rotational grassland < 5 years old	2.23
Interrupted grassland	2.24
Perennial herbaceous crops	
Asparagus (<i>Asparagus sp</i>)	3.01
Rotational grassland >5 years old	3.02
Permanent grassland (NOT SNH)	3.03
Perennial woody crops	

Vines (<i>Vitis vinifera</i>)	4.01
Olives (<i>Olea europea</i>)	4.02
Cherries (<i>Prunus</i> spp.)	4.03
Apples (<i>Malus</i> spp.)	4.04
Pears (<i>Pyrus</i> spp.)	4.05
Walnuts (<i>Juglans</i> spp.)	4.06
Citrus fruit (<i>Citrus</i> spp.)	4.07
Hazelnuts (<i>Corylus avellana</i>)	4.08
Almonds (<i>Prunus amygdalus</i>)	4.09
Prickly pear (<i>Opuntia</i> spp.)	4.10
Pistacio nuts (<i>Pistacia sativa</i>)	4.11
Apricots (<i>Prunus amygdalus</i>)	4.12
Peaches/Nectarines (<i>Prunus persica</i>)	4.13
Urban areas	
Urban area, % of green area in element <25%	5.01
Urban area, % of green area in element 26 to 50%	5.02
Urban area, % of green area in element 51 to 75%	5.03
Urban area, % of green area in element >75%	5.04
Water courses	
(e.g. rivers, streams, canals, ditches >1.5m wide)	6.0
Non-Habitat	
(e.g. roads, lakes)	7.0

Management Codes

a) Orchards

	Code
Low-stem intensive	1
High-stem Orchard	2

b) Grasslands: permanent versus rotational

Main management	Code
Permanent	1
Rotational	2

c) Grasslands, management

Management	Code
Mown	1
Grazed	2
Hay-cut	3
Multiple systems	4

Minimum Mapping Unit (MMU)

The **minimum mapping unit (MMU) definitions** are as follows:

- Any element (SNH, crop, urban area, water course) selected for mapping in the landscape sector needs to have a **minimum surface area of 75m²**, in order to guarantee a minimum impact on beneficial and therefore on ES delivery.
- **SNH Linear Elements** (WL, HL) should have a **minimum width of 1.5m** and a **maximum width of <25m**. They must be **at least 50m in length**.
- **SNH Areal Elements** (WA, HA, FA) should be **at least 25m wide and at least 50m in length**.
- **The remaining elements** (crops, water courses, urban areas) must be a **minimum width of 1.5m and at least 50m in length**.

SNH classification tree

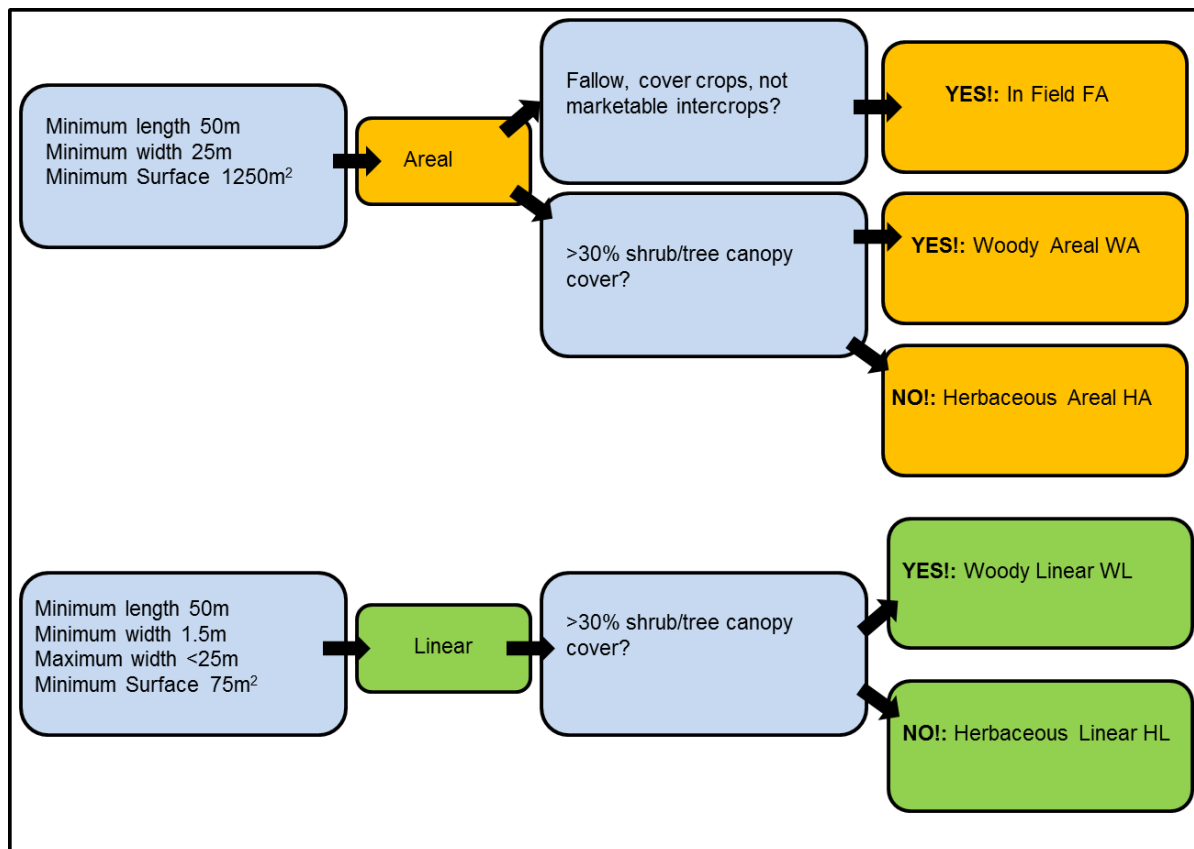

3.3 Estimating ecosystem service provision and providers

Proposed by Matthias Albrecht, Martin Entling, John Holland, Philippe Jeanneret Camilla Moonen, Sonja Pfister, Barbara Smith, Louis Suter, Mark Szalai, Maarten Van Helden, Eve Veromann

Compiled by Philippe Jeanneret

In the focal fields, assessment of the following variables will be achieved in transects and on measurement points (Figure 7):

- Sentinels: invertebrates and seed cards (see section 3.3.2.1): 4 measurement points on each of 2 transects,
- Predation/parasitism rate of the crop specific pest: 4 measurement points on each of 2 transects,
- Ground-dwelling natural enemies: pitfalls (see section 3.3.3.1): 4 measurement points on 1 transect,
- Pollinators and flying natural enemies: pan traps and sticky traps (see section 3.3.3.2): 4 measurement points on 1 transect,
- Pollination, visitation rate: 4 measurement points on at least 1 transect (at least 1 measurement at each of the 4 within-field distances, depending on response variable measured or method, respectively, see WP 3 pollination protocol).

3.3.1 Layout for in-field measurements

- 1) In each focal field, **1 transect with 4 measurement points is set up for the assessment of sentinels, predation/parasitism of the crop specific pest, natural enemies, pollinators and pollination. For the assessment of predation on sentinels only, a second transect with 4 additional measurement points is set up** parallel to the first one at 10 m distance (Figure 7).
- 2) **Focal fields will be selected in order to minimize the influence of their other margins on transects and measurement points set on the focus side** (Figure 7). Ideally, the other sides of the focal fields should not have any SNH, i.e. should be adjacent to another crop or with an as narrow as possible SNH (in WP2, definition of SNH was to be wider than 1.5 m, so narrower than 1.5 m is considered non-SNH or without influence). Habitats and elements of the non-focus sides have to be recorded.
- 3) To further minimize the influence of the other margins on the focus side, **the distance of the measurement points to the nearest field (non-focus) side must be equal or larger than the transect length + 1/4 ('b' Figure 7). The transect length ('a' Figure 7) should be at least 25m and up to 75m. Measurement points should then be distributed with regular distances in between, the nearest point to the margin being 2m. Distance 'a' and measurement point positions are the same for all focal fields in the case study.**
- 4) Example: the dimensions of the smallest field should be 56.25 x 62.5m calculated as follows: $25 + (25 + 6.25) = 56.25\text{m}$ and $10 + 2 \cdot (25 + 6.25) = 72.5\text{m}$. Its area will be 0.4 ha. Measurement points will be at 2 (mandatory), 9.7, 17.3 and 25m. If fields are not rectangular, the distance of 56.25m

(‘b’) should be respected in any direction (except on the focus side) from the measurement points.

- 5) Important remark: larger fields should be preferred and selected first. For small fields, then, the influence of the other margins should be reduced by selecting the fields which have no bordering SNH.

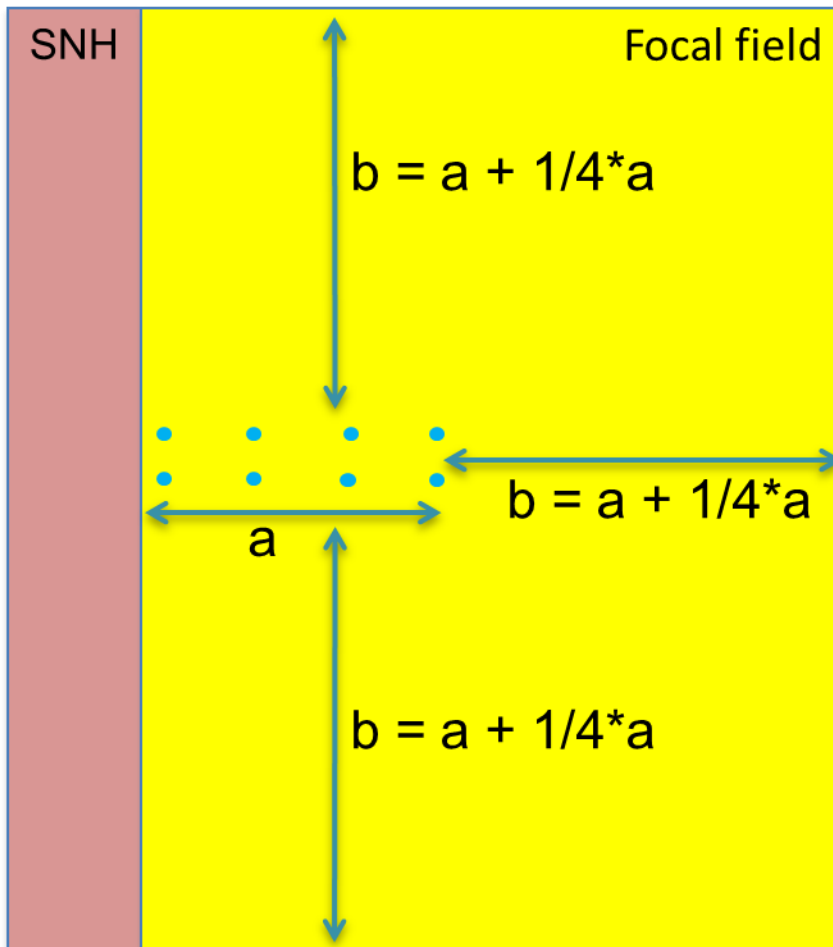

Figure 7: In-field design of transects and measurement points (blue points) on the focus side, and distances to the other field margins.

3.3.2 The use of invertebrate and seed sentinels to assess general predation and parasitism

According to the results of tests conducted in 2013 (section 2.5), protocols were developed and finalized for the assessments of 2014.

3.3.2.1 Predation on sentinel seeds

- 1) The seeds of two plant species, **Poa trivialis** and **Chenopodium album**, are exposed to predation on 8 measurement points in two transects per focal field (Figure 7). **Per measurement point, 20 seeds of each plant species are placed on the same seed card but separated to make easier the species-specific recording.**

- 2) **Seeds are stuck on white dry stick cards** supplied by Oecos <http://www.oecos.co.uk/dry%20stick.htm> or other adapted cards (size about 25 x 10 cm). Seeds are to be scattered on the card. The remaining card should be scattered with a fine sand (or sieved soil of FFs) to stop the invertebrates sticking to the card (see Westerman 2003). Nails will be used to secure the cards to the ground.
- 3) Cards are covered with a 1 x 1 cm wire mesh to avoid predation/exploitation by bigger predators (birds, mammals).
- 4) **Exposure in the field is 7 days.** Exposure of baits should start (and end up) in all the 18 focal fields within as short a time as possible.
- 5) Timing: as a general rule, **seed predation is measured 2 times during the season.** Timing should be established according to ecological (early and peak pest infestation) and agronomic (treatments) considerations, and/or should match with the period of the service wanted.
- 6) Plates should be at least at 1 m distance from Calliphora and Ephestia eggs plates (see below).

3.3.2.2 *Predation on animal prey*

3.3.2.2.1 *On the ground*

- 1) On the ground, **living Calliphora larvae** are exposed on Styrofoam plates on 8 measurement points in two transects per focal field (Figure 7). Calliphora larvae are selected as they are easy to use and show general predation conditions.
- 2) **10 living Calliphora larvae** are pinned on a 20 x 20 cm Styrofoam plate (or smaller if convenient) to be dug into the soil congruent with the soil surface. The larvae should be pinned with thin entomological pins (Nr. 1) and at the very caudal end to ensure survival.
- 3) **Measurement is the number of larvae eaten** (number of eaten preys with precision level = 1/3, e.g. 4 preys completely eaten + 2/3 of the fifth one = 4,66).
- 4) **Ephestia egg masses are exposed on sand paper or regular paper** (paper slightly waterproof to avoid destruction from rain is an advantage if no nice weather can be foreseen for 24 h). To best mimic Lepidoptera egg-laying, eggs are disposed in each of the four corners of the paper sheet on a surface of 0.25 cm². The small 0.25 cm² surfaces are previously covered with Arabic glue or adapted glue. Alternatively, adhesive cards can also be used (only the four small corner surfaces must then be sticky and not the whole card). **Measurement is the surface of eggs eaten.**
- 5) **Plates and sand paper should be covered each with an individual meshed (ca. 1 x 1 cm) wire mesh** to avoid predation/exploitation by bigger predators (especially corvids seems to be an issue).
- 6) **The duration of exposure in the field is 24 hours.** Exposure of baits should start (and end up) in all the 18 focal fields within as short a time as possible.
- 7) Timing: as a general rule, **general predation is measured 2 times during the season.** Timing should be established according to ecological (early and peak pest infestation) and agronomic (treatments) considerations, and/or should match with the period of the service wanted.
- 8) Plates should be at least at 1 m distance from seed cards.

3.3.2.2.2 On the plants

- 1) **Epehstia eggs are exposed, glued on a piece of sand paper or regular paper** (paper slightly waterproof to avoid destruction from rain is an advantage if no nice weather can be foreseen for 24 h) on 8 measurement points in two transects per focal field (Figure 7).
- 2) The Epehstia eggs cover 0.25 cm² of a 1 x 2 cm piece of paper **stapled to a leaf or around the stem of the plant**.
- 3) **The duration of exposure in the field is 24 hours**. Exposure of baits should start (and end up) in all the 18 focal fields within as short a time as possible.
- 4) Timing: as a general rule, **general predation is measured 2 times during the season**. Timing should be established according to ecological (early and peak pest infestation) and agronomic (treatments) considerations, and/or should match with the period of the service wanted.

3.3.3 The assessment of natural enemies as ecosystem service providers of predation

3.3.3.1 Pitfall traps for ground-dwelling predators in focal fields

This measurement is optional but warmly recommended to achieve because knowledge on densities of service providers in fields may help to understand the role of SNH for the measured service provision (predation on sentinels and on crop specific pests). **This concerns case studies where pest control will be investigated.**

- a) Ground-dwelling natural enemies are collected with pitfall traps early 2014 **in 18 focal fields on 4 measurement points on one transect, each measurement point with 1 trap for a total of 4 traps per focal field** (Figure 7).
- b) **Two surveys of 7 days each** will be conducted (parallel to pan traps, see section 3.3.3.2). Timing should be established according to ecological (early and peak pest infestation) and agronomic (treatments) considerations, and/or should match with the period of the service wanted. The goal is to estimate the activity density of natural enemies when pest control is required.
- c) After exposure, the trap is removed, the liquid discarded and the arthropods transferred to 70% ethanol. Keep the different sampling dates and the four traps per field in separate, clearly labeled containers (e.g. 20 ml vials).
- d) Pitfall traps consist of polypropylene cups sunk into the soil so that the rim is level with the ground surface. The rim must not project over the ground surface – better push it 0-5 mm below the surface to be on the safe side. Even small arthropods must be able to fall into the trap from every direction without having to climb the rim of the cup. Use the following digging tool to create the holes into which cups can be sunk:



- e) Cups have an opening of 66 mm and are 70 mm deep (e.g. yoghurt cups). Each cup is filled with 80 ml of a 1 : 3 mixture of propylene glycol and water with some drops of scentless detergent (e.g. sodium dodecyl sulfate) to break the surface tension. **Do not use funnels or roofs.** If you are unable to obtain the described plastic cups, UKL can send you some upon request.
- f) Specimens will be sorted into functional and taxonomic groups and counted, after the same scheme as in WP2 pitfalls. Slugs are an interesting by catch as they invade crops from SNH and can be damaging e.g. to oilseed rape, so it would be interesting to compare how vegetation traits influence densities of pest slugs. Carabids and spiders will be determined to species by UKL (at least for the UKL catches).

3.3.3.2 *Pan traps or sticky traps for natural enemies and pollinators in focal fields*

This measurement is optional but warmly recommended to achieve because knowledge on densities of service providers in fields may help to understand the role of SNH for the measured service provision (predation on sentinels and on crop specific pests). Besides the measured explanatory variables (bordering SNH type, proportion of SNH, management), there are many other explanatory variables that could explain differences of predation rates on sentinels and crop specific pests. The most logical and probably most powerful one is the presence and abundance of the service providers. Then, results about ES might poorly be interpretable if no data are provided on service providers in such a study.

- a) Natural enemies and pollinators are collected **with yellow pan traps** (blue and white pans are dropped out for work load reason) **or sticky traps** early 2014 **in 18 focal fields on 4 measurement points on one transect, each measurement point with 1 trap for a total of 4 traps per focal field** (Figure 7).
- b) **Three surveys of four days each** will be conducted (parallel to pitfall traps, see section 3.3.3.1). Timing of surveys should be defined specifically for each crop according to early and peak infestation. The goal is to estimate the activity density of natural enemies when pest control is required.

Remark: In case studies where pest control and pollination are investigated in the same crop (pear in NL, pumpkin in DE, oilseed rape in CH, EE) two sets of three surveys may be necessary in case requirements for pollination and pest control of the crop do not overlap in time.

3.3.3.2.1 Pan traps

- a) To enhance the attractiveness of pan traps especially in the UV-spectra (Droege 2006), the pans (500-mL plastic soup bowls, Pro-Pac, Vechta, Germany) will be painted with UV-bright yellow

(Sparvar Leuchtfarbe, Spray Color GmbH, Merzenich, Germany). Although three colours would be better as preliminary results of 2013 surveys showed differences in responses among species groups, blue and white pans are dropped out for work load reason.

- b) The pans will be mounted on a wooden post 10-20 cm lower than the height of the crop, so that they cannot be seen when viewing the field horizontally from outside. This is to avoid attraction of insects from large distances, as we are interested in measuring activity within the focal field. However, pans must be visible from above, so any vegetation hanging over the trap from the side should be removed.
- c) Each pan is filled with 300ml water with scentless detergent (e.g. washing powder) to reduce surface tension. In case of rapid evaporation, glycol can be used alternatively.
- d) All collected insects will be labelled and stored separately for each pan in 70% ethanol.
- e) Out of the pan traps, species groups of natural enemies and pollinators can be sorted out depending on the CS specific pest they potentially control.

3.3.3.2 Sticky traps

- a) Preparation: Heat the Oecotak insect trapping glue (www.aecos.co.uk) in a water bath until the glue is soft enough to spread with a paint brush. Coat one side of each acetate sheet (overhead projector acetates A4 size) with a thin film of glue and allow to cool. Cover glue with a non-sticky film and place in a plastic bag.
- b) Operation: Hammer wooden post into the ground so it is secure, top should be above the level of the vegetation even when fully grown. Attach plastic bottle (2 litre plastic bottle, supermarket own brand water bottles were cheapest) to the wooden post using a screw. Attach bottle to its lid, bottle will now be upside down. Wrap acetate around the bottle and back on itself, remove non-stick film cover to set the trap.
- c) For very tall fast growing vegetation then use two wooden posts, one in the ground the other with predrilled holes and bolts so it can be raised as the crop grows.
- d) Collection: Attach label to sticky trap and cover with non-stick clear film, detach from bottle and place in a labelled plastic bag. Store in a box and freeze on day of collection.
- e) Identification: Remove sticky trap from plastic bag and observe invertebrates under a binocular microscope. See SOP for Identification of invertebrates on sticky traps.

3.3.3.3 Estimation of effort

Excel spreadsheets were made available on the Huddle platform for partner to fill in with effort required for crop specific pest measurements, i.e. pest density, pest predation and parasitism. Time necessary to record traits of SNH (larger and finer scale) can be derived from the 2013 exercise (without the complete vegetation assessment).

3.3.4 Case study specific assessment of pest density, damages and pest predation

This section relates assessments which, on the one side, already occurred during the 2014 field season, and on the other side, are still ongoing.

3.3.4.1 *Pear psylla in pear orchard in the Netherlands*

Herman Helsen, Bart van der Sluis and Bart Heijne

Crop: Pear orchards

Pest: pear psylla *Cacopsylla pyri*

Sentinel: Pear psylla eggs on pear leaves, exposed in the field for 24 hours.

3.3.4.1.1 Method

Adult pear psyllids were collected from the field and concentrated in sleeve cages on pear trees to lay eggs. After a five day egg laying period, leaves with eggs were collected and the number of eggs per leaf was counted. Leaves were put into plastic vials filled with water and exposed in pear trees for 24 hours. At the end of the exposure period leaves were transferred to the laboratory and the remaining number of eggs was counted.

3.3.4.1.2 Experimental design:

- Per focal field: 4 measurement points on 1 transect
- Per focal field: four leaves in cages as a reference
- Exposure: end of June

3.3.4.1.3 Discussion on methodology

In the first 2014 experiment we used larvae as a sentinel, following the original protocol. We observed that these larvae moved away from the leaves during the 24 hour exposure period, probably as a result of the deterioration of the leaves at high summer temperatures at the time. Therefore it was decided to use psylla eggs as a sentinel in the second experiment.

3.3.4.2 *Wheat in United Kingdom*

John Holland and Barbara Smith

3.3.4.2.1 Pest density

Pest density in Winter Wheat will be assessed by 1) direct aphid counts in the field, 2) direct cereal leaf beetle larvae counts in the field, 3) estimate of leaf damage caused by cereal leaf beetle in the field, 3) sticky traps as verification.

1) Direct aphid counts

In each field 25 plants were randomly selected at each of four locations on one transect and all aphids on the tillers were counted. Leaves were also inspected and all aphids counted. Numbers of mummified aphids were recorded. Assessments were made in the first week of July. 25 plants at each distance were sampled = 100 plants per field.

2) Cereal leaf beetle assessments

In each field 25 plants were randomly selected at each of four locations on one transect and were inspected for cereal leaf beetle larvae. All larvae were counted. Assessments were made in the first week of July. 25 plants at each distance = 100 plants per field.

3) Leaf damage to indicate leaf beetle larvae presence was recorded.

In each field 25 plants were randomly selected at each of four locations on one transect and were inspected for cereal leaf beetle damage. Assessments were made in the first week of July. 25 plants at each distance = 100 plants per field.

4) Sticky traps

Because of low aphid densities in many fields, we wanted to verify the counts we make by using sticky traps. Sticky traps were placed at each of four distances to record predation and parasitism (diagram below). Sticky traps would also capture OWBM.

Sticky traps were set twice on 3rd June and 24th June and were left out for seven days.



3.3.4.2.2 Predation and parasitism

Winter wheat is sown in late summer, early autumn. Depending on the weather, local conditions and variety, sown inflorescences emerge in late spring (sometime around May) and grain hardens by July.

Aphids

Aphids cause yield reduction through direct feeding damage and diseases introduced by virus transmission. In UK winter wheat *Sitobium avenae* (the grain aphid) and *Rhopalosiphum padi* (the bird cherry-oat aphid) are the principle pests and the main vectors of *Barley yellow dwarf virus* (BYDV) in cereals transmitted by autumn/winter infestations. *S. avenae* causes direct feeding damage through May, June and early July, from the flag leaf to dough ripe stages. This species also has pest status in winter-sown cereals in September/October, and throughout mild winters as a virus vector of Barley yellow dwarf virus. It is more cold - hardy than *R. padi*, and thus more significant in the secondary spread of BYDV in winter cereals. *R. padi* moves from *Prunus padus* on which it overwinters after April into cereal crops, it rarely become abundant enough to cause direct feeding damage but it acts as a vector of BYDV. *Metopolophium dirhodum* (the rose grain aphid) affects wheat via direct feeding, it infests the lower leaves as the plants come into ear and if numbers increase they move up the plant. *M. dirhodum* is a poor vector of BYDV.

Depending on the year and variety sown, aphids begin to infest wheat in the spring, this can be as early as April but the period may extend to late May. Sampling will take place mid-June and early July.

Orange wheat blossom midge

Adults lay their eggs on the ears and the larvae feed on the ears causing yield loss and reductions in grain quality. Infestations are sporadic because midge hatch is dependent on overwinter temperatures and rainfall. Adult midges can be monitored using sticky traps. Predation is most important once larvae finish feeding on the grain and fall from the ears, but before they have chance to bury into the ground and form cocoons. It is not possible to rear OWBM larvae therefore *Drosophila* pupae which are a similar size will be used as a surrogate. The predominant predators of OWBM adults are predatory flies and Araneae whilst larvae and pupae on the ground are predated by Carabidae. Adult midges are active at ear emergence and can be monitored with pheromone traps or yellow sticky traps. Yellow sticky traps will be deployed as part of pest density monitoring (see the *Assessment of Pest Density* section).

Predation

The predominant predators of aphids are those attacking aphids on the plants (e.g. Syrphidae, Coccinellidae, Carabidae, Staphylinidae) and on the ground as aphids constantly falling and re-climbing (Carabidae, Araneae). Aphid predation will be quantified using 1) Aphid bait cards / tags attached to ears of wheat; the measurement will be percentage predated. 2)

Drosophila pupae cards (as a surrogate for OWBM) placed on the ground and covered with exclusion cages; the measurement will be pupae predated.

Aphid bait tags

10 living cereal aphids (*Sitobion avenae*) will be exposed on each of two sentinel plants at each of 4 distances on each of two transsects. Aphids will be stuck on drystick (4 x 1 cm) and sprinkled with sand. These tags will then be stapled to the leaf on the wheat plant.



***Drosophila* bait cards**

10 x *Drosophila* pupae will be stuck on drystick and which will then be sprinkled with sand (10 x 5cm). The cards will be placed on the ground and held in place using nails. 1 card will be put out at 8 locations in each field on each occasion. Cards will be covered using a mesh cage (mesh size ca. 1 x 1cm) to avoid predation/ exploitation by bigger predators.

Design

There will be two transect s running perpendicular to the SNH boundary edge, with four locations on each transect. Length of transect will be dictated by the size of focal fields as indicated in Figure below

- 2 randomly selected wheat plants each with an aphid bait tags
- 2 *Drosophila* bait cards placed on the ground each with exclusion cages

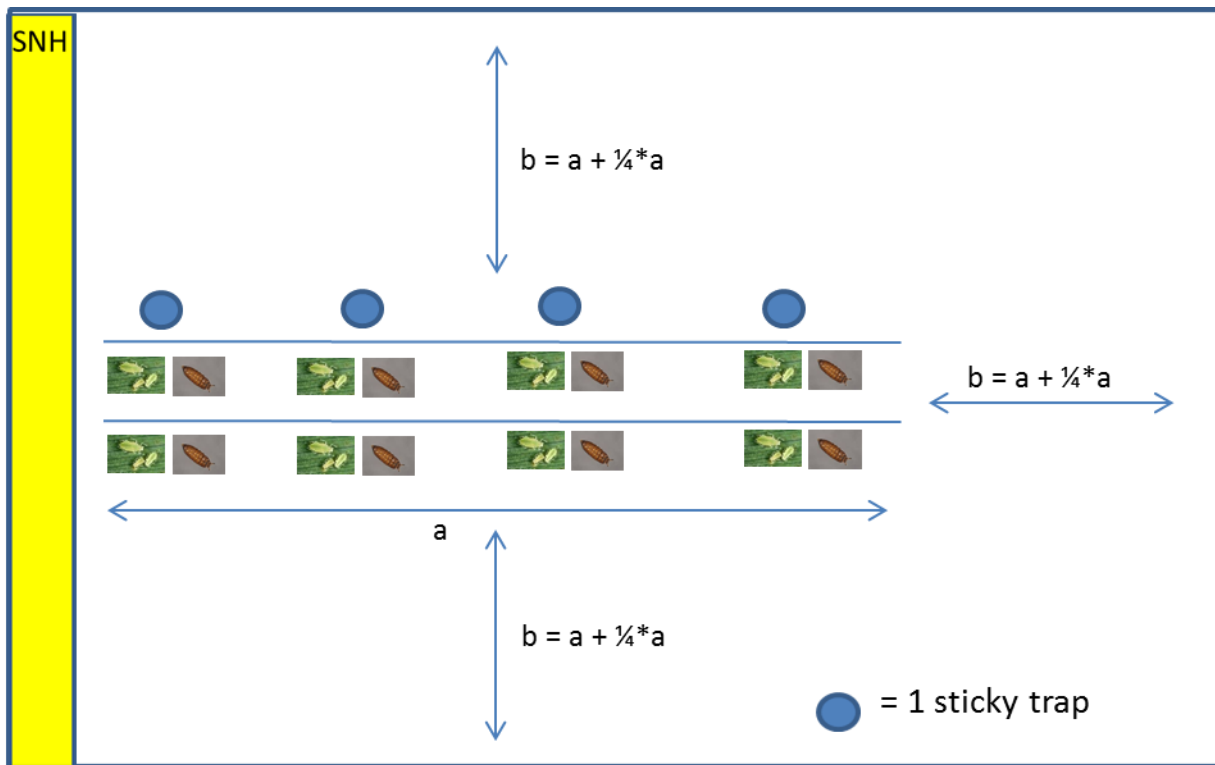

Method	Landscape sector	Sampling occasion	Transect	Location on transect	Replicate	Total
Aphid tags (on plant)	18	2	2	4	1	288
<i>Drosophila</i> bait cards	18	2	2	4	1	288

Cages for Drosophila	18	2	2	4	1	144
----------------------	----	---	---	---	---	-----

3.3.4.3 Vineyard in France

Maarten van Helden and Brice Giffard

Pests observed will be *Lobesia botrana* (tortricidae) and *Empoasca vitis* (cicadellidae).

Pest densities will be observed :

- For adults using attractive insect traps (pheromone attraction for *Lobesia botrana*, colour attraction for *Empoasca*). A single trap will be installed in each focal field and will be checked weekly during season (April till August). Pheromone dispensers and sticky plates will be changed every second week.
- For larvae: At peak densities of the pests' larval populations (3-4 weeks after flight peaks) counts will be performed (number of 'glomérules' per 160 grapes, number of punctured berries per 160 grapes, number of larvae for 160 leaves). Observation will focus on the two first generations only. Counting will be done at similar distances than predation measures (4 distances) and at two points at each distance (2 transects). Counting will be repeated during 2-3 weeks to precisely estimate levels of population between fields.
- Parasitism will be recorded on leafrollers only, by collecting up to 100 larvae per plots during the first and second generation and by rearing them out in the lab. Populations are generally low, so we can probably not do this on a transect basis but will collect over the whole field and record larval position. Abundance level of *Lobesia botrana* was very low in 2014 in the oceanic site (Libournais) for the two first generations and this experiment has been cancelled. Abundance was higher in Languedoc (Mediterranean site) but we observed very large mortality of caterpillars during their rearing (disease due to fungi, bad conditions of rearing). Only ca. 5% of collected caterpillars emerged and no parasitism has been observed. We will improve our knowledge about this kind of experiments during winter 2014 and try to replicate it during 2015 growing season.
- We will test sentinel pupa of *Lobesia botrana* or related species during winter 2014 and 2015. Long exposure is possible. 5 pupae will be exposed at 8 points in each plot, and predation level will be recorded 7 days after exposure.
- Predation of leafhopper larvae will be assessed using aphid cards exposed to predation during the peak of presence of leafhopper larvae both in 2014 and 2015. 5 frozen aphids are stucked to a paper card and 8 cards are exposed in each field (40 proposed aphids per field) using the same transects and distances used for measuring general predation.

3.3.4.4 Pumpkin in Germany

Martin Entling and Sonja Pfister

3.3.4.4.1 Pest density

Crop: Cucurbita maxima

Pest: aphids

Method:

Aphid density will be measured on the four transect (at 2m, 10m, 18 and 26 m distance to the edge). The sampling effort will be adapted to aphid infestation (Ragsdale et al. 2007): When < 50% of the leaves are infested, the aphid density will be counted on 20 randomly selected leaves per distance. When > 50% and < 80% are infested, 10 leaves per distance will be sampled. When on > 80% of leaves aphids are found, 5 leaves per distance will be inspected. Irrespective of infestation level, the leaves will be picked along a transect of ~20 m parallel to the field edge. For analysis, all data will be converted to mean number of aphids per leaf per distance.

Time period:

Field will be investigated from the start of the growing season of pumpkin (May) until the natural aphid population on the pumpkin plants vanishes (end of July). The aphid density will be measured every two weeks and at the highest aphid density once per week.

2014: 6 runs, namely 28.-30.5.14, 11.-13.6.14, 18.-20.6.14, 25.-27.6.14, 10.-13.7.14, 23.7.-25.7.14.

Literature:

Ragsdale, D. W.; McCornack, B. P.; Venette, R. C.; Potter, B. D.; Macrae, I. V.; Hodgson, E. W.; O'Neal, M. E.; Johnson, K. D.; O'Neil, R. J.; Difonzo, C. D.; Hunt, Thomas E.; Glogoza, P. A.; and Cullen, E. M. (2007): Economic Threshold for Soybean Aphid (Hemiptera: Aphididae). In Faculty Publications: Department of Entomology, Paper 297, 1258-1267.

3.3.4.4.2 Predation and parasitism

Crop: Cucurbita sp.

Pest: aphids (*Aphis fabae*, *Myzus persicae* and other)

General approach: Determine (A) the influence of SNH on natural aphid control, (B) aphid densities in the field, which are the result of differences in natural infestation (mostly early in the season) and natural control (mostly later in the season), and (C) the relationship between aphid infestations and yield (quantity and quality of harvestable pumpkin).

A) Influence of SNH on natural aphid control:

In fields and within-field positions with different SNH levels (general QuESSA design), we will quantify the reduction of standardized aphid populations over time (14 days) at several (ca. 3) subsequent crop stages. The experimental units are single leaves of pumpkin of a standardized age (youngest leaf of a shoot for the second run). Leaves must be upright and any touching neighboring leaves are removed. In the first run (at the start of aphid infestation in the fields) *Aphis fabae* aphids reared in the lab will be used. In the second run aphids from the cage treatment from the first run are used. A standardized amount of aphids with a comparable age structure before the start of the experiments is used and natural immigration is prevented as far as possible. Naturally occurring winged aphids are removed. The

number of aphids in the first experimental run will be 10 per leaf. For subsequent runs, the number may be corrected according to the experience and the natural infestation levels in the field.

Table.1.4.1 Three treatments – open without aphids and development of aphids in open, half open and closed environments

	treatment	n/distance
A	Open, without aphids, immigration	2
B	Open, with 10 aphids, Pest control, immigration, emigration + development	2
C	Exclusion cage: 10 aphids, development	2

Replicates:

4 distances per field x 2 replicates per distance per run x 3 treatments = 24 leaves per field per run

Start date:

Immigration of the aphids into the pumpkin fields (from May)

Repetition over time:

Each measurement over 14 days

Then start of a new one?

First run 4.6. – 20.6.2014

Second run 23.6. – 9.7.2014

Time needed in the field (for installation and counting):

2 person-minutes per leave x 24 leaves per field = 6 fields per day

visits every 7 days (one installation, two counts)

installation 2 persons 3 days

Aphids for infestation:

Rearing in the lab on reared pumpkin plants

10 days needed for full development

One adult aphid produces around 3 to 4 aphids per day and ~20 in total

place of origin: Julius-Kühn institute or cucumber greenhouse incubation period: 1.5 weeks

needed: 16 leaves/field x 10 aphids x 18 fields => 2880

➔ + buffer = 4000 aphids

+ aphids for yield experiment (2000 + buffer)

➔ 7000 aphids

500 adult aphids needed (adult, L4) or more than 4 weeks for rearing

Plants needed: every 2 weeks a new one (should have at least 3 leaves -> 3 weeks old)

At least (20) 30 plants at the end

At least 10 at the start

exclusion:

bagged with non-woven material (for tomatoes) and tied with a cable tie (fig. 1.4.2)



fig 1.4.2 treatments in the field

B) Aphid densities in the field See protocol “assessment of pest density”

C) Influence of aphids on pumpkin yield

Different levels of aphid infestation will be established on whole pumpkin plants, monitored over the season and yield measured. The aim is to determine the relationship between cumulative aphid-days and yield, in order to be able to translate the findings of (A) and (B) into yield differences.

5 treatments (0, 5, 20, 50, 100) x 8 replicates = 2000 aphids + buffer

All in exclusion cages (3 weeks) at the start, treatment for 3 weeks, then removal of the cages, because they damage the plants and inhibit plant growth.

Control/ counting once per week

Measurement: number of aphids, number of winged aphids, number of enemies (remove), male and female flowers, chlorophyll content of 3 randomly chosen mid-sized leaves, length of the twine, virus, number of twines and leaves

Literature

Chaplin-Kramer, Rebecca; Kremen, Claire (2012): Pest control experiments show benefits of complexity at landscape and local scales. In: *Ecological Applications* 22, S. 1936–1948.

Costamagna, Alejandro C.; Landis, Douglas A. (2006): Predators Exert Top-Down Control of Soybean Aphid across a Gradient of Agricultural Management Systems. In: *Ecological Applications* 16 (4), S. 1619–1628. Online verfügbar unter <http://www.jstor.org/stable/40062026>.

Gardiner, M. M.; Landis, Doug A.; Gratton, C.; DiFonzo, C. D.; O'Neal, M.; Chacon, J.M et al. (2009): Landscape diversity enhances biological control of an introduced crop pest in the north-central USA. In: *Ecological Applications* 19, S. 143–154.

Keiser, Carl N.; Sheeks, Lauren E.; Mondor, Edward B. (2013): The effect of microhabitat feeding site selection on aphid foraging and predation risk. In: *Arthropod-Plant Interactions* 7, S. 633–641.

McCarville, M. T.; Kanobe, C.; MacIntosh, G. C.; O'Neal, M. (2011): What Is the Economic Threshold of Soybean Aphids (Hemiptera: Aphididae) in Enemy-Free Space? In: *jnl. econ. entom.* 104 (3), S. 845–852.

Myers, Scott W.; Gratton, Claudio (2006): Influence of Potassium Fertility on Soybean Aphid, *Aphis glycines* Matsumura (Hemiptera: Aphididae), Population Dynamics at a Field and Regional Scale. In: *Environmental Entomology* 35, S. 219–227.

Ragsdale, D. W.; McCornack, B. P.; Venette, R. C.; Potter, B. D.; Macrae, I. V.; Hodgson, E. W.; O'Neal, M. E.; Johnson, K. D.; O'Neil, R. J.; DiFonzo, C. D.; Hunt, Thomas E.; Glogoza, P. A.; and Cullen, E. M. (2007): Economic Threshold for Soybean Aphid (Hemiptera: Aphididae). In Faculty Publications: Department of Entomology, Paper 297, 1258- 1267.

van Berg, H. Den; Ankasah, D.; Muhammad, A.; Rusli, R.; Widayanto, H. A.; Wirasto, H. B.; Yully, I. (1997): Evaluating the Role of Predation in Population Fluctuations of the Soybean Aphid *Aphis glycines* in Farmer's Fields in Indonesia. In: *Journal of Applied Ecology* 34 (4), S. 971–984. Online verfügbar unter <http://www.jstor.org/stable/2405287>.

Weisser, Wolfgang W.; Clement, Lars W. (2007): Handbook for measurement of aphid predation risk. Jena.

3.3.4.5 Oilseed rape in Switzerland

Louis Sutter and Matthias Albrecht

Response variables:

1. Pest level/Infestation:

... is measured by monitoring adults (tapping method and pan traps), and collected larvae

Damage:

... of the main pest is measured as percentage damaged buds, which not developed into flowers.

2. Parasitism:

... is measured as the percentage of collected/dropped larvae.

3. Predation:

... Is measured by comparison of re-emerging adult beetles from predator exclusion and control cylinders.

3.3.4.5.1 Pests and plant damage

We focus on the principal pest species, which is the pollen beetle *Meligethes aeneus/viridescens* (Coleoptera: Nitidulidae). To measure pest levels in our sectors we will, just as to measure natural enemies, use yellow pan traps (Alford 2003) during early spring and the standard trapping method.

Pest load:

Yellow pan traps open for 4 consecutive days. This means 18 sites x 10 traps. (1 yellow pan traps x 4 distances in the focal field + 2 sets of pan traps of each colour (yellow, white, blue) in the adjacent SNH, 10 traps per site, 180 per round, at least 2 rounds, 1= pest invasion, 2 = flowering.

- Same distances as other sampling (natural enemies, pollinators, yield)
- Pans are set at inflorescence height, has to be adjusted over the season.
- During bud stage, the tapping method gives most accurate results of pest abundance.
We tap the main raceme of the plant three times over a tray (30x20 white plastic tray), tapping must be strong enough to shake the beetles out from the buds/flowers but not to brake the raceme or shake some beetles out from the tray.
 - 10 plants per distance
 - At least once: 1. BBCH 52-55 2. BBCH 55-59
 - Count all pollen beetles in the tray

Plant damage:

We collected 10 plants per distance and counted blind stalks at BBCH 70-79 on main and one preliminarily marked side shoot.

3.3.4.5.2 Pest control (predation and parasitism) and other causes of mortality of the principal pest species, the pollen beetle

Method adapted from Büchi 2002.

To measure total mortalities of pollen beetle larvae and pupae at the beginning of April (BBCH 50), plastic cylinders (diameter 31 cm, height 15 cm) will be dug into the soil. The walls of the crates will have an opening at soil height to allow all (including ground dwelling) arthropods to enter the cylinder. To measure mortality that is not caused by predators at the same time, additional cylinders (diameter 31 cm, height 30 cm) without openings at soil height will likewise dug 15cm into the soil nearby. The bottom of each cylinder will be closed with wire gauze (1mm mesh). The cylinders will be filled up to 15cm (up to the surrounding soil surface height) with soil from the field. Before use, this soil will be dried at 100 degree C out to ensure that it will not contain any living predators. After the start of flowering (BBCH 60), funnels of the same diameter as the cylinders (31 cm) will be put into the fields. They will be placed in small polyethylene pots (500 ml) which will have a flexible opening to hold the funnels and will be dug into the soil. These funnels will be used to catch the pollen beetle L3-larvae falling down from the rape blossoms and to estimate their density. The vial below the funnel are emptied weekly. After the

flowering period (BBCH 69), the funnels will be removed. After all larvae will have reached the soil, cylinders will be closed with a fine meshed gauze (0.5mm × 0.7mm) to prevent escaping of the hatched pollen beetles. Yellow sticky traps will be put into both the crates and cylinders to catch the emerging pollen beetles. At the end of June (i.e. after the emergence of the pollen beetle), the pots beneath the funnels which contain the larvae will be weekly emptied over four weeks and the larvae will be stored in water and in the freezer. In the laboratory, the larvae will be dissected under the microscope and checked for parasitism.

This method will enable us to measure the pest load (amount of dropping larvae), and to disentangle different causes of mortality of *Meligethes*: (i) parasitism by parasitoids (% parasitized in funnels), (ii) predation by ground dwelling arthropods and (iii) mortality not due to arthropod natural enemies (soil, fungi, drought etc.)

3.3.4.6 Oilseed rape in Estonia

Eve Veromann, Riina Kaasik and Gabriella Kovacs

3.3.4.6.1 Pest density

Pollen beetle (PB) (*Meligethes aeneus*) densities on winter oilseed rape (WOSR) (*Brassica napus*):

Beating method to assess adult PB densities during the damage susceptible stage of WOSR (green-yellow bud, GS 51 – 57) and after the damage susceptible stage GS 60-65 (early to full flowering).

- 1) Sampling method: The main raceme of 10 randomly chosen plants at 4 distances 2, 25, 50 and 75 m distance from crop edge per field were beaten three times over a white tray on which all PB adults and larvae were counted. Sampling times: at BBCH 51-57; BBCH 57-59 and BBCH 61-65.
- 2) Sampling with yellow pan traps to assess flight activity of beetles. Traps were open for 4 consecutive days. This means 18 sites x 10 traps i.e. 1 yellow pan trap x 4 distances in the focal field + 2 sets of pan traps of each colour (yellow, white, blue) in the adjacent SNH, 10 traps per site, 180 per round. Sampling times: green bud stage of plants; beginning of flowering and full flowering of plants. Same distances as other sampling (natural enemies, pollinators, yield). Pans were set at inflorescence height, has to be adjusted over the season.

PB last instar larval densities on WOSR:

After the start of flowering (BBCH 60), 31 cm diameter funnels were put into the fields. They were placed in small polyethylene tubes (with a flexible lid to hold the funnels) which were dug into the soil. These funnels were used to catch pollen beetle L3-larvae falling from the OSR plants and to estimate their density. All tubes and funnels were emptied weekly and all larvae (including 1st instar fallen from plants due to rainfall or/and wind) were separated from WOSR petals, counted and stored in distilled water in eppendorf tubes in the freezer until further handling (measuring parasitism).

Oviposition densities via larval densities on WOSR

Flowers from 5 WOSR plants (BBCH 65-67) per field at 4 distances 2, 25, 50 and 75 m from crop edge were collected separately into plastic bags. All flowers were dissected in laboratory and all PB larvae were counted and stored in distilled water in eppendorf tubes in the freezer until further handling (measuring parasitism). The number of dissected flowers were counted as well.

Cabbage seed weevil (*Ceutorhynchus obstrictus*) abundance and parasitism rate

Assessment of abundance and parasitism level could be combined using the following:

Infestation of pods by *C. obstrictus* larvae and the presence of ectoparasitoids were assessed at the mature pod stage (BBCH 80–83 (Lancashire et al. 1991; Meier 2001)).

Five pods from the main raceme and five from the third side raceme were collected from 5 randomly chosen plants at 2, 25, 50 and 75 m from crop edge per field. The pods were incubated in emergence traps in the laboratory for four weeks (we use milk cartridges: each trap consists of a 500 ml carton bandbox with one side made of dark netting to allow air circulation and avoid mould growth and an exit hole equipped with a 50 ml cylindrical plastic vial (Eppendorf tube) into which the parasitoids emerged (Veromann et al., 2011). The dark netting is adhesive fabric ironed to the boxes. Four weeks later, emerged weevil larvae or parasitoid adults that were emerged from the pods were counted and identified. All pods were examined and counts made of larval and parasitoid exit holes (these could be distinguished because exit holes of *C. obstrictus* larvae are circular but irregular along their margins whereas parasitoid exit holes are smaller and rounded along their margins (Dosdall et al. 2006)). After examination, all pods were dissected and the remains of any weevil larvae or the pupae of parasitoids noted and counted. The percentages of pods infested by healthy and parasitized weevil larvae were calculated. Parasitoids of CSW pupate in pods, therefore we can identify the species and gender as well.

3.3.4.6.2 Predation and parasitism

Predation and mortality of the pollen beetle (PB) (*Meligethes aeneus*) (Method adapted from Büchi 2002)

To measure pollen beetle larval and pupal mortalities we used metal cylinders (diameter 31 cm, height 15 cm, Fig2.a) dug 5 cm into the ground. One set of cylinders were put out at the start of the flowering (before the dropping period of PB larvae to exclude ground dwelling predatory arthropods) and the second set at the end of the dropping period.

After the start of flowering (BBCH 60), funnels of the same diameter as the cylinders (31 cm, Fig1.c) were put into the fields. They were placed in small polyethylene tubes (with a flexible lid to hold the funnels) which were dug into the soil. These funnels were used to catch pollen beetle L3-larvae falling from the OSR plants and to estimate their density. All tubes and funnels were emptied weekly and all larvae (including 1st instar fallen from plants due to rainfall or/and wind) were separated from WOSR petals, counted and stored in distilled water in eppendorf tubes in the freezer until further handling (measuring parasitism).

At the end of the flowering period transparent sticky traps were placed inside each cylinder and all cylinders were covered with fine transparent fabric to prevent escaping of the hatched pollen beetles. After the flowering period (BBCH 71), the funnels were removed.



Fig. 2 Cylinder (a) and funnel (b) for estimation of pollen beetle abundance and predation.

Parasitism

Parasitism rate of Pollen beetle (PB) (*Meligethes aeneus*)

Experiment 1:

Flowers from 5 WOSR plants (BBCH 65-67) per field at 2 and 25, 50 and 75 m from crop edge were collected separately into plastic bags. All flowers were dissected in the laboratory and all PB larvae were counted. All larvae from one plant were collected into one Eppendorf tube filled with distilled water which then was stored in the freezer until the dissection. All 1st and 2nd instar PB larvae (separately) were dissected under a microscope and all parasitoids eggs and larvae were identified and counted.

Experiment 2:

All larvae collected from funnels were dissected in the laboratory under a microscope and all parasitoids eggs and all larvae were identified and counted.

We establish parasitism, multiparasitism (superparasitism as usually several *Diospilus capito* larvae found in one PB larvae, or multiparasitism if *D. capito*, *Phradis morionellus* and *Tersilochus heteroceris* (or any combination of these species) occur in one PB larvae).

For dissection we used green food colouring to reveal parasitoids' eggs and larvae (Super Cook, Green, Food Colouring, Cassie Brown's Cake Craft, airbrush food colour (diluted with yellow food colouring); not all brands work, it needs to be clear, not milky and not too dark as then the parasitoid larvae will be coloured instantly and can no longer be identified).

We put one PB larvae in one drop of food colouring, used two entomological needles (size 00) to remove head capsule and to squeeze the entrails of the larvae out (very carefully as we don't want to smash

parasitoids' larvae). All eggs and larvae of parasitoids were counted and identified (Updated key of Osborne P. 1960. Observations on the natural enemies of *Meligethes aeneus* (F.) and *M. viridescens* (F.) [Coleoptera: Nitidulidae]. Parasitology 50, 91–110).



Fig 3. The dissection of pollen beetle larvae, smaller larvae is *Tersilochus heterocerus*.

Cabbage seed weevil (CSW) (*Ceutorhynchus obstrictus*) parasitism rate

Methods used are combined with assessment of the pest abundance and follow the corresponding section above. The percentage of parasitism was calculated:

$$\begin{aligned} \% \text{ Parasitism} &= \frac{\sum_1^n \text{parasitoids}}{\sum_1^n \text{available hosts}} \times 100 \\ &= \frac{\sum_1^n \text{parasitoids}}{\sum_{\text{larvae}} \text{healthy} + \sum_{\text{larvae}} \text{dead} + \sum_{\text{larvae}} \text{parasitized} + \sum_{\text{parasitoid alone}} + \sum_{\text{holes}}} \times 100 \end{aligned}$$

(Kovacs et al. 2013)

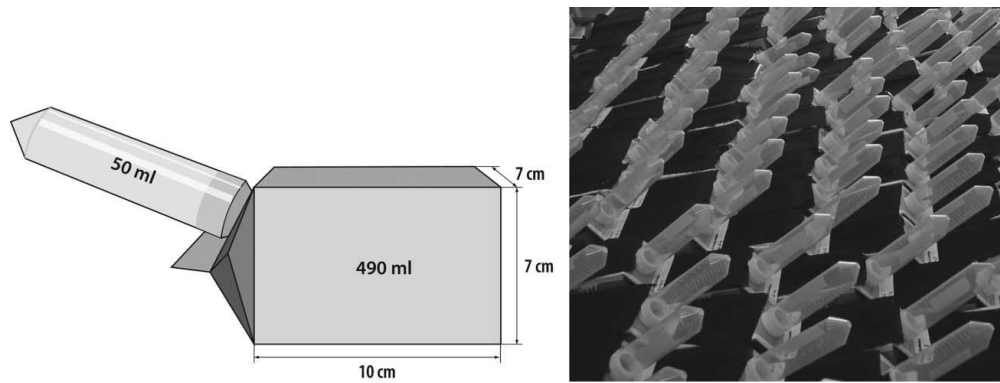

Fig. 1. Emergence traps for *Ceutorhynchus obstrictus* and its parasitoids.

We measured:

1. Amount of adult PB on plants
2. Amount of adult PB at different distances in FF-s
3. amount of dropping PB larvae,
4. amount of PB larvae in flowers,
5. different causes of mortality of PB:
 - a. parasitism by parasitoids dropped from plants (% parasitized in funnels) and,
 - b. parasitism by parasitoids on the plants (% parasitized from flower dissection),
 - c. parasitoid species attacking PB in WOSR and their species composition,
 - d. predation by ground dwelling arthropods,
 - e. mortality not due to arthropod natural enemies (soil, fungi, drought etc.),
6. amount of pods damaged by CSW,
7. parasitism rate of CSW and ist parasitoids species composition.

3.3.4.7 Wheat in Hungary

Mark Szalai and Jozsef Kiss

Cereal leaf beetles (*Oulema* spp. syn. *Lema* spp., CLB) have been selected as case study specific pests to assess biological pest control ecosystem service (ES) supported by semi natural habitats (SNHs) in Central-European (Hungarian) winter wheat fields.

We expect that the following natural enemies can deliver ES in our case study region. Egg parasitoid(s) of *Anaphes flavipes* (Anderson and Paschke, 1968; Szabolcs, 1990) and *Tetrastichus asparagi* (Jenser, 2003). Moreover, eggs can be consumed by predators such as ladybird *Adonia variegata* (Jenser, 2003), *Nabis* predatory bugs and lacewings (Szabolcs, 1990). The CLB larvae can be parasitized by several species in Hungary, the following species/genera were found in the study of Szabolcs (1990): *Necremnus leucharthros* NEES, *Tetrastichus julis* WALKER, *Lemophagus curtus* TOWNES, *Bathytrix maculatus* HELLÉN, *Itoplectis maculator* FABRICIUS, Ichneumonidae sp., *Gelis* sp., *Pteromalus vibulenus* WALKER, *Trichomalopsis microptera* LINDEMANN, *Catolaccus ater* RATZEBURG, *Pteromalus* sp.. Most egg

predators can consume larvae as well (e.g. *Nabis* bugs and lacewings); moreover, *Xysticus kochi* was also found to be CLB larva predator (Szabolcs, 1990; Kiss et al. 1994).

Consequently, we propose, that the assessment should involve EC delivered by natural enemies of both CLB eggs and larval stages. We would not choose exposing CLB eggs and/or larvae as sentinels; nevertheless, measuring the decrease of exposed individuals seems straightforward. We are afraid that the damage (and even the yield loss) response to the pest (either egg or larval) density is still not robust enough, because it can highly be depending on variety, weather and other environmental conditions. (However, we will do such assessment, see 'pest density' document). Therefore, the delivered EC can be measured as the % of leaf area damaged by CLB larvae in exclusion cages, i.e. isolated plants, compared to open plants.

Investigation steps of 2014 were as follows:

- a. collecting CLB adults in infested winter wheat fields (mainly margins) using sweep nets and aspirators (Fig 1.), 14-18 April.



Fig 1. Collecting of CLB adults, Jászdózsza, Central-Hungary, 2014

- b. release 5 adults into exclusion cages covering 5-8 wheat plants (Fig. 2 .); as assumed both males and females were introduced (proof: copulation was frequently observed)
 - plants without significant CLB adult damage or disease symptoms were selected to be caged
 - metal framed exclusion cages covered aboveground parts of the plants, and sand was used to prevent introduction of predators (and parasites) at the soil surface (Fig 3.)
 - spatial arrangement of the cages were in accordance with the WP3 scheme, as 4 distances in the transects; we used 3 transects (with 10m diff.) exposed to natural enemies + 1 transect of all time caged plants (Fig 4)
- c. after 4-7 days, cages were removed to count the eggs (Fig 5.), 18-24 April; and the 'all time caged plants' were re-caged immediately after the egg count

- d. evaluate larval damage on wheat leaves as % leaf area damaged, 26-27 May (Fig 6-7.) [We also counted the number of larvae, but it can be assumed as biased by the insecticides.]



Fig 2. Release of CLB adults into the exclusion cages, Jászdózsa, Central-Hungary, 2014



Fig. 3. Exclusion cages with sand layer at the bottom to prevent natural enemy introduction, Jászdózsa, Central-Hungary, 2014



Fig. 4. Exclusion cages in transects, Jászdózsa, Central-Hungary, 2014



Fig. 5. The CLB eggs laid on winter wheat leaves inside the cages. Isolators were removed during the egg count. Jászdózsa, Central-Hungary, 2014



Fig 6. Damaged leaves of all time **caged** plants. CLB larvae were not exposed to natural enemies.
Jászdózsa, Central-Hungary, 2014



Fig 6. Damaged leaves of **open** plants. Natural enemies occurred. Jászdózsa, Central-Hungary, 2014

References:

Anderson, R.C., Paschke, J.D. (1968): The biology and ecology of *Anaphes flavipes* (Hvm.: Mymaridae), an exotic egg parasite of the cereal leaf beetle. - *Annals of Entomological Society of America*. 61. 1. 1-5.

Jenser G. 2003: Integrált növényvédelem a kártevők ellen, Mezőgazda kiadó, Budapest

Kiss J., Kádár F., Tóth I., Kozma E. & Tóth F. 1994: Occurrence of predatory arthropods in winter wheat and in the field edge. *Ecologie*, 25 (2): 127-132.

Szabolcs, J. (1990)b: Gabonaféléken élő Lema-fajok (Col.: Chrysomelidae) morfológiája, életmódja és az ellenük való védekezés lehetőségei, Kandidátusi értekezés, Pannon Agrártudományi Egyetem, Georgikon Mezőgazdasági Kar, Növényvédelmi Intézet, Keszthely

3.3.4.8 Olive plantation in Italy

Main pest: *Bactrocera oleae* (Gmelin, 1790) Diptera Tephritidae

Team Management: Picchi M., Albertini A., Petacchi R.

Life cycle of *Bactrocera oleae*

The adult of *B.oleae* usually lays a single egg in the drupe of the olives from the end of May. The larva spends in the fruit its three stages of development, digging a tunnel in the pulp (mesocarp) and the total duration of the development takes 10-12 days in summer. When it comes in its third age the larva pupates near the exit hole or falls in the soil. The duration of the pupal stage ranges from 10 days to 4 months, depending on the time of year. The pupa is in fact a form of hibernation and remains in the soil, in the first three centimeters (Cavalloro & Del Rio, 1975) until the following spring. In Tuscany, generally, the biological cycle follows three or four generations into the olives.

We will investigate 18 Focal field, that differ in % of SNH, typology of SNH next to the focal field (woody or herbaceous) and farming intensity (conventional or organic/low impact).

3.3.4.8.1 Parasitism

In the life cycle of the fly the parasitism is related to the larval stages into the olives.

Parasitoids are, above all, wasps belonging to family Calcidoidea or Braconidae. For the assessment of the parasitism rate we will use the method described in Boccaccio & Petacchi, 2009 that has been modified for the purposes of QuESSA. We will collect 100 fruits with evident symptoms of *B. oleae* activity in each focal field, along two transects (at 10 meters of distance) from the SNH to the centroid of the olive grove at the four given distances (2m, 13m, 24m, 35m). In each distance 25 infested olives will be collect and then reared in laboratory. These olives will be stored in aerated plastic boxes under ambient laboratory conditions.

Every 2–3 days any emerged insect will be removed, keeping the olives in the lab for at least 30 days, until no further insects emerged and fruits became completely mouldy. Parasitoid specimens will be identified and counted as well as the olive fruit flies.

Parasitism will be estimated as percent parasitoid emergence (p.e.), which is calculated by dividing the total number of emerged parasitoids (p) by the sum of the number of parasitoids (p) and flies (f) (Ovruski *et al.*, 2004; Sivinski *et al.*, 1996):

$$\text{p.e.} = 100 * p / (p + f).$$

The samplings will be performed in late summer. Two replicates.

3.3.4.8.2 Predation

Predators of olive fruit flies at pupa stages are ground dwelling predators like carabid beetles or rove beetles and other generalist predators. These predators could reach the 90% as biotic mortality factors. The method that we will use follows the technique described in Orsini *et al.*, that has been modified for the purposes of QuESSA.

Evaluation of predation of pupae in soil will be done using sentinels of *B.oleae* along one transects (at 10 meters of distance) from the SNH to the centroid of the focal olive grove at the four given distances (2m, 13m, 24m, 35m). In each point, four different treatments (three conditions and the control) will be established in a randomized complete block design, in order to distinguish mortality by three sets of factors (predation, exposure to soil-borne and climate):

- Free condition: 10 pupae will be hidden at 2 cm in depth in soil in caps exposed to all biotic and abiotic conditions (top/bottom removed);
- Exclusion cages: 10 pupae in containers, excluding predators except soil-borne organisms, and abiotic condition; (bottom/top removed and covered with coarse/fine mesh)
- Total exclusion: 10 pupae in caps hidden at 2 cm depth in soil, excluding everything except abiotic conditions (top removed covered with fine mesh);
- Control treatment: 10 pupae close in caps to assess the mortality factor due to genetic defeats (bottom and top closed)



After the experimental tests the remaining pupae will be counted.
The experimental test will be placed in each focal field for 2 weeks in autumn. Two replicates.

3.3.4.8.3 Pest Density- Infestation rate

To assess pest density (infestation rate) we will use the technique applied to the monitoring network. We will collect 100 random fruits in each focal field, along two transects (at 10 meters of distance) from the SNH to the centroid of the olive grove at the four given distances (5m, 13m, 24m, 35m). In each distance 25 olives will be collected and then observed in laboratory to estimate the infestation rate. The infestation rate (i.r.) will be determined as a percentage of infested olives (i) on the sum of olives collected (f) (Quaglia et al. 1981):

$$i.r. = (i / f) * 100$$

The samplings will be done in each focal field in two periods (July and September)

References

- Cavalloro & Del Rio, 1975-Osservazioni sulla distribuzione e sopravvivenza di delle pupae di *Dacus oleae* Gmelin nel terreno- Redia 56: 167-75
- Orsini MM, Daane KM, Sime KR & Nelson EH (2007) Mortality of olive fruit fly pupae in California- Biocontrol Science and Technology 17-8: 797-807
- Ovruski SM, Schliserman P, Aluja M (2004) Indigenous parasitoids(Hymenoptera) attacking *Anastrepha fraterculus* and *Ceratitis capitata* (Diptera: Tephritidae) in native and exotic host plants in Northwestern Argentina- Biol Control 29: 43-57
- Quaglia F, Malfatti P, Papparatti B (1981) Modalità diverse per la valutazione dell'infestazione dacica. Esame preliminare dei risultati ottenuti nella sperimentazione condotta nel 1980 in Toscana. Frustula entomologica IV(XVII): 343-356

Sivinski JM, Calkins CO, Baranowski R, Harris D, Brambila J, Diaz J, Burns RE, Holler T, Dodson G (1996) Suppression of a Caribbean fruit fly (*Anastrepha suspensa* (Loew) Diptera: Tephritidae) population through augmented releases of the parasitoid *Diachasmimorpha longicaudata* (Ashmead) (Hymenoptera: Braconidae)- Biol Control 6:177–185

3.3.5 Measuring pollination services and service providers to target crops

James Cresswell, University of Exeter

Adapted by Agustín Bartual, Bart Heijne, John Holland, Sonja Pfister, Camilla Moonen, Simone Marini, Daniele Antichi, Barbara Smith, Mark Szalai, Eve Veromann and Matthias Albrecht

Compiled by Matthias Albrecht

Below, we present protocols for addressing a series of key questions regarding pollination services to target crops. Each step of the protocol yields the value of one or more response variable(s) that can be tested in an over-arching analysis across case studies. Case studies (CS) are:

- Pear pollination in The Netherlands
- Pumpkin pollination in Germany
- Sunflower pollination in Italy
- Sunflower pollination in Hungary
- Winter oilseed rape (OSR) pollination in the UK
- OSR pollination in Estonia
- OSR pollination in Switzerland

The questions are ordered by level of importance as follows:

1. What is the level of insect pollination and what does it contribute to crop yield?

[~James' protocol: 2. How much pollen are the flowers of my crop receiving? 5. Is my crop insect-pollinated?]

2. What is the level of pollination service deficiency and what are the consequences on yield?

(~James' protocol: 1. Is my crop receiving a deficient pollination service?)

3. What rate of visits are the flowers of my crop receiving from different pollinator groups?

(=James' protocol: What rate of pollinator visits are the flowers of my crop receiving from a particular bee?)

4. How efficient are different pollinator groups or species in terms of pollen deposition rate?

(=James' protocol: 3. How much pollen are the flowers of my crop receiving from a particular bee?)

General design

Where?

To address questions 1 and 3, measurements will be taken in all 18 landscape sectors at the same 4 distances in the focal crop field where also the other ecosystem services (e.g. predation) will be measured. Number of measurements per distance may vary across types of methods (e.g. no. of bagged plants, no. of plant observed to assess pollinator visitation rate) and CS, but all measurements that will be taken in all 18 landscape sectors at each of the 4 within focal field distances. The algorithm determining distances (fixed within CS) is described in general design protocol.

To address question 2, supplemental hand pollination will be performed also in all 18 LS and all 4 distances in winter oilseed rape CS (EE,UK,CH) pear (NL) and sunflower (IT, HU). In pumpkin (DE) different pollen quantities will be applied to model the relationship between pollen load and seed set/yield.)

Measurements to address question 4 can be taken in one or more fields (not necessarily focal fields), without any restrictions regarding distances within focal fields, variety etc.

When?

Measurements for questions 1-3 have to be taken in 2014 and (as planned so far) also in 2015.

Measurements for question 4 can be taken in 2014 and/or 2015..

General measurements to be taken by all CS partners (not included in the point by point protocols below):

- **Mapping of mass flowering crops** (per crop type) in each landscape sector (1 km radius, see mapping protocol).
- **Flower abundance of non-crop flowering species** within 2 plots (each 1 x 5 m, , therefore 10 m² at each distance (= 40m² per field) same methodology as described in WP2 protocol as for flower abundance sampling) **within each focal field**; the long sides of the plots should be parallel to the adjacent SNH; If a CS partner feels that a larger area is necessary to get a reliable estimate of flower abundance, two 2 x 5 m plots can be sampled per distance instead; (At least) two sampling rounds: one during flowering time of the crop (optional: if flowering time of the crop is long better more than once) and one sampling round 2-4 weeks before the start of the flowering period of the crop (to test Please do this also in case you expect hardly no flowering plants in your CS focal fields, as it provides important information for the overarching analysis.
- **Flower abundance** of each flowering species within 10 plots (1m²) at the edge and 10 plots in the interior **of each adjacent SNH** (2 SNH types, 6 LS each)and non-SNH control field (6 LS) (same protocol as WP2 flower abundance sampling) at during two sampling rounds:1) during the flowering period of the crop: 2) 2-4 weeks before the start of the flowering period of the crop. The sampling of the non-SNH control field adjacent to the focal field should always be done within the crop field. If ditches, grassy strips, roads or so are between focal field and adjacent field they are ignored and not sampled.
- **Functional vegetation sampling** (according to the protocol of WP2) of the adjacent SNH (2 SNH types, 6 LS each) and non-SNH control field (6 LS). The sampling of the non-SNH control field is important to be able compare the SNH data to that of the non-SNH control. This data will be key to be able directly link traits with services, pests and services providers measured in adjacent focal fields, not only with respect to pollination but also pest control and other services.

- **Crop variety** of each focal field
- **Crop growth stage/flowering phenology** when fields are visited
- **Density** (no. of plants per standardized area, e.g. per square-meter) can have strong implications for crop yield. To save time, this could be done in the plots in which flower abundance of flowering plants will be measured (see above). In each of the 1x5m plots this could be done in 1x1m plots (OSR) or larger areas if more adequate to give robust estimates of crop plant density per area of your crop species.

Optional measurements:

- **Pan trapping** to sample pollinators within fields (one pan trap/set of pan trap at each distance) and in adjacent SNH (2 SNH types, 6 LS each) and non-SNH control field (6 LS) according to the pan trap protocol of WP2. If CS partners cannot do the four pan traps per field, establishing at least one pan trap (yellow, at the most central= largest distance from adjacent habitat of the four distances) should be established.
- IT: we will sample pollinator biodiversity using specialized transect walks in SNH and focal field. It will be done just in two (or three) Landscapes due the amount of work (an entire day of sampling in each LS, once a month).
- IT: we will set also nest-traps for cavity nesters.

If things do not work as planned (of course won't happen ;-)):

We all know that the planned research for 2014 is ambitious and work load will be high. Should things not work as planned (e.g. exceptionally long periods of bad weather etc.) we might have to see whether we have to skip something. If this should happen it will be crucial that all planned changes will be discussed early enough with all pollination CS partners and/or the WP and project leader in order to avoid that different CS partners will skip uncoordinated different things and in the end an overarching analysis of the data will be very difficult. So please inform John and us about your plans before skipping things from the protocol.

1. What is the level of insect pollination and what does it contribute to crop yield?

General:

In all CS flowers of the focal crop will receive two treatments: open pollination and bagging (in the pumpkin CS bagging is not required, since pumpkin is monoecious). Different plants will be randomly assigned to the different treatments to avoid inferences among treatments (e.g. through resource allocation, Zimmerman and Pyke 1988). Mesh size of bags to prevent pollinators from flower visitation must at least 1mm to avoid/reduce potential effects on wind pollination (e.g. Sacchi & Price 1988). Fabric of bags may vary across CS but should have minimal effects on microclimate within bags. All partners have to make sure that bagged flowers do not touch bags at any time.

In order to get as reliable estimates of yield under open pollination of focal fields ≥ 32 plants per field (i.e. ≥ 8 plants per distance) will be sampled. In pumpkin, we will sample yield per area (20 m² per distance).

All CS partners studying sunflower or OSR will measure seed weight and oil content of seeds in addition to fruit and seed set (OSR) or seed set (sunflower). Oil content will be analysed following the protocol provided by SSSA:

FOSS Infratec 1241 [see attached brochure in the mail; for analysing oil content of sunflower, an additional specific module is needed: Flour Sample Cup Pathlength 2/1.5 mm, 4/set (page 9 of italian's brochure). You can find much more info at their site <http://www.foss.dk/>]. Or a similar device will be used for oil content analysis. When using FOSS Infratec 1241, 10 -15 gr of seeds for each analysis. Oil content and fraction has to be analysed within 4 weeks after harvest. If possible, oil content and fraction will be analysed for each flower head and OSR plant separately. Otherwise seeds may be pooled across flower heads/plants at the distance ("plot" id level = field x distance = 18 x 4 = 72 pooled samples) level, or if not possible on the distance level, on the field level. Each OSR and sunflower CS organizes oil content analysis independently (no centralized analysis).

Pear NL:

Open pollination: flowers of 15 spur branches will be marked and labelled at each of the 4 distances (18 LS).

Bagging of flower heads: 15 spur branches with flowers of pear will be bagged to exclude insect pollination at each of the 4 distances (18 LS).

What is measured?

- Fruit set
- Seed set

Pumpkin DE:

To determine the rate of pollen delivery by the collective pollinator fauna, obtain a cohort of senescent flowers, collect their stigmas. Stigmas should be harvested in the afternoon, when pollination of that day has finished.

Back at the lab, make a squash preparation of each stigma (see below) and count the number of pollen grains, denoted G_{total} .

12 stigmas per distance (4 stigmas x 3 sampling dates x 4 distances = 48 stigmas per field per visit).

Relationship between pollen deposition and yield (seed set)

2014 testing how many replicates are necessary, how similar pollen loads can be achieved

Protocol:

A female *C. maxima* flower contains ~600 ovules. Cucurbita flowers have a particularly high pollen demand: 4.3 pollen grains are necessary to produce one mature seed (*C. foetidissima*; Winsor et al. 2000). Hence for full seed set (*C. maxima*: 579 seeds, Walters und Taylor 2006, 555 seeds in previous tests, Pfister 2012) and pollen competition more than 2500 pollen grains need to be deposited.

The number of replicates will be calculated using the data of the pretest 2014. Thus that the number of replicates is enough to get a precision of 10% with a 95% confidence interval.

The day before the experiment x female and x male flowers will be randomly selected and bagged before the anthesis (full opening of the flowers) with synthetic mesh bag (mesh size = 8×8 threads/ $\text{cm}^2 \sim 1 \text{ mm}^2$) to prevent visits by bees and other insects. The pollen of the bagged male flowers will be used to pollinate the bagged female flowers. Each anther contains $\sim 37,000$ pollen grains ($n=8$) and has a length of 15 mm (range 13- 17 mm, $n= 23$) (fig. 3.1).

It is not necessary to use pollen grains from different plants, as it has been shown that this is not influencing the seed set (Ashworth & Galetto 2001).

Five different pollen loads are planned:

1) Very low (deficient) pollen load

Rub the anthers over a black surface, count 50 pollen grains and transfer them to the stigma. Cucurbita pollen grains are quite large ($80\text{-}150 \mu\text{m}$, Hurd et al. 1971) and can be count with a mobile loupe.

2) Low (but maybe sufficient) pollen load

The anthers will be divided two times vertically and then a 1mm long piece of one of the resulting 4 anther pieces [should contain ~ 500 pollen grains) will be taken to transfer the pollen on the stigma.

3) Medium pollen load (5000 pollen grains)

Divide the anthers once vertically and then take a 4 mm long piece to transfer the pollen on the stigma. This is a pollen load a single bumblebee can transfer.

4) high pollen load (1 anther ~ 37000 pollen grains)

5) very high pollen load (anthers of 5 male flowers ~ 185000 pollen grains)

same load that was used for pollen limitation experiments in 2012 (fig 3.2)

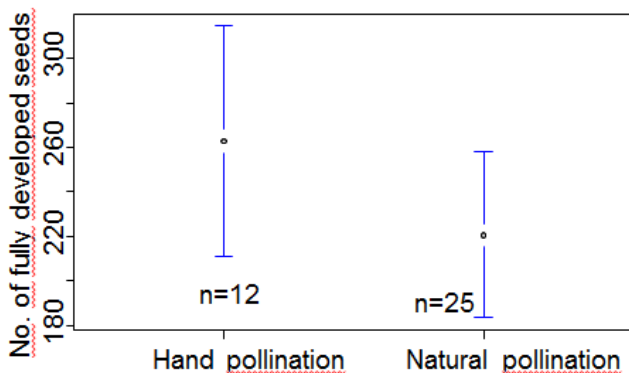

Fig. 2 set of fully developed seeds in different pollination treatments (at 8:00, natural and hand pollination). Hand pollination with $\sim 185,000$ pollen grains (at least at 8:00) resulted in very highly variable amount of fertile seeds (mean 262 ± 81 fertile seeds).

4-6 weeks after the pollination the fruits will be harvested. For these pumpkins the weight and the amount of fully developed seeds will be documented.

Further fruit abortion will be recorded. This will very likely happen to a large amount (Pfister 2012: 81%, others between 10- 88%: Tepedino 1981, Winsor et al. 1987, Stephenson et al. 1988, Ashworth und

Galetto 2001, Nicodemo et al. 2009, Cavanagh et al. 2010, Serra und O'Campos 2010). Especially at the low pollen load samples (Winsor et al. 1987).

Sunflower IT

Open pollination: Mark 8 flower heads at each of the 4 distances (32 per field-576 per CS).

Bagging of flower heads: 2 flower heads at each of the 4 distances (8 per field- 144 per CS).

What is measured?

- Number of fertile seeds and rate of fertile/total seeds per flower head.
- 1000 seed weight per flower head
- Oil content and fraction per flower head (only from fertile seeds).
Measuring device: FOSS infratec 1241 + module Flour Sample Cup Pathlength 2/1.5 mm, 4/set.
<http://www.foss.dk/>

We estimate that for preparing and analysing 864 samples we will need about 2 weeks (assuming 5 minutes per sample).

All measures will allow then to compare open pollination levels with the two reference levels (bagged plants and hand pollinated plants). In fact our response variables will be increments instead of these absolute values. Otherwise it would not be possible to compare different Focal Fields with different cultivars, soil conditions, etc.

Density (no. of plants per standardized area) will be measured at each distance in 2 plots (as we do 2 transects this means at each blue point). Plot size will be 2 x 1 m (2m²) with its long side parallel to planting rows.

Sunflower HU

Open pollination: Six heads at each of the 4 distances in each of the two transects (48 per field, 864 per CS). This is an uninfested subset of the sunflower heads selected for assessing pollinator visiting rate (see Q3 below): .

Bagging of sunflower heads: 2 heads at each of the 4 distances in each of the two transects (16 per field, 288 per CS).

What is measured?

- Number of fertile seeds and rate of fertile and total seeds per head.
- 1000 seed weight per head for both fertile and total seed set
- Yield (can be calculated from measurements of the two previous points)
- Oil content and fraction of fertile seeds on head level (only from a subsample of the collected heads: 6 head samples at each distance (2 bagged + 4 open), 432 heads in the CS).

All measures will allow then to compare open pollination levels with the two reference levels (bagged plants and hand pollinated plants, see Q2 below). The response variables will be increments instead of these absolute values.

Sunflower density is assessed by measuring number of sunflower plants along 10m long row transects. Then plant density can be calculated using the standard row width of the fields.

OSR UK:

This will be carried out at the same time as the inflorescences are bagged. Select and tag (see below) 15 plants (other than bagged or hand pollinated ones, outside the tents) per distance and field (60 plants per field). The inflorescence of the main shoot and the inflorescence of 1 randomly selected side branch will be marked at the same time as the bagging and hand pollination treatments are applied to other plants in the focal field (to guarantee that treatments are applied during the same flowering time and to inflorescences having the same “spatial position” within plants across treatments). The reason why we select main and side shoots is that they have been found to differ in yield parameters (e.g. Zajac et al 2011) and we are interested in comparing potential differences in importance of insect pollination between main shoots and side branches. When fruiting is complete, but before ripe pods will start to split and disperse seeds, the marked inflorescences and the entire remaining above-ground part of tagged plants will be collected (separately), put into paper bags, labeled and dried in an oven at 45 °C. The following variables will be measured in the lab/calculated per shoot (main and all side shoots) and per plant:

- No. of pods containing seeds (per plant, total pods, total stalks?)
- No. of parthenocarpic (seedless) pods (per plant, total pods, total stalks?)
- No. of blind stalks* (per plant, total stalks)
- Mean no. of seeds per pod and per plant
- 1,000 seed weight (g), Seed weight per plant(g)
- Oil content (%) if possible

*If possible assign blind stalks to two causes: i) pollen beetle damage, ii) unsuitable climatic/nutrient conditions (looks slightly different, see picture below)



Black arrows: blind stalks due to pollen beetle damage, white arrows: blind stalks due to long periods of droughts, frost or severe nutrients deficiency. However, if this more detailed classification of blind stalks

is not possible, blind stalks (without further differentiation) should be a rather good proxy for pollen leave damage.

Bagging treatment: At the same time as the open pollination tagging is carried out (see above). Bags will be put into the field, these will be 'tents' and cover at least four plants (see picture below). We assume that pollen beetle will already be present in the tent and that to some extent 'wind' pollination or a mimic of it will occur within the tent. Two of the plants will be assigned to the bagging treatment, the apical inflorescence (main stem) and a side shoot will be tagged

- No. of pods containing seeds (per total pods, total stalks?)
- No. of parthenocarpic (seedless) pods (per total pods, total stalks?)
- No. of blind stalks* per total stalks
- Mean no. of seeds per pod
- 1,000 seed weight (g)?, Mean seed weight per pod (g)
- Oil content (%)

Collect stigma of 1 senescent flower of a "main" inflorescence and a "side" inflorescence of 2 randomly selected plants of each distance and each of 18 fields (144 stigmas). Samples will be frozen until further treatment after the field season.

After field season, make a squash preparation of each stigma (see above) and count the number of pollen grains, denoted G_{total} . If measuring stigmatic pollen, harvest the stigma when the flower senesces. In oilseed rape, I collect the entire pistil and keep it in a small Eppendorf. To count stigmatic pollen in oilseed rape, I make a squash preparation as follows. Excise the stigmatic surface with a blade and place it in a drop of 8 M NaOH on a slide and add a cover slip. Place the slide on a hot plate heater that is just uncomfortable to your hand and leave for about 10 minutes (add more NaOH under the cover slip if there is any sign of crystallization). Press the coverslip to squash the stigmatic tissue and then count pollen grains under a microscope (N.B. do not get the NaOH on the objective lens because it will ruin it).

OSR EE:

Yield

2 m² plot of plants (undisturbed by other experiments) per plot at 4 distances per field in all 18 fields were collected, dried and all seeds were cleaned out. Seeds per plot were weighed and the moisture content was measured. From all these samples the 1000 seed mass was measured.

We marked 15 plants in similar growth stages at each of the 4 distances in all 18 LS. We collected 10 main and side shoot from all these plants and counted:

- No. of pods containing seeds (per plant, total pods, total stalks?)
- No. of parthenocarpic (seedless) pods (per plant, total pods, total stalks?)
- No. of blind stalks* (per plant, total stalks) We collected 4 pods from main shoot and 4 pods from side shoot and counted mean no. of seeds per 4 pod and total mass of seeds per 4 pod

Bagging of flowers:

We used 40x25 cm bags from shading cloth. For bagging to measure the benefit of pollination we selected 2 plants per distance at 4 distances in all 18 LS before flowering. We adjusted the height of the bags if needed. At BBCH 81-83 we collected main and side shoot and counted:

- No. of pods containing seeds (per total pods, total stalks?)
- No. of parthenocarpic (seedless) pods (per total pods, total stalks?)
- No. of blind stalks* per total stalks
- Mean no. of seeds per pod
- 1,000 seed weight (g)?, Mean seed weight per pod (g)
- Oil content (%)

We collected stigma of 1 senescent flower of a “main” inflorescence and a “side” inflorescence of 2 randomly selected plants of each distance and each of 18 fields (144 stigmas). Samples are frozen until further treatment after the field season.

After field season, make a squash preparation of each stigma (see above) and count the number of pollen grains, denoted G_{total} . If measuring stigmatic pollen, harvest the stigma when the flower senesces. In oilseed rape, I collect the entire pistil and keep it in a small Eppendorf. To count stigmatic pollen in oilseed rape, I make a squash preparation as follows. Excise the stigmatic surface with a blade and place it in a drop of 8 M NaOH on a slide and add a cover slip. Place the slide on a hot plate heater that is just uncomfortable to your hand and leave for about 10 minutes (add more NaOH under the cover slip if there is any sign of crystallization). Press the coverslip to squash the stigmatic tissue and then count pollen grains under a microscope (N.B. do not get the NaOH on the objective lens because it will ruin it).

OSR CH:

The same variety in all OSR focal fields will be used.

Open pollination treatment: At the same time as inflorescences will be bagged and marked (see below) 15 plants (others than bagged or hand pollinated ones) per distance and field (60 plants per field) will be randomly selected and tagged, and the inflorescence of the main shoot and the inflorescence of 1 randomly selected side branch will be marked at the same time the bagging and hand pollination treatments are applied to other plants in the focal field (to guarantee that treatments are applied during the same flowering time and to inflorescences having the same “spatial position” within plants across treatments). The reason why we select main and side shoots is that they have been found to differ in yield parameters (e.g. Zajac et al 2011) and we are interested in comparing potential differences in importance of insect pollination between main shoots and side branches. When fruiting will be complete, but before ripe pods will start to split and disperse seeds marked inflorescences and the entire remaining above-ground part of tagged plants will be collected (separately), put into paper bags, labeled and dried in an oven at 45 °C. The following variables will be measured in the lab/calculated per shoot (main and all side shoots) and per plant:

What is measured?

- No. of pods containing seeds (per plant, total pods, total stalks?)
- No. of parthenocarpic (seedless) pods (per plant, total pods, total stalks?)
- No. of blind stalks* (per plant, total stalks)

- Mean no. of seeds per pod and per plant
- 1,000 seed weight (g), Seed weight per plant(g)
- Oil content (%)

To determine seed variables plants will be threshed. Seed counters will be used.

Bagging treatment: Randomly select and mark 2 plants at each of the 4 within-field distances (8 plants per field, 144 plants in total) and bag 2 inflorescences per plant, 1 apical inflorescence (main shoot), 1 lower inflorescence from a side shoot in the bud stage shortly before flowering (288 bags). Large bags (15 x 40 cm? [slightly larger than those used by Bommarco et al. 2012]) that allow for inflorescences to grow after bagging without touching bags. Additionally, we will use simple constructions of light wire inside bags to avoid that flowers touch bags (connected upper and lower ring). Upper and lower boundary of “zone” of flowers that are open will be marked prior to bagging with a non-toxic, permanent marker (???) Company). Bags will be removed as soon as marked flowers have wilted.

What is measured?

- No. of pods containing seeds (per total pods, total stalks?)
- No. of parthenocarpic (seedless) pods (per total pods, total stalks?)
- No. of blind stalks* per total stalks
- Mean no. of seeds per pod
- 1,000 seed weight (g)?, Mean seed weight per pod (g)
- Oil content (%)

Collect stigma of 1 senescent flower of a “main” inflorescence and a “side” inflorescence of 2 randomly selected plants of each distance and each of 18 fields (144 stigmas). Samples will be frozen until further treatment after the field season.

After field season, make a squash preparation of each stigma (see above) and count the number of pollen grains, denoted G_{total} . If measuring stigmatic pollen, harvest the stigma when the flower senesces. In oilseed rape, I collect the entire pistil and keep it in a small Eppendorf. To count stigmatic pollen in oilseed rape, I make a squash preparation as follows. Excise the stigmatic surface with a blade and place it in a drop of 8 M NaOH on a slide and add a cover slip. Place the slide on a hot plate heater that is just uncomfortable to your hand and leave for about 10 minutes (add more NaOH under the cover slip if there is any sign of crystallization). Press the coverslip to squash the stigmatic tissue and then count pollen grains under a microscope (N.B. do not get the NaOH on the objective lens because it will ruin it).

2. What is the level of pollination service deficiency and what are the consequences on yield?

General:

Objectives: The methods must assess the potential for yield gain under optimal pollination compared to the (actual) level of pollination services in each focal field and assess the consequences of potential pollination deficiency on yield.

Basic Protocol: Supplement pollen deposition on stigmas of open (not bagged) flowers and compare measures of pollination service and yield with open pollinated flowers. In pumpkin UKL is performing a pollen deposition experiment to determine pollination deficiency.

Hand pollinate flowers with pollen from a mixture of pollen from 5 randomly selected donor plants (to avoid using single males that may be unsuitable; if several pollination rounds will be performed ideally the same plants are used as donor plants across pollination rounds) (Morandin & Winston 1995).

Protocol: collect fresh pollen (< 1 h) from the flowers of donor plants using a wooden cocktail stick and store the pollen in an Eppendorf vial. To make a supplemental hand-pollination, mix the pollen with the toothpick/ cocktail stick or similar, then apply just enough pollen to saturate the stigmatic surfaces of the target flower. For the hand pollination use cocktail sticks (OSR), small paint brushes or whatever works best for your focal crop (according to the literature). Mark hand pollinated flowers with ribbons, waterproof, non-toxic permanent markers or whatever works best for your focal crop.

Supplemental hand pollination, open pollination and bagging treatments will be applied to different plants to avoid inferences among treatments (e.g. through resource allocation, Zimmerman and Pyke 1988).

Pear NL:

Supplementary hand pollination: 4 individual flowers per cluster, 5 clusters for all 4 distances per sector in all 18 sectors.

Pumpkin DE:

Included in methodology to address question 1 (see above).

Sunflower IT:

Open pollination: Same as in Question 1 (32 per FF-576 per CS)

HAND POLLINATION: 2 flower heads at each of the 4 distances (8 per focal field) = 144 per CS (18 LS).

Hand pollinate the open flowers of the *capitulum* (3 - 4 rows per visit) using the mixture of pollen from the 5 donor plants and a small paint brush. As sunflower flowers sequentially, 4-5 visits (each 2-3 days) will be needed to full hand pollinate each *capitulum*.

What will be measured? (same as in Question 1)

- Number of fertile seeds and rate of fertile/total seeds per flower head.
- 1000 seed weight per flower head
- Oil content and fraction per flower head (only from fertile seeds).

Measuring device: FOSS infratec 1241 + module Flour Sample Cup Pathlength 2/1.5 mm, 4/set.

<http://www.foss.dk/> and laboratory analyses.

Sunflower HU:

Open pollination: Same as in Question 1

HAND POLLINATION: 4 heads per focal field (= 72 per CS). Hand pollinate the open flowers of the *capitulum* (3 - 4 rows per visit) using the mixture of pollen from the 5 neighboring donor plants and a

small paint brush. As sunflower flowers sequentially, 5-6 visits – each 2 days for 1.5-2 weeks – is necessary to full hand pollinating each *capitulum*.

What will be measured? (same as in Question 1)

- Number of fertile seeds and rate of fertile and total seeds per head.
- 1000 seed weight per head for both fertile and total seed set
- Yield (can be calculated from measurements of the two previous points)
- Oil content and fraction of fertile seeds on head level

OSR UK, EE, CH:

Randomly select and tag **2** plants at each of the 4 distances and each of 18 fields (8 plants per field, 144 plants in total). Randomly select **≥4 flowers** in the receptive phase of the apical inflorescence (**main shoot**) and **≥4 flowers** of 1 lower inflorescence of a **side shoot** of each plant. Supplement pollen deposition on stigmas of open (not bagged) flowers (=supplemental hand pollination of a total of **≥8 flowers per plant**, so **≥16 flowers per distance**) and compare measures of pollination service and yield with open pollinated flowers as described above.

Hand pollination protocol: Collect anthers of several flowers of ≥ 5 neighbouring plants (just rip them off the flower) and put them into a petri dish. Then mix with a small paint brush and use the paint brush to hand pollinate focal flowers by covering focal stigmas with pollen.

What will be measured?

- No. of seeds per pod
- Mean seed weight per pod (g)
- Mean oil content (%)

If resources available: We plan to hand pollinate an additional flower of the same main and side inflorescences as above and collect stigmas (144 stigmas). Back at the lab, a squash preparation of each stigma (see above) will be made and the number of pollen grains, denoted G_{total} , counted.

3. What rate of visits are the flowers of my crop receiving from different pollinator groups?

General:

Estimate the flower lifespan, L , as above and then observe target flowers (or inflorescences) to estimate the number of visits per flower per hour, denoted V . Calculate $D = L \times V$

To determine V flower visitors will be observed for a standardized unit of flowers (plots for which the number of flowers will be recorded/estimated, a single or multiple flowers/inflorescences) using video cameras or observers record flower visits (see specific protocols below).

If possible to identify flower visitor on species (or genus) level, record species (or genus) id (e.g. *Apis mellifera*, *Bombus terrestris* (group), *B. lapidarius*, *B. ...*? *Episyrphus balteatus*, *Eristalis sp.* etc. (see list WP2 transects and add species you can identify in the field). Otherwise assign to one of following flower

visitor groups: honeybee (see before), bumblebee, other wild bee (“solitary bee”), other Hymenoptera, hoverfly, other Diptera, Lepidoptera, Coleoptera.

Pear NL:

Flower visiting insects will be counted and the visitor species group determined for 10 minutes for all 4 distances per sector in all 18 sectors, together with the number of open flowers: transects (50 meters) will be walked and number of flower visiting insects recorded. Time will be recorded to calculate walking speed, and the number of flowers present will be estimated by counting the number of flowers per ½ tree (5 times half a tree) and the number of trees per 50 m. Additionally, weather conditions will be recorded.

Pumpkin DE:

Estimate the flower lifespan, L , and then observe target flowers to estimate the number of visits per flower per hour, denoted V . Calculate $D = L \times V$

Cucurbita flowers have a short flower lifetime (6 hours – 10 hours), opening till 6.00 and closing between 13:00 and 17:00 (Ashworth & Galetto 2001, Dmitruk 2008). When the temperature exceeds 24°C, the flowers close earlier (Wyatt et al. 1992, Passarelli 2002). The most important visitors are the first ones, because pollen grains dehydrates and most pollen grains are removed early in the morning (fig. 4.1). Dehydrated pollen grains do no longer stick to the pollinators and they also lose viability (Nepi und Pacini

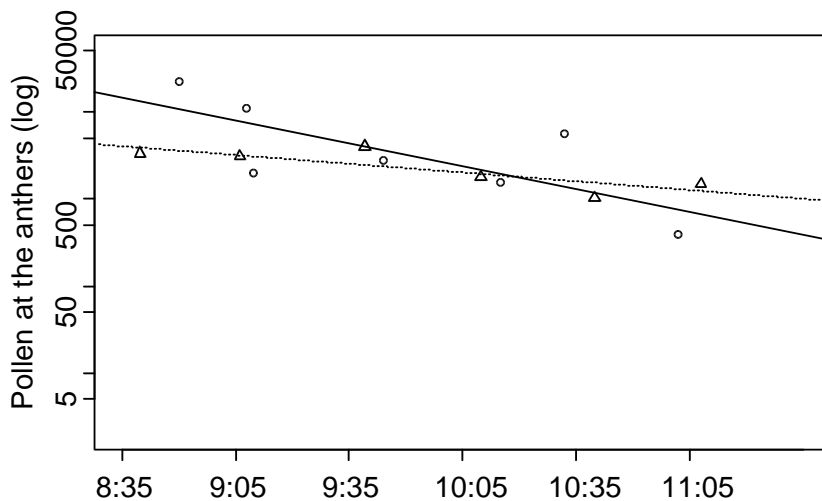

1993).

Fig 2.1 pollen at the anthers decreases during the morning (results from previous studies in 2012, S. Pfister). Male Cucurbita maxima flowers contained between 26.000 and 49.000 pollen grains (mean 37.000 ± 7.000, n = 8). Only few pollen grains remained at mid day (lowest sample ~ 1% of original content)



Flower visitors and their foraging behaviour are documented by a digital HD video camera recorder (f.e. handycam Sony® HDR-CX115E) on 4 open-pollinated flower per field. The camera is positioned ~ 50 cm above the flower in one line with the opening of the flower (fig. 4.2). Then it is zoomed to the flowers' extent.

Fig. 2.2 position of the camera

Weather conditions: we are especially interested in the less suitable weather conditions (cold, cloudy), when honey bees are not present. Thus we only want to exclude rainy conditions from our sampling.

3 different days at 3 different times: 7:00, 8:30, 10:00

sum 60-100 min/sampling necessary to record 10 bumblebees per field:

➔ 4 replicates per sampling: 4 flowers at one time minimum á 15 min?

Additional sampling in/ at all focal fields:

Weather conditions

The ambient temperature and the relative humidity are measured with a temperature/humidity logger (hydrochron iButton® DS1923 of maxim integrated), which will be placed 20 cm above ground under a white plastic cup next to one of the sampled flowers. The wind velocity at 1.5 m above the soil will be measured with an anemometer (Schalenkreuz-Anemometer PCE-A420). Further the percentage of sunshine will be estimated.

Sunflower IT:

General:

Estimate the flower lifespan, L , as above and then observe target flowers (or inflorescences) to estimate the number of visits per flower per hour, denoted V . Calculate $D = L \times V$ (note that assessing life span of flowers is not a problem, as far as we will visit fields for hand pollinate during all flowering period, so just record beginning and end of flowering time).

Sample sizes and layout per Focal Field:

This observation will be done on the previously marked open-pollinated that will be used also in questions 1 and 2. That means, 4 plants per blue point = 8 plants per distance = 32 plants and 8 different observation groups of 10 minutes each one per focal field. This issue is important to link our observations to the measured response variables.

What will be measured?

1. Weather conditions (at midpoint of the transect):
 - a. air-temperature (°C)
 - b. wind: 0-3 scale (such in WP2 transect walks)
 - c. clouds: % (such in WP2 transect walks)
2. Day and hour of each observation
3. Diameter of the heads (cm)

4. Proportion of flowers in shadow (%)
5. Number of visiting individuals in ten minutes, recording separately each head. If possible to identify flower visitor on species (or genus) level. Otherwise assign to one of following flower visitor groups: honeybee, bumblebee, other wild bee ("solitary bee"), other Hymenoptera, hoverfly, other Diptera, Lepidoptera, Coleoptera.

When?

We will work during the central part of the day, ideally from 11:00 to 15:00. This is to reduce climatic and light variation among fields. Workload: 2 fields per day = 9 days per CS.

Observations will be performed once strictly in middle phenological stage (R-5.4 - R-5.6) (40 to 60% of flowers opened) (Pinzauti & Frediani, 1985). It is important to measure visitation rate at the same phenological stage for all the heads in order to be able to compare focal fields. If time is available, this observation will be repeated on late phenological stage (R-5.7 - R-5.9). This phase presents the lowest seed set values, so could be interesting also to investigate visitation rates during it, if possible.

Sunflower HU:

Nine heads at each of the 4 distances in each of the two transects is assessed (72 per field, 1296 per CS). Three open sunflower heads at the same phenological stage, i.e. early (R5.1-2), middle (R5.5-6) and late flowering (R5.8-9), will be simultaneously observed for 10mins. And then it is repeated (within few meters) for three heads at different phenology stages. The 10mins time frame of the recording can be changed to 5 or 15mins in case of very high or low abundance of pollinators. Marking the assessed plants with coloured tapes (according to phenology) close to the head.

What will be measured?

1. Pollinator visits
 - pollinator categories used in WP2 are recorded + species identity of all bees is determined (in the lab, if identification is not possible in the field)
2. Diameter of the heads (recoded at harvest)
3. Phenology
4. Weather conditions
 - temperature: air-temperature, next to the heads
 - wind: 0-3 scale (such in WP2 transect walks)
 - clouds: % (such in WP2 transect walks)

Timing: ~ 9:00-12:30 and 15:30-18:30, excluding the hottest hours because of the low activity of pollinators.

Labour: one location (3*3 heads): ~35mins for one observer. One focal field with 4 distances and two transects.

OSR EE, UK, CH:

1. Sampling visitation rates will be assessed at 2 plots (**2x2m**, randomly selected) at each of the 4 distances in each of two sampling rounds (early vs. late flowering period). At each distance, in each field two 2.0 x 2.0m quadrat will be placed over the oilseed rape plants and the number of

flower visits during 10 min watches will be recorded within this plot. Time of day at which sampling is done during a sampling round will be randomised and recorded. If possible to identify flower visitor on species (or genus) level, record species (or genus) id (e.g. *Apis mellifera*, *Bombus terrestris* group, other *Bombus* species,.... Otherwise assign to one of following flower visitor groups: honeybee (see before), bumblebee, other wild bee (“solitary bee”), other Hymenoptera, hoverfly, other Diptera, Lepidoptera, Coleoptera.

2. Estimate number of flowers per subplot within the 2x2m plot described above: count number of flowers within a 0.5x0.5m subplot (within each 2x2m plot) which will be extrapolated to the 2x2m area.

Pan trapping

If possible: To assess diversity and species composition of the OSR flower visitor communities of our 18 focal fields two yellow pan traps (identical traps that have been used in 2013 for WP2) will be set up at each distance and field (18 fields, 4 traps per field). In adjacent SNH (and control fields) adjacent to OSR fields, white and blue pan traps will be used in addition to yellow ones (1 set interior, 1 set edge; identical design as for pan trapping of SNH in WP2; see “Other ES – biodiversity conservation” protocol). Traps will be left out for 3 days. In OSR fields, 3 rounds of pan trapping will be carried out which will also be used to sample pests and natural enemies (see OSR-specific pest control protocol).

4. How efficient are different pollinator groups or species in providing pollination services?

General:

Single visit pollination efficiency (engineered single visits to different flowers/inflorescences of different plants) of the most frequent flower visitor species (i.e. species with the highest visitation frequencies to focal crop flowers) will be measured with ≥ 10 replicates for each species (≥ 20 if groups instead of species have to be used, see below) If measurements are taken in 2015, visitation rates data of 2014 may be used to determine the “most frequent” pollinator groups (although pollinator community composition and relative frequencies of species may vary across years).

Ideally the most important species (≥ 4 species) that are well recognizable in the field belonging to several (≥ 3) of the pollinator groups defined in step 3. are used and replicated for this.

If not possible, individuals belonging to the several of the most important groups (≥ 3 groups) defined in 3. Should be used, and species identity of all pollinators used for measurements for question 4 must be determined in the lab later. (If an individual could not be collected, the pollinator group it belongs to will be recorded. Ideally (if time budget allows it), another visit will be engineered instead to achieve the minimum of replicates per pollinator group, so that for all replicates species identity of the pollinator is available)

Only pollinators should be used that have been (seen) foraging on the crop before single visits are engineered.

Calculate the mean of G (standardized pollinator efficiency measured as number of pollen grains deposited during a single visit or another direct measure of pollination service during a single visit (e.g. seed set). For an overarching analysis we probably have to standardize G (e.g. relative to highest pollination service delivered by a single visit). The expected number of pollination service the crop's flowers receive from this pollinator is DG (see estimation of D above).

Calculate pollinator importance: $G \times V$ (or $G \times D$, respectively)

Pear NL:

Will be done 2015 using the "mobile bouquet" method after recording the pollinator fauna in 2014.

Pumpkin DE:

Will be done 2015 after recording the pollinator fauna in 2014.

Pretest 2014: variability of the pollen load transported by honey bees and bumble bees to determine the necessary number of replicates for 2015, $n = 10$?

Results of 2012 - Pollinators of pumpkin and pollen removal experiment

Fig 5.1 a): pollinators of pumpkin recorded in the video sampling:

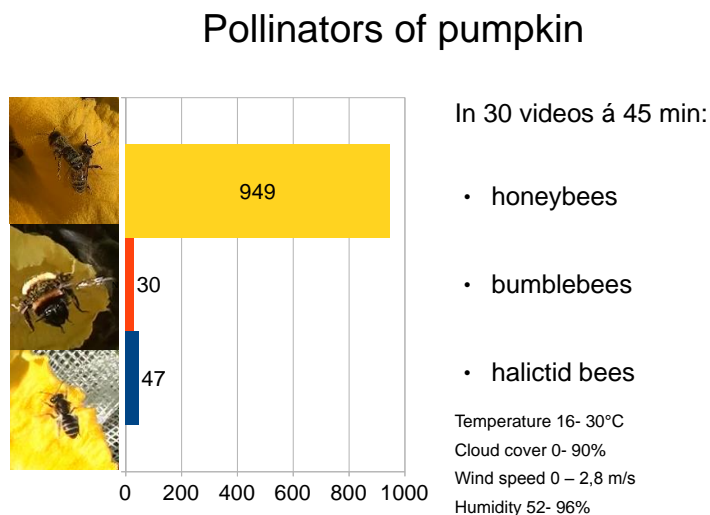

b) Pollen on the insect depending on bee species (A= *Apis mellifera*, B = *Bombus terrestris*) and available pollen amount at the anthers (b = bagged flower ~37.000 pollen grains, o = open flower down to 850 pollen grains).

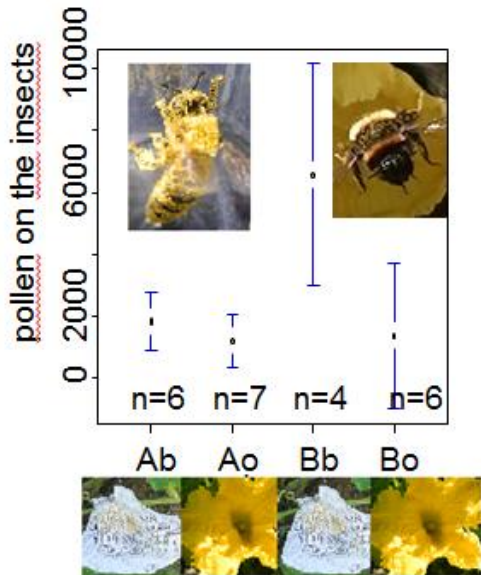

In pretests from 2012 the pollen load on the insects was very variable. Bumblebees carried between 290 – 9565 pollen grains (fig. 5.1 right). Honey bees removed between 406 – 2972 pollen grains. The variability can be further influenced by the behaviour of the bees. If there is division of work (known for honeybees and bumblebees), thus that one individual bee is only visiting male or female flowers, they will not be effective pollinators.

Sunflower IT

This will be tested in 2014 to adjust protocol for 2015.

General

We will measure the pollen extract rate (in percent over the total pollen presence) to estimate single visit pollination efficiency. This will be done for all most frequent flower visitor groups (for sunflower in Italy e.g. *Apis mellifera*, *Bombus pascuorum*, *Ceratina cucurbitina*, *Megachile* spp., *Halictus scabiosae*).

Sample sizes and layout:

We will work in just one experimental field.

We will bag at least 5 flower heads in the evening and we will register the phenological stage. The next day we will confront the stage and we will assess the pool of newly opened rings of flowers. The flower heads will be exposed to pollinators one by one. First of all we will collect 3 different newly opened flowers from the flower head, and we will store them separately in Eppendorfs. The flowers will be chosen randomly from the pool. Then we will wait for a pollinator to land. We will register the flowers visited and we will collect the flowers manipulated storing them in an Eppendorf. In laboratory we will perform squash preparation or Scanning Electron Microscope (SEM) observations.

We will sample at least 8 flowers per species of pollinator.

What will be measured?

1. Weather conditions (at midpoint of the transect):
 - a. air-temperature (°C)
 - b. wind: 0-3 scale (such in WP2 transect walks)
 - c. clouds: % (such in WP2 transect walks)
2. Day and hour of each observation
3. Diameter of the heads (cm)
4. Proportion of flowers in shadow (%).
5. Phenological stage at the moment of bagging and at the moment of observation, taking care to record all the flower stage: closed, open but with anthers closed, with anthers open, with stigma outside.
6. Position of the flower visited by the pollinator and collected
7. Behavior of the pollinator (pollen/nectar collecting) (parts of the flowers touched).
8. In laboratory:
 - a. number of pollen grains present (with squash preparations)
 - b. for not visited anthers: shape and number of pollen grains ready to be taken away
 - c. For visited anthers: shape and consistency of anthers break (if any) and pollen still present (using SEM)

When?

We will work mainly during the morning until the bagged flower heads will be over. The best moment to have a good species number could be the peak of bloom, and this experiment will take as much time as the pollinators will require. The time needed to have all the samples is really hard to predict, probably we will spend 5-6 days on this issue.

Sunflower HU:

We have started this last year (2013), here are the methods.

Pollination service of *Apis mellifera*, *Bombus terrestris*, *B. lapidarius* and 'other bees' with the size of *A. mellifera* was assessed at early (R5.1-2), middle (R5.5-6) and late flowering (R5.8-9) of sunflower. And it was also compared to two types of control as open pollinated plants and all-time isolated (bagged) plants. Setup: 20 plants/heads in each group totalled in $(4*3+2)*20=280$ plants. The pollinators were collected on open sunflower plants (studied plants or plants next to our experiment) during flowering assuming their body is carrying enough pollen for pollination. Then the pollinators were introduced to the isolated heads (1pollinator / head). Exposure time was 15 mins.

Evaluation of Q3 (seed set): Each head was hand harvested, and then cut into four sectors (~quadrants). The number of fertile and infertile seeds in the 8 available radii was counted, and the place of the infertile seeds was also recorded.

OSR UK:

Most important pollinator species (groups) will be identified in 2014. The "mobile bouquet" method will be used in 2015. In 2 fields with replication for each pollinator species.

OSR EE:

Most important pollinator species (groups) were identified in 2014. The “mobile bouquet” method will be used in 2015..

OSR CH:

These measurements will be done only in 1 or 2 fields only field(s) with high density/ diversity of OSR flower visitors in 2014 and/or 2015, depending on the available amount of time and resources.

Flowers of caged plants will be used and single visits by a bee using the ‘mobile bouquet’ technique: Take the flower to the pollinator (while it is foraging on the crop) at the end of a 0.5 m cane. Obtain the stigma by excising the pistil and storing in an Eppendorf vial. Back at the lab, make a squash preparation (see above) and count the number of pollen grains, denoted G.

Replicate ≥ 8 times for most commonly observed pollinator species visiting OSR (to be determined during field work 2014).

3.4 Other ecosystem services

3.4.1 Soil fertility and organic matter

By Barbara Simon and Walter Rossing

Aim

To measure **soil organic matter content** of the soils of focal fields (FF) and semi natural habitats (SNHs) to provide a comparative assessment of the water and nutrient holding and nutrient providing capacity.

Protocol

I. Soil sampling

1. Composite samples will be taken from all types of SNHs and from focal fields.
2. Composite samples will consist of 20 subsamples, they will be taken by push probe (or spade), then mixed in a bucket thoroughly, and about 0.5-1.0 kg of soil sample will be taken to the laboratory. (This amount of soil is convenient to have in the laboratory in case further soil chemical or physical parameters are planned to be determined.) Thus, there will be one composite soil sample from the FF and one from each SNH.
3. The arrangement of the subsample design will have an X-shape on both types of fields (if possible) (*Figure 1*).
4. The depth of sampling will be 0-30 cm (plough layer) (if possible).
5. Sampling time: once a year (eg. autumn, when soils are easily sampled due to soil wetness).

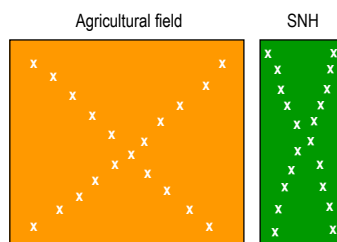

Figure 1. Sampling arrangement of subsamples

II. Laboratory analyses of soil samples

1. The **soil organic carbon (SOC%)** determination can be carried out by different methods that should be agreed among partners beforehand, otherwise the obtained results will not be comparable and correction factors should be applied.
2. The suggested method of determination: dry combustion method by Carbon/Nitrogen analyzer,
3. By utilizing the Carbon/Nitrogen analyzer, we would be able to obtain the **total C** and the **total N content** of our soil samples at the same time.
4. **Final obtained and calculated data:**

- a. total carbon content (TC%) (knowing the CaCO₃ content of the soil, the soil organic carbon content {SOC%} can be calculated),
- b. total nitrogen content (TN%),
- c. C : N ratio,
- d. from SOC% content the soil organic matter (SOM%) can be calculated (SOM% = SOC% x 1.72), since the average carbon content of SOM is 58%.
- e. in combination with %clay and silt, and approximation of potential water holding capacity can be made.

3.4.2 Erosion

By John Holland, Walter Rossing, Eve Veromann

3.4.2.1 Background and aim

Reduction of soil erosion is an ecosystem service that is rapidly gaining interest in the scientific and policy communities in response to the appreciably greater intensity of precipitation in recent years. Where fields can better absorb moisture, e.g. through soil cover, greater soil organic matter levels and semi-natural habitats that reduce the intensity of water runoff, the amount of water ending up in rivers and causing excess downstream is less. In the QUESSA project reduction of soil erosion was identified as an ecosystem service that is in demand by society by the teams from Estonia, France and the UK.

The purpose of sampling soil sedimentation by water erosion in QUESSA is to obtain a comparative assessment of the capacity of different types of SNH (types 1-5) to reduce soil erosion.

The protocol that follows is based on literature (Owens et al., 2007) and recommendations by Dr. J. Duzant to John Holland and Dr. S. Keesstra to Walter Rossing. It was refined by discussion during the QUESSA meeting Landau, January 2014.

3.4.2.2 Research question, case study and hypotheses

The measurements are designed to answer the research question: How much soil displaced by water erosion is caught by semi-natural habitat types 1-5?

The measurements will be carried out in Estonia (focal field: oilseed rape), France (focal field: vineyards) and UK (focal field: winter wheat). The types of SNH 1-4 will depend on the actual case study.

Hypotheses:

- Perennial SNH retain a greater amount of soil per unit width and unit soil cover than annual SNH.
- SNH1-4 have a greater effect on soil retention than a green manure crop (SNH5) per unit width and unit soil cover.

3.4.2.3 Protocol

1. Astroturf mats having grass-like features (as opposed to carpet-like features) obtained from a garden centre are cut to 35x25 cm and installed (1) on upslope and downslope sides of SNH1-4; (2) inside the focal field; and (3) inside a field resembling the focal field in terms of crop, slope and aspect, but without a green manure crop (see Figure).

2. At each location 5 mats are installed up-slope and 5 mats down-slope. The total number of mats is equal to: number of sites x 10 x 2. The factor 2 enables replacing mats by new ones when they are collected. Spread out the mats in space, leaving 10-20m between them to sample different parts of the contributing area and to allow the measurements to be called 'independent'. Make sure the mats receive water and soil from representative parts of vegetation upslope from them, so avoid placing them below tracts of preferential water flow.
3. Mats should be installed flush with the surrounding soil surface by removing vegetation. It may be useful to pin them to the soil by e.g. two tent pegs. Place the mats at the upslope leading edge and at the downslope edge of the SNH. For SNH type 5 (green manures) mats are placed at upslope and downslope locations of the focal field about 50 m apart with the green manure and at similar locations in a nearby reference field with similar crop (after the cropping season: fallow), slope en aspect. See Figure for SNH types 1-4 and type 5.
4. Map the layout of the site and the location of the mats. Distances between mats are important.
5. Inspect mats either monthly or after major rainfall events and replace mats that have clearly captured soil. It is important not to let the mats get saturated as soil may be lost. Mats in SNH type 5 (Green manures) should be installed and removed concomitantly with the green manure.
6. Transport mats in plastic bags (wipe the lower side of the mats: only soil collected within the mats should be measured).

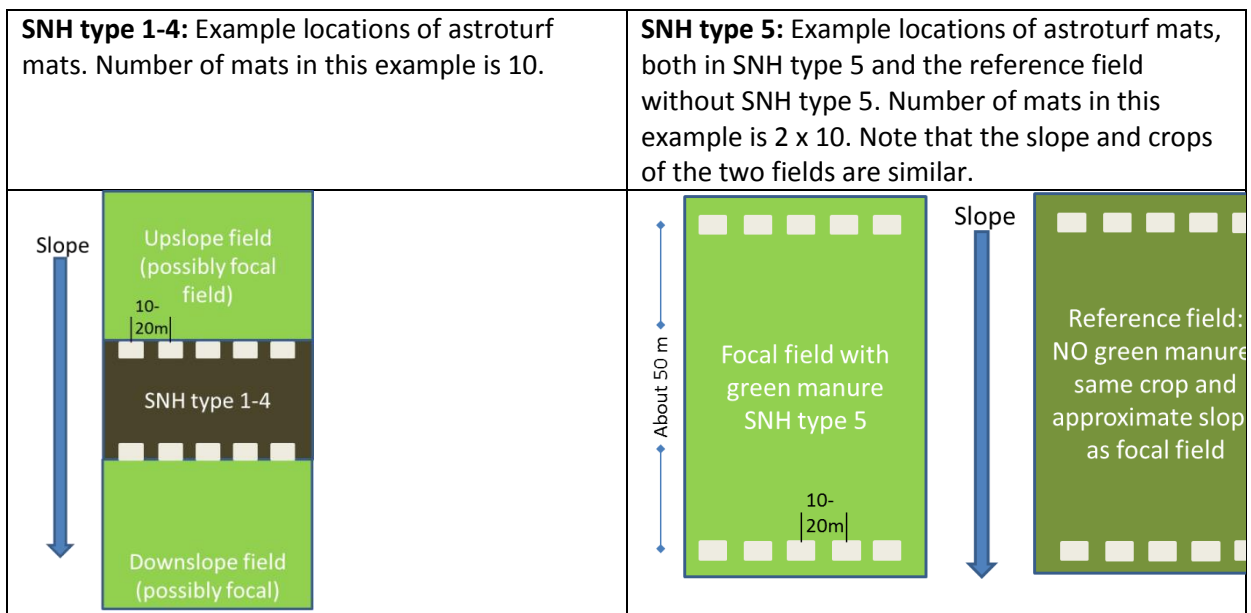

7. In the laboratory, dry the mats at room temperature for at least 48h and shake out the soil. Weigh the soil collected by each mat and record.
8. Once (using 10 replicates): Determine extraction efficiency of the mats by applying a known amount of soil, dissolved in a bit of water to the mats and recover soil according to the specifications selected under 7.
9. Sampling is continued for a full year, as the RUSLE or BUFFERS models also provides annual estimates. If possible measurements are continued for full 2 years. In the case of green manures

(SNH type 5), which leave the field after 3-5 months measurements are continued in the crop to see after-effects. The crop in the Reference field should be the same as the crop in the Focal Field.

10. Data may be summarized in a table as follows:

Site	Number of mats installed	Sediment deposition (g cm ⁻²)					etc
		Feb-May 2014	May-July 2014	July-Sept 2014	Sept-Dec 2014	Jan-Mar 2015	
1							
2							
3							

11. Additional data needed for analysis:

- Rainfall records. Best are measurements on-site; second best local weather station.
- Slope of the fields used for measurements in SNH5.
- Qualitative description of type and amount of soil cover at each sampling occasion.
- Vertical pictures of 5 locations of the area between the up-slope and down-slope mat locations to later assess soil cover quantitatively (may also be part of other ES measurements).
- Width of the SNH and general description (may also be part of other ES measurements).

12. Questions that may be addressed by the data:

- Which SNH intercepts most soil (under similar upslope length and weather)? Compare soil capture at upslope to downslope locations in the SNH.
- How do the relative amounts captured compare to calculations with the RUSLE model? Requires RUSLE or BUFFERS modelling for which support will be provided by WU and GWCT.

3.4.2.4 Reference

Owens, P.N., Duzant, J.H., Deeks, L.K., Wood, G.A., Morgan, R.P.C., and Collins, A.J. (2007). Evaluation of contrasting buffer features within an agricultural landscape for reducing sediment and sediment-associated phosphorus delivery to surface waters. *Soil Use Manage.* 23(Suppl. 1), 165–175.

3.4.3 Landscape aesthetic

Beatrice Schüpbach

3.4.3.1 Aims and Needs

One of the examined 'other ecosystem services' is the effect of semi-natural habitats (SNH) on landscape aesthetics. The proposal aims at evaluating whether SNH are aesthetically preferred to crops.

Furthermore, the influence of the proportion of SNH in a landscape on the visual preference for the landscape should be evaluated. With pictures of SNH and crops in combination evaluated in a survey, data for the statistical model describing the services provided by SNH should be made available.

The main work will be done in one or two master thesis organized at ART. However, each partner will have to provide pictures of crops, SNH and the combination of crop and SNH at 4 different stages, as well as of typical landscapes depicting sites with crops without SNH and sites with crops and SNH. The timing for taking the photographs is synchronised with traits survey (T1, T2, T3 and T4).

For the final statistical model evaluating the services provided by SNH, a value for the aesthetic preference for the four stages should be provided. However, depending on the number of pictures and the survey method, it could be, that a mean value for each type of combination will be taken into account, not a value for each site.

3.4.3.2 Research Question, case studies and hypotheses

3.4.3.2.1 Research question

Which influence has the type of element, i.e. SNH, crop, or a combination of them, and its seasonal stage on the aesthetic preference of the pictures.

3.4.3.2.2 Case studies

In order to cover a broad range of crops but to avoid double investigations, we propose to investigate for each participating country one crop type, the selected SNH and the combination of them. Therefore, in the participating countries, the following crops should be photographed:

- Netherlands: Fruit trees
- France: Vineyards
- Italy: Olive groves
- Hungary: Sunflowers
- United Kingdom: Wheat
- Germany: Pumpkin
- Switzerland: Rape seed.

3.4.3.2.3 Hypotheses and statistical variables

The following hypotheses are based on photographs of elements and combination:

- 1) Hypothesis about single habitats:
 - a) Pictures of grassy SNH and crop habitats are differently rated regarding their aesthetic value.
 - b) Pictures of woody SNH and crop habitats are differently rated regarding their aesthetic value.
 - c) Pictures of woody SNH and grassy SNH are differently rated regarding their aesthetic value.
 - d) Pictures of flowering and not flowering habitats are differently rated regarding their aesthetic value.
- 2) Hypothesis about the combination of crop and SNH:
 - a) Pictures of a crop bordered by a grassy or a woody SNH or no SNH (i.e. another crop) are differently rated regarding their aesthetic value.
 - b) Pictures of flowering and not flowering habitats are differently rated regarding their aesthetic value.

3.4.3.3 Pictures

We propose to take photographs from the single focal crop field, the single SNH and the combination of crop and SNH of each of the 18 sites. Each photograph should be repeated at the four stages when the traits survey has to be done (T1, T2, T3 and T4). For sites with no adjacent SNH, the focal crop field should be depicted alone as well as combined with the adjacent crop. Take always the left crop field in view direction. It can also be high input grassland. In addition, 2-3 photographs of typical landscapes of

the three types (no SNH, SNH woody and SNH grassy) should be taken at T1 and T3. For the details, see section 4. For the definition of T1 – T4 see table 1 below.

Table 1: Dates for T1 – T4 for taking photographs for each country.

	T1	T2	T3	T4
Phenological zone	1. sampling Start vegetation period Sampling 2014	2. sampling	3. sampling	4. Sampling Six weeks before the end of the vegetation period (in brackets)
Italy, France	31.3.	12.5.	23.6.	23.9. (4.11.)
Hungary, France, Germany	10.4.	22.5.	3.7.	23.9. (4.11.)
Netherland, UK, Switzerland	15.4.	27.5.	8.7.	23.9. (4.11.)
Estonia	5.5.	9.6.	21.7.	18.9. (30.10.)

As these dates are adapted to the phenology of SNH, it can be that the focal crops are not yet or no more flowering at the defined date. However, landscape elements (including crops) are usually highest rated when they are flowering. Then, **we also have to provide pictures of the focal crop flowering** to complete the comparison. **Therefore, please take the same photographs (SNH, focal crop and combination) again at the next possible date before or after the date of table 1 with sunny weather when the focal crop is flowering.** Example for sunflower in Hungary: If the sunflower field is not yet flowering on July 3, please take the photographs at the next sunny day when the field is flowering. The same applies for all flowering crop fields. Nevertheless, if it is foreseeable, that on April 15 the fruit trees in the Netherlands will no more be flowering, please take the photograph before. For wheat please make sure, that the field once is yellow. The landscape photograph can be taken at the stage where the focal crop field is flowering (the wheat is yellow). **Please keep also in mind, that the traits survey can be done +/- 3 days around the dates provided in the table above.**

List of photographs needed

- Photographs of one focal crop field per country (see section “Case studies”), at the four stages → 4 photos per site, each site should be photographed.
- Photographs of the focal crop field in combination with an adjacent crop at the four stages → 4 photographs per site, each site should be photographed.
- Photographs of grassy SNH at the four stages → 4 photographs per site, each site should be photographed.
- Photographs of woody SNH at the four stages → 4 photographs per site, each site should be photographed.
- Photographs with woody SNH in combination with the focal crop field at the four stages → 4 photographs per site each site should be photographed.
- Photographs with grassy SNH in combination with the focal crop field at the four stages → 4 photographs per site, each site should be photographed.

- Photographs of 2-3 landscapes typical for the three types (no adjacent SNH, SNH woody and SNH grassy) taken at T1 and T3. Two photographs per site, 3 x 2-3 sites.

3.4.3.4 *Methods for taking photographs*

General advices:

- Photographs should be taken synchronised with the traits survey (T1, T2, T3 and T4. However, photographs should be taken always at sunny weather.
- Take the photographs always at the same time in the day, preferably around noon (short shadows, good light). Avoid pictures against the sun (a reason to take the photograph a bit earlier or later in the day).
- Avoid power lines, buildings or roads on the photograph; at least in the foreground or power lines in front of the sky
- Landscape photographs should have a neutral background. No power lines nor dominant buildings.
- Field allocation parallel to a slope is favourable. Also a slight upward slope in the longer axis of the field.
- Be aware, that you can take the photographs from either side of a field.
- Please use always the same camera. The camera should provide a 600 dpi resolution. Mobile phones are not adapted to such pictures.

Rules for photographs of a single elements and the combination of crop and SNH.

All photographs are taken in a distance of 10 – 30 m from the element or the combination of elements that should be depicted (see figure 1). The view direction should make an angle of about 10 – 30° from the base line of the fields. The reason is, that a hedgerow can't be photographed from a point directly in front of it. The distance and the angle must be adapted to the height of the hedgerows but should be constant within one country. The distance and the angle should be optimized so as the element(s) fill the whole photograph as much as possible (see figure 2).

For element photographs a focal length of about 50 mm should be used. The element should fill the whole photograph. See figure 1 and 2 below.

For the combination of a focal crop field and SNH the same point should be used to take the photograph however, a slightly different angle and a focal length of about 35 to 40 mm should be used. The two elements should fill the whole photograph (see figure 1 and 2), and nevertheless both elements should be visible. Take for all combinations the same focal length.

For the combination of a focal crop field with another crop field, the adjacent crop field to the left in view direction should be depicted (see figure 2). This field can also be a high input grassland.

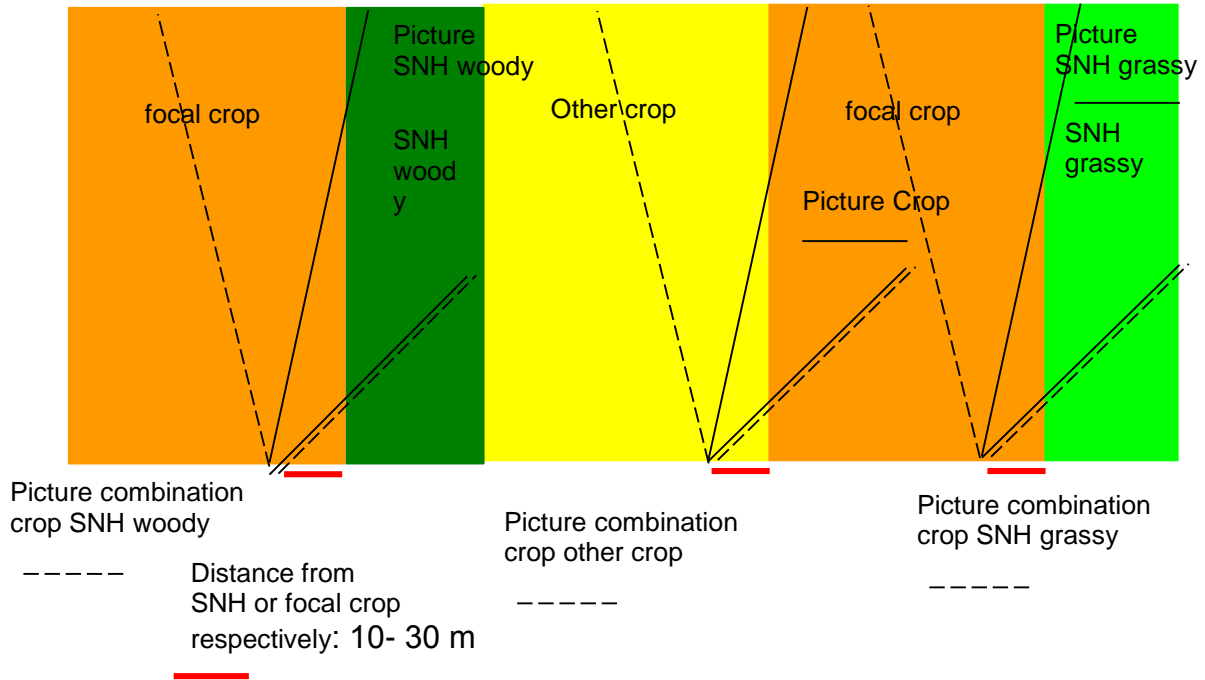

Figure 1: How to take a photograph for the 'single element' and the combination.

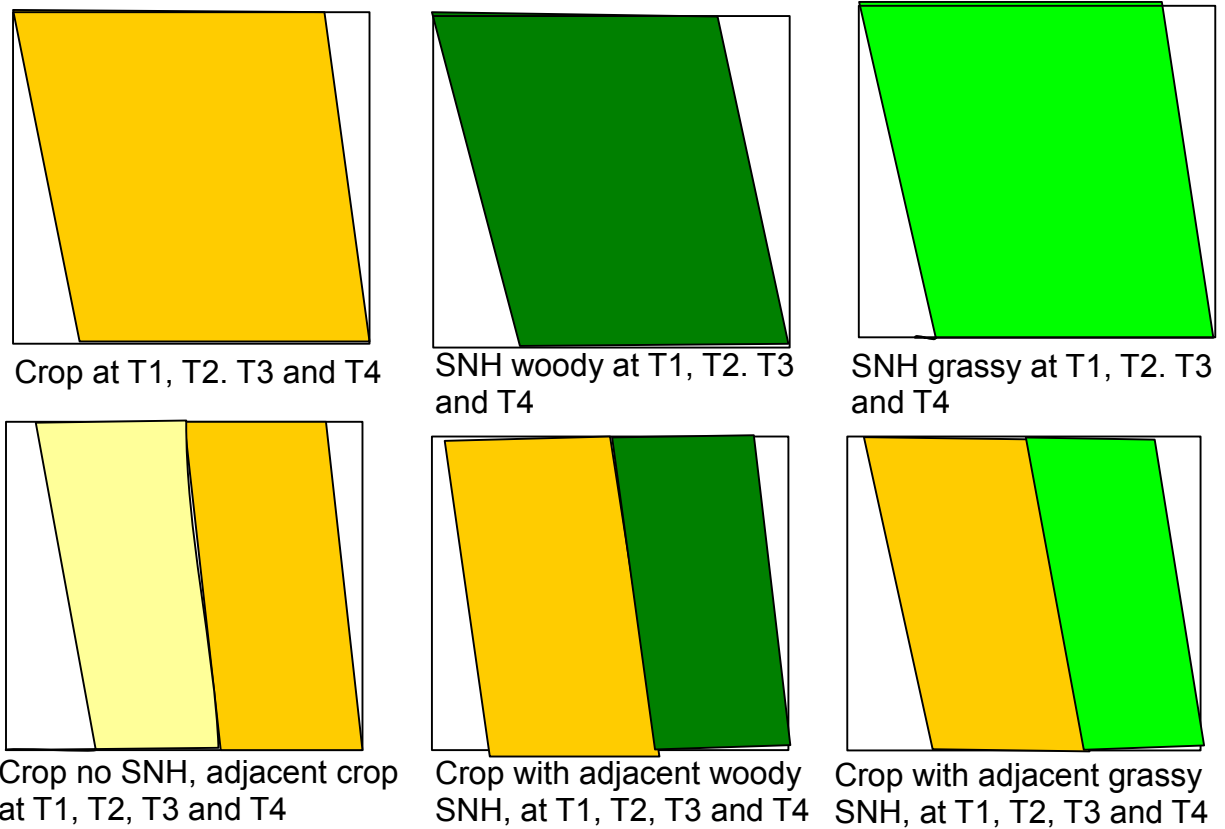

Figure 2: Prototype for all pictures depicting elements or combination of elements. Each element or combination is photographed at four stages (T1, T2, T3 and T4).

In the following good and bad examples of photographs with landscape elements (single crop or SNH) are shown.



- ✓ Nothing but crop and SNH
- ✓ Only the sky in the background

Figure 3: good example for the combination focal crop field – SNH woody. The picture was taken about 30 m from the hedgerow with an angle of about 30° from the field base line. The crop in the foreground would be the focal crop field.



- ✓ Good distance, good scale, neutral background.
- ✗ Forest and hedgerow at the edge of the picture. May be no more a problem when the crop grows. Sky too pale.



- ✗ Too close
- ✗ Building and forest in the background; background distracts from the crop.



- ✓ Good distance, good scale, neutral background.
- ✗ Bad quality of the element in the foreground. Crop field at the edge of the picture. Sky too pale



- ✗ Too close
- ✗ Bad contrast between wild flower strip and forest.

Figure 4: good examples (left) and bad examples (right) for a photograph of a single element.

Photographs of the landscapes

The landscape photographs should be taken at T1 and T3 of the traits survey. They should depict a typical landscape for the three situations of no adjacent SNH, SNH grassy or SNH woody adjacent. Therefore for each type 2-3 suitable sites should be photographed. Suitable means that the picture is identified as a landscape picture but the singular elements are clearly visible. Particularly the SNH elements. The pictures should be characterized by a diverse foreground but should not have a dominant background. The pictures will be included in the survey. Either as illustration or as choice element. One idea is to use photo editing during the master thesis in order to manipulate the proportion of SNH. See also section 5. Examples of pictures see below.



✓ More or less diverse foreground.

✗ Too much background, too much diversity in the background



✗ Foreground too much homogeneous

✗ Settlement area and hills in the background



✓ Good foreground and almost no background.

✗ The trees should not be cut

Figure 5: good examples (left) and bad examples (right) for a photograph a 'typical' landscape. People doing their field work of course should not be on the photograph.

Please send the first photographs as soon as they are taken to Beatrice Schüpbach, Agroscope, ISS (beatrice.schuepbach@agroscope.admin.ch). When doing so, please zip the whole folder of your country (see figure 6 and 7) before sending. Probably this will not work as the file is too big. In this case send a simple e-mail and you will get an invitation to use the ftp-server of the Swiss Confederation.

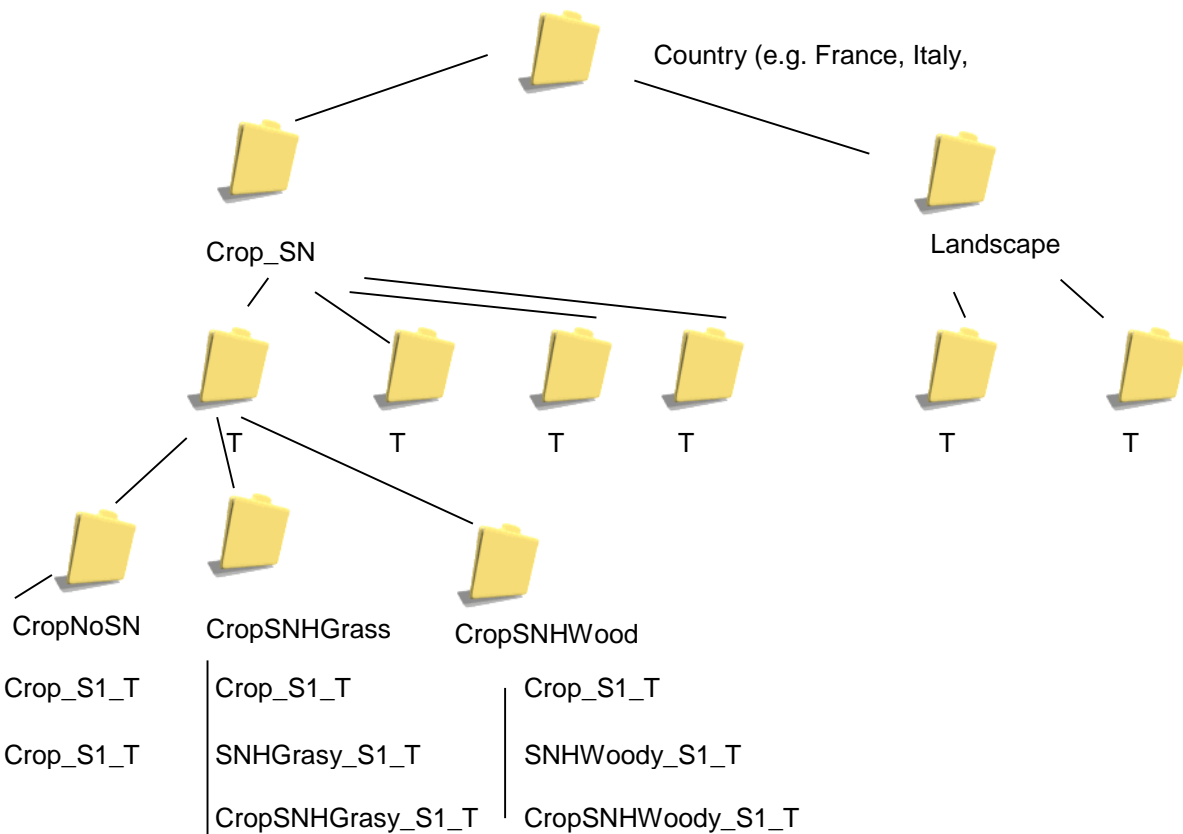

Figure 6: folder structure for pictures of single elements and crop – SNH combinations.

The folder structure separates pictures of crops, SNH and its combination from landscape pictures. On the next level the time of taking the picture (T1 – T4) is separated. Thereafter the three types of situation are separated: the focal crop field with no adjacent SNH, the focal crop field with SNH grassy and SNH woody respectively. In this folder finally are the pictures. Please use the names as in figure 6 and 7. For ‘crop’ please use the name of the crop. For a picture of site 1 of a combination of a vineyard with a grassy SNH at T1 the name would be: VineyardSHNGrassy_S1_T1. Please rename your pictures following this nomenclature. For the landscapes the same rules are applicable. Only the landscape pictures have an ‘L’ at the beginning of the name. Furthermore, pictures are taken only at T1 and T3 and only form 3 typical sites. For the details see figure 7.

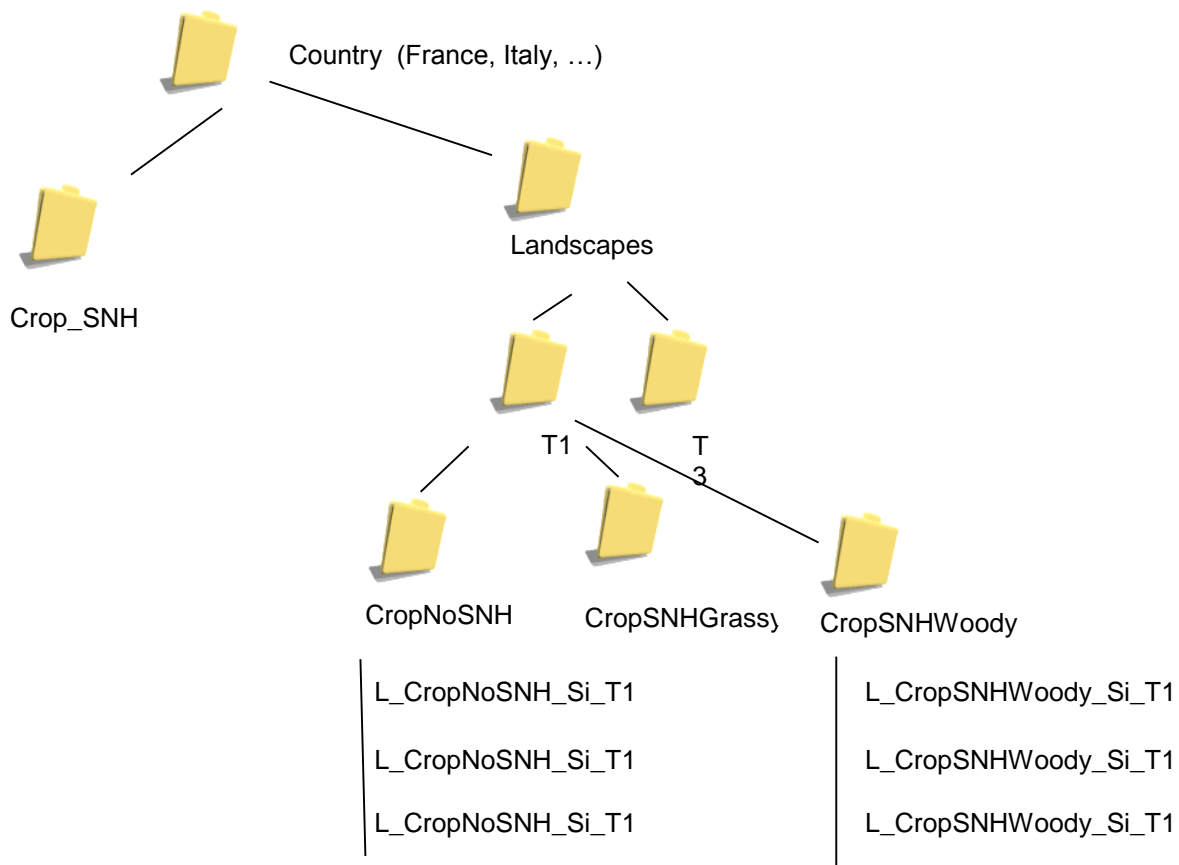

Figure 7: folder structure for pictures of landscapes in the different types (crop no SNH, crop with woody SNH and crop with grassy SNH). Si means the number of the respective site. The landscapes of three typical sites should be depicted.

3.4.3.5 Photo survey and Master Thesis

The evaluation of the pictures should be done with a discrete choice model as it forces the participants to decide for one option and avoids an accumulation of valuations around the mean value of the scale. As this proceeding is complex and needs photo edition we propose to develop this survey and its analysis by a master student supervised at ART. A close collaboration will be required with SOLAGRO for the preparation of the survey. Each case study will need then to establish a list of organizations, institutions, people to which the survey will be addressed.

3.4.4 Disservices

By *Camilla Moonen*

3.4.4.1 Aim

The aim is to quantify the type and amount of disservices for agriculture originating from 1) the presence of SNH adjacent to the cropped fields and 2) the amount and type of SNH that dominates the landscape sector. The main disservices connected to SNH as mentioned by farmers are:

- Only for annual crops: Crop seed or seedling predation by birds just after sowing or transplanting
- Yield predation by birds and wild life at harvest time
- Weeds invading the cropped field
- Pest species invading the cropped field
- Yield reduction in the crop margin due to shading comparing border effects from all 18 FF (and thus their 3 SNH margin types: 6 woody, 6 herbaceous and 6 without).

3.4.4.2 Hypotheses

Disservice	Crop type	Adjacent SNH	% land use cover in landscape sector
Crop seed/seedling predation	Annual crops	H1: the closer the FF is to a woody SNH, the higher seed predation.	H2: the more villages and abandoned sheds (pigeons) and woodland (wild pigeons, crows), the higher seed predation.
Yield predation	Annual grain crops Fruit trees	H1: fields adjacent to a big woody SNH have higher yield loss due to wild life attack than field without such elements	H2: FF in landscape sectors with high percentage of woody areal SNH have higher yield loss due to wildlife.
Weed invasions	All crops	H1: Weed invasions in the FF will be higher adjacent to herbaceous SNH than next to woody elements because woody vegetation is less adapted habitat for species of disturbed habitats. H2: the effect will be limited to the outer 10-15 m of the field.	H3: The SNH habitat composition and crop typology of the landscape sector affect the dominant traits (CRS-classification; Ellenberg values, growth-form) of the weed communities in the FF since these habitat are the source from which potential weeds invade the FF.
Pest invasions	All crops	Hypothesis depends on specific potential pest. To be defined by CS partner that wants to test this.	Hypothesis depends on specific potential pest. To be defined by CS partner that wants to test this.
Shading	Herbaceous crops	H1: yield is lower in outer m of cropped field regardless of SNH type H2: yield reduction in outer 10-15 m of field higher next to woody elements than next to	Not relevant at landscape scale

		herbaceous elements.	
--	--	----------------------	--

3.4.4.3 Protocol

All 5 possible disservices are optional for all CS partners.

CS	Crop seed predation	Yield predation	Weed invasions	Pest invasions	Shading
GWCT- cereals				X	
GWCT-OSR					
UKL-pumpkin					
SZIE-sunflower					
SZIE-cereals					
DLO-pear	Nr				
EULS-OSR				Pan traps for Meligethes, Ceutorhynchus	
France-vine	Nr				
IT-olive	Nr	Yes, olive fly invasion level	nr	To be confirmed: olive fly from abandoned olive groves	No
IT-sunflower	X	X	X	nr	no
ART-OSR		X if relevant	X	X Meligethes	

nr = not relevant

1. Crop seed or seedling predation

Time requirement: depends how often you planned to go to the field and how close in contact you are with farmers. However, most information can be recovered through observation in the field once you are there and farmer interviews or a simple phone call: 2 days?

Measures	How	Where
Response variable		
a. Surface (ha) attacked	1) Observation in the field after crop emergence. Sketch of field and surface attacked to be transferred to GIS to calculate surface 2) Ask farmer for surface lost or resown	FF unit
b. Percentage of cropped area attacked by wildlife	Calculation: surface attacked/surface FF*100%	FF unit
c. Nb of seeds or plants lost	Calculation: seed or plant density * surface attacked	FF unit
Explanatory variable		
a. % woody areal in	From GIS map	Landscape sector

landscape sector		
b. % habitation in landscape sector	From GIS map	Landscape sector
c. Type of adjacent SNH	Field observation/GIS map	FF unit
Additional information		
1) Sowing density	Ask farmer	FF unit
2) Desired plant density	Ask farmer	FF unit
3) Seed loss in other fields with same crop in the landscape sector	Ask farmer to indicate on the map	Landscape sector
4) Seed loss in other fields in other areas	Ask farmer to indicate on the map	Regional level
5) Predators	Ask farmer	FF unit

2. Yield predation

Time requirement: Probably you need to go to the field at harvest-time anyway, so making an estimate of attacked surface should be easy. Other information retrieved by making a phone call and inserting data in GIS map to calculate surface. 1 day?

Measures	How	Where
Response variable		
a. Surface (ha) attacked by wild life or pest insects or diseases	1) Observation in the field just before crop harvest. Sketch of field and surface attacked to be transferred to GIS to calculate surface 2) Ask farmer for surface lost	FF unit
b. Percentage of cropped area attacked by wildlife	Calculation: surface attacked/surface FF*100%	FF unit
c. Estimate % Yield loss	Ask farmer after harvest; if known for the part of the field that was not attacked, otherwise mean of all his fields with specific crop: then calculation: (yield in t/ha * surface attacked)/(production per ha (t/ha)* total field surface)*100%	FF unit or crop totals at farm level
d. Measured % yield loss (precise but time consuming)	Determine difference in yield between an area protected from bird/wild life attack and attacked part.	Need experimental part in the field where yield will be protected and measure yield difference in lab by measuring weight of yield o fixed surface.
Explanatory variable		
a. % woody areal in landscape sector	From GIS map	Landscape sector

b. Type of adjacent SNH	Field observation/GIS map	FF unit
Additional information		
1) Yield loss in other fields with same crop in the landscape sector	Ask farmer to indicate on the map	Landscape sector
2) Yield loss in other fields in other areas	Ask farmer to indicate on the map and quantify for each field	Regional level
3) Predators	Ask farmer	FF unit

3. Weed Invasions

Time requirement: 4 h for 1 field → 9 days for field work. Data input and analysis: 2 weeks.

Measures	How	Where
Response variable		
Weed cover and density by species	Count of all individuals in 1x1 m quadrats, identify at species level and estimate also % cover per species. Timing: after main weed control intervention and when most relevant for the crop. Sunflower: 2 to 3 weeks after post-emergence treatment in order to catch species that will mature in the crop and set seed.	Transects in FF from main SNH Follow transects from general protocol but measure at 1, 2, 10, 15, 25, 50 and 75 m. More measures necessary near field margin because weed gradient is concentrated in first 10-15 m and QuESSA protocol distance would cover that in enough detail. However, if your distances are not the indicated ones but the adapted ones, use those in order to combine with other measurements and flower abundance data.
Cover and density by traits	Connect species list to plant traits database	At data analysis
Explanatory variable		
Distance for adjacent SNH	Known	FF unit
Type of SNH adjacent	Known	FF unit
Land use and SNH typology in landscape sector at different distances from FF	From GIS mapping	Landscape sector
Additional information		
SNH management	From interviews to be held in winter 2014 and 2015	FF unit
Crop management	From interviews to be held in winter 2014 and 2015	FF unit
Weed traits database	To be created in WP2	Project level

4. Pest Invasions

Time requirement: Pest and measurement methods dependent but likely similar to weed invasion
 measurement: 1 months

Measures	How	Where
Response variable		
Pest dependent	Pest dependent	Pest dependent
Cereal aphids in wheat (UK)	Tiller counts x 25	At each point along transect for sentinel systems
Meligethes (ART)	As in OSR specific protocol	See OSR protocol
Explanatory variable		
Distance for adjacent SNH	Known	FF unit
Type of SNH adjacent	Known	FF unit
Land use and SNH typology in landscape sector at different distances from FF	From GIS mapping	Landscape sector
Additional information		
SNH management	From interviews to be held in winter 2014 and 2015	FF unit
Crop management	From interviews to be held in winter 2014 and 2015	FF unit

5. Crop shading

Time requirement: if you were in the field anyway before harvest, little more time lost but 1 week to sort, treat, dry and weight samples.

Measures	How	Where
Response variable		
Crop yield	Collect production in a relevant surface for the specific crop, measure fresh weight, oven-dry at 60°C and give dry weight.	At 1, 2, 5, 10, 15, 25, 25, 75 m in the two transects from general protocol
Crop quality	Based on crop, crop quality measures can be taken <ul style="list-style-type: none"> • Sunflower: oil content and composition 	
Explanatory variable		
Distance for adjacent SNH	Known	FF unit
Type of SNH adjacent	Known	FF unit
Additional information		
Crop management	From interviews to be held in winter 2014 and 2015	FF unit