

Contents lists available at [ScienceDirect](https://www.sciencedirect.com)

Analytica Chimica Acta

journal homepage: www.elsevier.com/locate/aca

Vacuum in-tube extraction (V-ITEX): A tutorial review of theoretical principles, operational parameters, and applications

Lucie K. Tintrop^{a,*}, Simon Wacker^a, Florian Kopiec^b, Stefan Cretnik^c, Pascal Fuchsmann^a

^a Agroscope, Schwarzenburgstrasse 161, Bern, 3003, Switzerland

^b Gerstel, GmbH & Co. KG, Eberhart-Gerstel-Platz 1, Mülheim an der Ruhr, 45473, Germany

^c CTC Analytics AG, Industriestrasse 20, Zwingen, 4222, Switzerland

HIGHLIGHTS

- Vacuum during headspace extraction increases sensitivity and volatility and enhances sorption.
- Vacuum in-tube extraction (V-ITEX) shows broad applicability across food, biological, biotechnological and microbial samples.
- V-ITEX is the first fully automated vacuum-assisted microextraction technique.

GRAPHICAL ABSTRACT

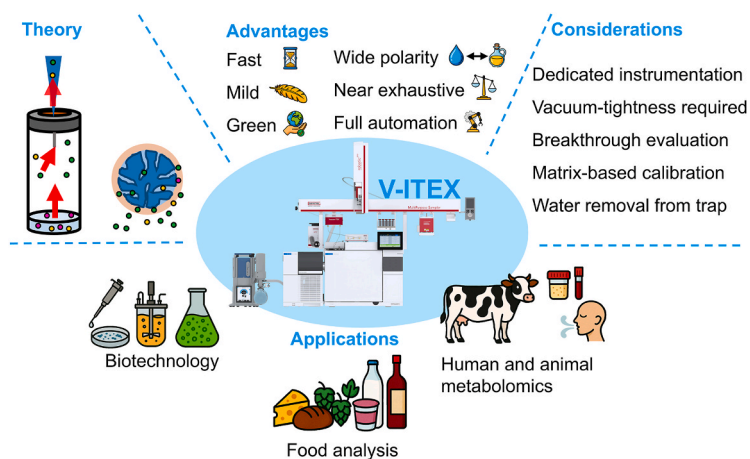

ARTICLE INFO

Keywords:

Microextraction
Sample preparation
Vacuum in-tube extraction
Dynamic headspace extraction
Volatile organic compounds
Semi-volatile organic compounds
Gas chromatography mass spectrometry

ABSTRACT

Headspace-based microextraction techniques, such as solid-phase microextraction (SPME) and in-tube extraction (ITEX) are commonly used as pre-concentration steps prior to gas chromatography mass spectrometry (GC-MS) for the analysis of volatile organic compounds. However, these techniques often face limitations when dealing with semi-volatile organic compounds, polar analytes, or complex matrices. Recently, the application of vacuum has emerged as an additional operational parameter capable of overcoming these constraints by enhancing mass transfer while utilizing mild extraction conditions. Vacuum in-tube extraction (V-ITEX), introduced in 2019, combines controlled reduced pressure, dynamic headspace extraction, and sorbent trapping. This tutorial review summarizes the fundamental principles of V-ITEX, explains the underlying theoretical principles, outlines key operational parameters and evaluates performance characteristics and limitations. Representative applications,

This article is part of a special issue entitled: ExTech 2025 published in *Analytica Chimica Acta*.

* Corresponding author.

E-mail addresses: lucie.tintrop@agroscope.admin.ch (L.K. Tintrop), simon.wacker@agroscope.admin.ch (S. Wacker), florian_kopiec@gerstel.de (F. Kopiec), SCretnik@ctc.ch (S. Cretnik), pascal.fuchsmann@agroscope.admin.ch (P. Fuchsmann).

<https://doi.org/10.1016/j.aca.2026.345539>

Received 4 February 2026; Received in revised form 8 April 2026; Accepted 14 April 2026

Available online 21 April 2026

0003-2670/© 2026 The Authors. Published by Elsevier B.V. This is an open access article under the CC BY license (<http://creativecommons.org/licenses/by/4.0/>).

such as food characterization and metabolomics in human and animal studies are presented. Practical troubleshooting strategies and best-practice recommendations are provided to support implementation of V-ITEX in analytical workflows. Overall, the review highlights the potential of V-ITEX as an alternative approach for headspace extraction, while emphasizing critical parameters that must be controlled for robust analytical performance.

1. Introduction

1.1. Microextraction and headspace sampling

Microextraction techniques have become a cornerstone of modern analytical chemistry by enabling the isolation and enrichment of volatile organic compounds (VOCs) and semi-volatile organic compounds (SVOCs). Since Arthur and Pawliszyn's pioneering work on solid-phase microextraction (SPME) in 1990 [1], numerous sorptive and solvent-based approaches have been developed, including in-tube extraction (ITEX) [2], liquid-phase microextraction (LPME) [3], and thin-film microextraction (TFME) [4]. These techniques operate in either direct immersion (DI) mode, in which the extraction phase is directly exposed to the sample matrix, or headspace (HS) mode, in which analytes partition into the gas phase prior to extraction [5]. The process of HS extraction, applied as sample preparation tool for gas chromatography mass spectrometry (GC-MS), has been demonstrated to be an effective method of reducing matrix interferences as it keeps non-volatile constituents to the sample phase. The HS sampling can be performed under either static or dynamic conditions. In static HS, an equilibrium HS aliquot is sampled after incubation. In dynamic HS, a continuous gas flow or several cycles transport the analytes from the sample to a sorbent [5]. Static HS techniques offer operational simplicity; however, they are frequently limited in terms of sensitivity for SVOCs. Dynamic methods generally yield higher recoveries due to continuous analyte transfer and subsequent re-equilibration but they are more operationally challenging and time-consuming. To overcome these limitations, vacuum has been introduced as an additional operational parameter for HS microextractions.

1.2. Conventional in-tube extraction (ITEX)

ITEX was first described in 2008 by Jochmann et al. [2] and is an automated dynamic HS microextraction technique that integrates sorptive enrichment directly into an autosampler-based workflow prior to GC-MS analysis. Since then it has been used for VOC analysis in several different applications such as plants [6], berries [7], air [8], alcoholic beverages [9,10], and honey [11]. In addition, publications on different topics have been published such as optimization strategies [12], and application to aqueous samples [13]. The method was introduced as an alternative to static HS extraction and solid-phase microextraction (SPME) for VOC analysis. In contrast to static microextraction techniques such as SPME, ITEX operates as a dynamic extraction system in which HS gas is actively transported through a sorbent trap. The core principle of ITEX relies on repeated aspiration and dispensing cycles of HS gas through the trap integrated into a gas-tight syringe assembly. During extraction, the autosampler draws defined volumes of HS gas from the vial and passes them through the sorbent. Target analytes are retained by the sorbent. The gas phase, largely depleted of analytes, is then expelled back into the vial. This aspiration-dispensing cycle is repeated multiple times, progressively increasing the amount of analyte accumulated on the sorbent. Operationally, the ITEX workflow is fully integrated into automated autosampler systems and typically consists of several sequential steps.

First, the sample vial is incubated at a defined temperature to establish HS equilibrium between the sample phase and the gas phase. During this incubation step, agitation may be applied to accelerate mass transfer. After equilibration, the autosampler needle containing the

ITEX trap is inserted through the septum into the vial HS. The extraction process is then initiated by performing a defined number of extraction cycles. Key parameters governing extraction efficiency include the number of extraction cycles, the aspirated HS volume per cycle, extraction temperature, and the properties of the sorbent material. After completion of the extraction cycles, the trap containing the enriched analytes is transferred to the GC injector. Thermal desorption is performed directly in the inlet liner under a carrier gas flow, releasing the trapped compounds onto the GC column for GC-MS analysis. Following desorption, the trap is conditioned at elevated temperature under inert gas flow to remove residual analytes and prepare the system for the next extraction cycle.

ITEX offers several advantages in routine analytical workflows. Because fresh HS gas is continuously passed through the trap, ITEX achieves higher sensitivity compared with static HS techniques that rely solely on equilibrium partitioning. The technique benefits from the relatively large sorbent capacity compared with fiber-based microextraction techniques, which reduces the risk of saturation and improves robustness for samples containing higher analyte concentrations. The technique is fully automated and integrated into autosampler platforms, enabling high sample throughput. Compared with solvent-based extraction methods, ITEX requires minimal sample preparation and avoids the use of organic solvents.

Despite these advantages, conventional ITEX also exhibits certain limitations. Because extraction relies on repeated aspiration of HS gas rather than continuous gas flow, the enrichment efficiency can be limited for analytes with slow mass transfer from the sample phase. This can result in incomplete analyte transfer for compounds with low volatility or strong matrix interactions requiring elevated temperatures or extended extraction cycles to achieve sufficient sensitivity. These limitations have motivated the exploration of modified extraction conditions that enhance mass transfer and analyte transport toward the sorbent phase. One such modification is the application of reduced pressure during extraction [2,12,13].

1.3. Vacuum-assisted headspace microextraction techniques

Applying a vacuum during HS extraction reduces total system pressure. This creates advantageous physicochemical effects that enhance extraction performance. SPME was the first microextraction technique tested under vacuum conditions, as reported by Brunton et al., in 2001 [14]. Since then, vacuum-assisted HS-SPME (Vac-HS-SPME) has been used for the extraction of compounds from several matrices including grapes [15], source rocks [16], soil [17], hemp [18], olive oil [19], fish [20] and tomatoes [21]. However, since SPME is usually fully automated, vacuuming the sample container is an additional manual step [22]. Several review articles on Vac-HS-SPME have been published since that time, addressing a general tutorial [22], applications in environmental analysis [23,24], the influence of Henry's law constant [25], and additional topics which are summarized in Table 1.

Recently, vacuum-assisted microextraction has been extended to techniques with high-capacity sorption phases. These include vacuum-assisted sorbent extraction (VASE) in 2018 [27], dynamic HS vacuum transfer in-trap extraction (also known as vacuum in-tube extraction, V-ITEX) in 2019 [28], vacuum-assisted HS sorptive extraction (also known as HS stir-bar sorptive extraction, Vac-HS-SBSE) in 2020 [29], vacuum-assisted thin-film microextraction (Vac-HS-TFME) in 2022 [30] and vacuum-assisted SPME arrow in 2023 [31].

Table 1

Collection of research articles and review articles on vacuum-assisted microextraction techniques in chronological order. SPME: solid-phase microextraction.

	Topic	First author, Year	Ref.
Research articles	First article to vacuum-assisted SPME <i>The effects of temperature and pressure on the performance of Carboxen/PDMS fibres during solid phase microextraction (SPME) of headspace volatiles from cooked and raw turkey breast</i>	Brunton, 2001	[14]
	Vacuum-assisted SPME for soil samples <i>Simple, Low-Cost and Reliable Device for Vacuum-Assisted Headspace Solid-Phase Microextraction of Volatile and Semivolatile Compounds from Complex Solid Samples</i>	Beiranvand, 2017	[17]
	Magnetic ionic liquids in vacuum headspace single-drop microextraction <i>Magnetic ionic liquids as extraction solvents in vacuum headspace single-drop microextraction</i>	Trujillo-Rodríguez, 2017	[26]
	Vacuum-assisted sorbent extraction (VASE) for phenols in beer <i>Use of Sorbent-Based Vacuum Extraction for Determination of Volatile Phenols in Beer</i>	Jeleń, 2018	[27]
	Vacuum-assisted in-tube extraction performance evaluation <i>Development and performance evaluation of a novel dynamic headspace vacuum transfer "In Trap" extraction method for volatile compounds and comparison with headspace solid-phase microextraction and headspace in-tube extraction</i>	Fuchsmann, 2019	[28]
	Vacuum-assisted headspace sorptive extraction (stir-bar sorptive extraction) proof of concept applied to water samples <i>Vacuum-assisted headspace sorptive extraction: Theoretical considerations and proof-of-concept extraction of polycyclic aromatic hydrocarbons from water samples</i>	Solomou, 2020	[29]
	Vacuum-assisted SPME for environmental pollutants <i>Heating-, Cooling- and Vacuum-Assisted Solid-Phase Microextraction (HCV-SPME) for Efficient Sampling of Environmental Pollutants in Complex Matrices</i>	Ghiasvand, 2020	[24]
	Vacuum-assisted SPME for source rock analysis <i>Vacuum-assisted headspace solid-phase microextraction and gas chromatography coupled to mass spectrometry applied to source rock analysis</i>	Pollo, 2022	[16]
	Vacuum-assisted TFME for water samples <i>Vacuum-assisted headspace thin-film microextraction: Theoretical formulation and method optimization for the extraction of polycyclic aromatic hydrocarbons from water samples</i>	Yiantzi, 2022	[30]
	Vacuum-assisted SPME for hemp terpenoids and cannabinoids <i>A sustainable approach for the reliable and simultaneous determination of terpenoids and cannabinoids in hemp inflorescences by vacuum assisted headspace solid-phase microextraction</i>	Capetti, 2022	[18]

Table 1 (continued)

	Topic	First author, Year	Ref.
Review articles	Vacuum-assisted high capacity SPME (SPME arrow) for mushroom samples <i>Comparison of fragrance and flavor components in non-psilocybin and psilocybin mushrooms using vacuum-assisted headspace high-capacity solid-phase microextraction and gas chromatography-mass spectrometry</i>	Thomas, 2023	[31]
	Vacuum-assisted and multi-cumulative trapping in headspace SPME for virgin olive oil aroma <i>Vacuum-assisted and multi-cumulative trapping in headspace solid-phase microextraction combined with comprehensive multidimensional chromatography-mass spectrometry for profiling virgin olive oil aroma</i>	Mascrez, 2024	[19]
	Review on effect on Henry's law constant in vacuum-assisted headspace SPME <i>Effect of Henry's law constant and operating parameters on vacuum-assisted headspace solid phase microextraction</i>	Psillakis, 2012	[25]
	Review on vacuum-assisted headspace SPME extraction of semi-volatiles <i>Vacuum-assisted headspace solid phase microextraction: Improved extraction of semivolatiles by non-equilibrium headspace sampling under reduced pressure conditions</i>	Psillakis, 2012	[32]
	Tutorial review on vacuum-assisted headspace SPME <i>Vacuum-assisted headspace solid-phase microextraction: A tutorial review</i>	Psillakis, 2017	[22]
	Review on vacuum-assisted headspace SPME for environmental sampling of water and soil <i>A critical review of vacuum-assisted headspace solid-phase microextraction for environmental analysis</i>	Zhakupbekova, 2019	[23]
	Review on vacuum-assisted headspace single-drop microextraction and elimination of interfacial gas-phase limitations <i>Vacuum-assisted headspace single-drop microextraction: Eliminating interfacial gas-phase limitations</i>	Psillakis, 2019	[33]
	Review on vacuum as a parameter during headspace sampling <i>The effect of vacuum: an emerging experimental parameter to consider during headspace microextraction sampling</i>	Psillakis, 2020	[34]
	Review on vacuum-assisted headspace thin-film microextraction <i>Vacuum-assisted headspace thin-film microextraction: Theoretical formulation and method optimization for the extraction of polycyclic aromatic hydrocarbons from water samples</i>	Yiantzi, 2022	[30]

While several reviews and tutorial articles have addressed vacuum-assisted microextraction, they have primarily focused on equilibrium-based approaches such as Vac-HS-SPME. In contrast, the present tutorial provides the first dedicated and comprehensive overview of V-ITEX, a dynamic vacuum-assisted HS microextraction technique based on continuous gas-phase renewal and high-capacity sorbent trapping. By systematically linking theoretical principles with hardware design, operational parameters, automation, and application examples, this work extends existing literature and aims to serve as a practical

reference for implementing V-ITEX in analytical workflows.

2. Theory of vacuum-assisted headspace extraction

Applying a vacuum during microextraction changes the system conditions. The most influential effects are discussed in the following sections and are visualized in Fig. 1.

2.1. Thermodynamic aspects of phase partitioning

The distribution of a compound i between a liquid phase and its gas phase (here HS) is commonly described by Henry's law constant H_i^v , which relates the equilibrium partial pressure P_i of the compound to its mole fraction x_i in the liquid phase [5,35]:

$$H_i^v = \frac{P_i}{x_i}$$

here, the pressure-based definition is used, where a larger H_i^v corresponds to lower solubility of the analyte in the liquid phase. H_i^v is temperature-dependent and typically follows a van't Hoff relationship [36]:

$$\ln H_i^v = -\frac{\Delta H_{sol}}{R} \frac{1}{T} + C$$

where ΔH_{sol} is the enthalpy of dissolution, R is the universal gas constant ($8.314 \text{ J K}^{-1} \text{ mol}^{-1}$), T is the temperature and C is the integration constant.

2.1.1. Pressure effects and non-ideal behavior

In its classical form Henry's law assumes ideal gas behavior, which strictly applies only near ambient pressure. Under reduced pressure, non-ideality must be considered by replacing partial pressure with fugacity f_i [36,37]:

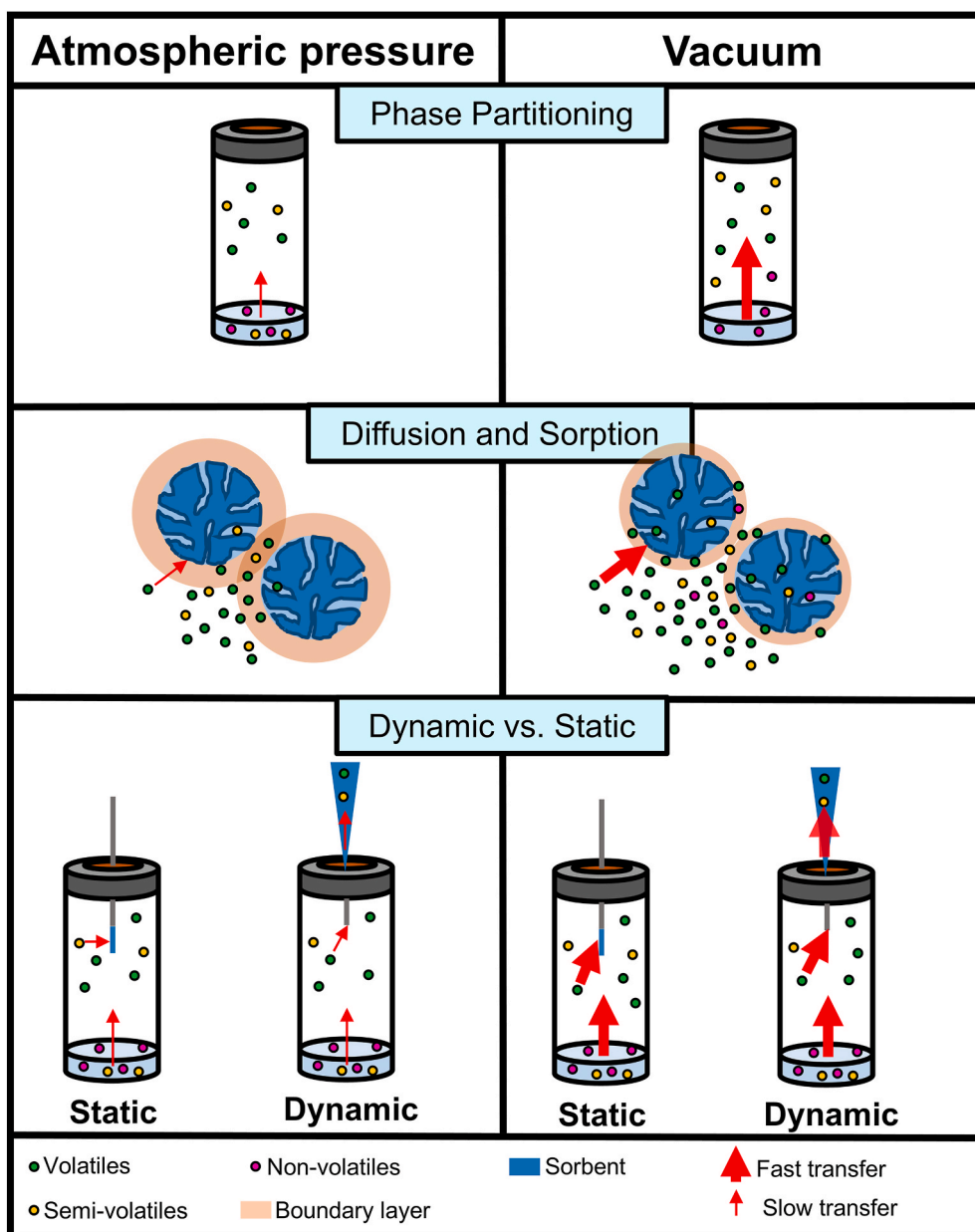

Fig. 1. Comparison of phase partitioning, diffusion, sorption and extraction modes under atmospheric pressure versus vacuum and static versus dynamic headspace extraction.

$$H_i^v = \frac{f_i}{x_i}, f_i = \phi_i y_i P$$

where P is the total pressure, y_i is the gas-phase mole fraction, and ϕ_i is the fugacity coefficient that accounts for non-ideal gas behavior. Under near-vacuum conditions, $\phi_i \rightarrow 1$, while the total pressure $P \rightarrow 0$ [37].

The pressure dependence of Henry's law constants can be described more rigorously by the Krichevsky-Kasarnovsky equation, which incorporates the dependence of Gibbs free energy on pressure [38]. This relationship accounts for changes in the apparent solubility of a gas with pressure and is expressed as [37,38]:

$$\ln \frac{f_i}{x_i} = \ln H_i^v + \frac{V_i^\infty}{RT} (P - P_j^{\text{sat}})$$

where V_i^∞ is a hypothetical partial molar volume of the solute i at infinite dilution, and P_j^{sat} is the saturation pressure of the pure solvent.

2.1.2. Implications for vacuum-assisted extraction

Theoretical considerations show that when total pressure decreases:

- the apparent Henry's constant decreases,
- analyte solubility in the sample phase declines,
- the equilibrium shifts toward the gas phase.

Thus, vacuum increases analyte availability in the HS, particularly for SVOCs and polar compounds that are otherwise poorly transferred under classical HS conditions.

2.2. Theoretical aspects of sorption processes

In HS microextraction, sorption processes control the uptake of gaseous analytes by the extraction phase. Understanding adsorption- and absorption-based mechanisms is essential for interpreting analyte extraction behavior and for predicting vacuum influence on analyte enrichment. Table 2 provides an overview of commercially available ITEX trap materials, categorized by their dominant sorption mechanism (adsorption, absorption, or dual-mode), which is critical for selecting appropriate sorbents based on analyte properties and extraction conditions. Sorbents such as Tenax TA and Tenax GR rely primarily on bulk absorption or dual-mode sorption, while materials such as Carbosieve SIII, Carboxen 1000, and Carpack C facilitate physisorption via surface adsorption. In mixed sorbent traps, polymeric and/or carbon-based materials are combined to extend the effective volatility range, with the defined sorbent layering promoting a mild volatility-dependent fractionation along the trap. π - π interactions and van der Waals forces are particularly relevant for aromatic and polar compounds, and the sorbent-specific properties (e.g., polarity, porosity, surface area) directly shape the extraction profile (see Table 2).

2.2.1. Adsorption

In adsorption, analyte molecules attach to the surface of the sorbent through physical or chemical interactions. This process is restricted to the external or internal surface area of the material and is therefore surface-limited. This is described by the Langmuir adsorption isotherm [41]:

$$q_i = \frac{q_{\text{max}} K_i P_i}{1 + K_i P_i}$$

where q_i is the absorbed amount of analyte adsorbed per unit mass of sorbent, q_{max} is maximum monolayer capacity, K_i is the equilibrium adsorption constant; and P_i is the analyte partial pressure.

2.2.2. Absorption

For porous materials, such as polymeric sorbents, compound sorption includes both surface adsorption and bulk absorption (also called

Table 2

Overview of the most common commercially available V-ITEX sorbent materials, including sorption type, material classification, physicochemical characteristics, and typical application ranges. Overall dual mode refers to the whole sorbent mixture.

Trap filling/ Sorbent name	Sorption type	Material type	Application information
Tenax TA	Absorption	Porous polymer (poly(2,6-diphenyl- <i>p</i> -phenylene oxide)) Hydrophobic, non-polar Surface: $\sim 35 \text{ m}^2/\text{g}$ [39]	Mid volatiles and semi-volatiles ca. C6–C26 (e.g. aromats, alcohols, terpenes), Metabolomics Low water retention
Tenax GR	Dual-mode	Graphite-modified Tenax (Tenax TA + 10% graphite powder) Hydrophobic to low amphiphilic, low polar Surface: $\sim 35 \text{ m}^2/\text{g}$ [40]	Mid volatiles, semi-volatiles and some low volatiles ca. C6–C25 (e.g. aromats, halogenic compounds) Mid water retention
Carbosieve SIII	Adsorption	Carbon molecular sieve Hydrophilic, polar Surface: $\sim 900 \text{ m}^2/\text{g}$ [39]	Very volatile compounds ca. C2–C6 (e.g. methanol, formaldehyde), strong adsorption of very polar analytes High water retention
Carboxen 1000	Adsorption	Carbon molecular sieve Hydrophilic, polar, more microporous than Carbosieve SIII Surface: $\sim 1000 \text{ m}^2/\text{g}$ [39]	Very volatile compounds ca. C2–C5 (e.g. acetaldehyde, ethanol, acetone), strong adsorption of very polar analytes High water retention
Carpack C	Adsorption	Graphitized carbon black Hydrophobic, non-polar Surface: $\sim 50 \text{ m}^2/\text{g}$ [39]	Mid volatiles ca. C5–C12 (e.g. aromats, aldehydes, ketones) Low water retention
Tenax TA/ Carboxen 1000 (Bottom/ Top, 1:1)	Overall dual-mode	Combination of polymer + carbon molecular sieve Hydrophobic/hydrophilic, non-polar/polar	Volatile range ca. C2–C25 High water retention
Tenax TA/ Carbosieve SIII (Bottom/ Top, 2:1)	Overall dual-mode	Combination of polymer + carbon molecular sieve Hydrophobic/hydrophilic, non-polar/polar	Volatile range ca. C2–C25 High water retention
Tenax GR/ Carbosieve SIII (Bottom/ Top, 1:1)	Overall dual-mode	Combination of graphite-modified polymer + carbon molecular sieve Hydrophobic/hydrophilic, rather polar	Volatile range ca. C2–C25 High water retention
Carpack C/ Carbosieve SIII (Bottom/ Top, 2:1)	Adsorption	Combination of two carbon materials Hydrophobic/hydrophilic, rather polar	Volatile range ca. C2–C12 Mid water retention

Henry's law dissolution) into the polymer matrix. Absorption is typically linear with analyte concentration and can be expressed as follows [42–44]:

$$c_{\text{abs},i} = k_{D,i} c_g$$

where $c_{\text{abs},i}$ is the absorbed concentration of compound i , c_g is the compound concentration in the gas phase and $k_{D,i}$ is the Henry's law dissolution coefficient of compound i from the gas phase into the sorbent

pores.

2.2.3. Dual-mode sorption

Many porous polymeric materials exhibit absorption and adsorption mechanisms simultaneously. Their combined behavior can be described by the dual-mode sorption model [43,44]:

$$c_s = k_D c_g + \frac{C_L b c_g}{1 + b c_g}$$

Where c_s is the total sorbed concentration, C_L is the saturation capacity of the Langmuir sites and b is the affinity constant.

2.2.4. Influence of vacuum on sorption

Vacuum reduces the total and partial gas pressure, enhancing diffusion and convection within the HS and accelerating analyte transport toward the sorbent surface. The applied pressure gradient reduces the thickness of the boundary layer surrounding the sorbent and increases gas-phase mass transfer, promoting faster sorption kinetics [25, 34]. This accelerates analyte transport to the sorbent, particularly for SVOCs that are diffusion-limited under atmospheric pressure.

2.2.5. Static vs. dynamic vacuum extraction

Static (e.g. Vac-HS-SPME) and dynamic vacuum HS microextraction methods (V-ITEX) differ in their procedure and each has advantages and disadvantages (see Fig. 1). In static HS extraction, the sample is equilibrated at fixed conditions and a defined HS portion is sampled once. The extraction is therefore essentially equilibrium-based and non-exhaustive. In dynamic HS extraction, a continuous gas flow permanently transports analytes to the sorbent phase, so that the sample-HS equilibrium is repeatedly shifted and an exhaustive transfer becomes possible [5]. In this context, exhaustive extraction refers to conditions in which the analyte present in the HS is completely transferred to the sorbent during the extraction process, approaching quantitative removal under the applied experimental conditions rather than relying solely on equilibrium partitioning [45]. V-ITEX can be classified as a dynamic HS microextraction technique, as analyte transport toward the sorbent is controlled by continuous vacuum-induced gas-phase renewal and convective mass transfer rather than equilibrium partitioning (see Fig. 1).

Based on the theoretical findings, static vacuum HS microextractions can be described as follows:

- Vacuum accelerates equilibration.
- Extraction is equilibrium-based and non-exhaustive.
- VOCs may dominate the HS composition.

Whereas for dynamic vacuum HS microextraction the following keypoints can be stated:

- Continuous gas flow through the sorbent enables constant re-equilibration (Le Chatelier's principle).
- The system approaches exhaustive extraction.
- SVOCs benefit most strongly from vacuum-enhanced re-equilibration.
- VOCs may show reduced retention if sorbent affinity is low.

3. Principle of V-ITEX

3.1. General workflow

As demonstrated by the theoretical chapters, microextractions are more efficient at reduced pressure, particularly with exhaustive methods such as ITEX. This forms the basis of V-ITEX.

Originally developed by Fuchsmann et al., in 2019 [28], V-ITEX was patented in 2020 [46] and commercialized by Gerstel (Gerstel, Mülheim

an der Ruhr, Germany) in 2025. The main difference from the previous ITEX technology lies in the extraction principle. Rather than performing multiple draw-eject cycles, V-ITEX uses a continuous vacuum on the sample vial to generate a gas flow through the sorbent bed.

The V-ITEX module consists of a gas-tight syringe containing a commercially available ITEX trap packed with a sorbent material. The syringe is connected to the sample vial via an integrated needle. For analysis, the sample is sealed in a glass vial with a vacuum-tight polytetrafluoroethylene (PTFE)-butyl crimp cap (tested in Ref. [28]) and placed in the autosampler rack. During incubation of the sample in the heating and stirring module, the ITEX trap is pre-cleaned at the supplier recommended temperature and duration under a nitrogen purge. After conditioning, the needle pierces the vial septum, and the vacuum is applied for a duration according to the method parameters. When the vacuum is applied, HS gas is drawn through the trap, and the analytes are retained by the sorbent. Any non-retained gas leaves the extraction system. The vacuum level (2-1013 mbar) of the vacuum pump is controlled by the dedicated software. The system enables temperature control of the trap, thus, extractions can be conducted at moderate temperatures, while cleaning and desorption are performed at elevated temperatures. Following extraction, optional steps for removing water from the autosampler pipes and/or the ITEX trap can be applied. The analytes are thermally desorbed in the GC inlet using a predefined desorption flow rate.

The extraction process is fully automated and reproducible, as the vacuum level and extraction parameters are electronically controlled.

3.2. Valves and flow paths

As shown in Figs. 2 and 3 the valve control system comprises two electronically actuated valves (valve 1 and valve 2), a purge gas valve and a syringe plunger in conjunction with syringe barrel in the V-ITEX module. These components enable multiple flow paths to be selected and are central to the operation of the V-ITEX module. Valve 1 controls the routing between the purge gas (N_2), the syringe, and the vacuum pump. Valve 2 controls the routing between the Electronic Pressure Control (EPC), inlet and the syringe. The purge gas valve regulates whether the purge gas is supplied or not. Although the syringe plunger is not technically a valve, gas enters through the small hole in the syringe barrel and the position of the plunger controls whether gas flows via the trap or leaves above the plunger. Switching these valves in a coordinated manner enables the following functional modes to be executed sequentially: extraction, trap drying, pipe purge, desorption and cleaning.

During extraction (see Fig. 2, flow path A), valve 1 connects the syringe to the vacuum pump. The gas flows through the syringe and trap, then through the extraction device tubing over valve 1 in the vacuum hose and out of the pump. This generates a pressure gradient that draws HS gas through the ITEX trap. The trap is typically operated at temperatures near to room temperature (30-40 °C), the purge gas supply is closed, and valve 2 maintains an open flow-through configuration toward the GC inlet.

Another flow path (not shown in figures) purges the extraction device tubing and functions like path B, except that the syringe plunger is down and gas leaves above the plunger. This enables purging of the extraction device tubing without connecting the syringe or trap, thereby preventing the accumulation of residual moisture or analytes. After extracting aqueous samples, a water-removal step can be applied to dry the trap (Fig. 2, flow path B). In this mode, valve 1 directs the purge gas through the extraction device tubing and over the trap, while valve 2 remains in the same flow-through configuration as during extraction. The trap temperature is usually set to the extraction temperature or slightly higher than during extraction to support efficient drying.

For thermal desorption and sample introduction into the Programmed Temperature Vaporization (PTV) injector, here a cooled injection system (CIS4, Gerstel, Mülheim an der Ruhr, Germany) is used.

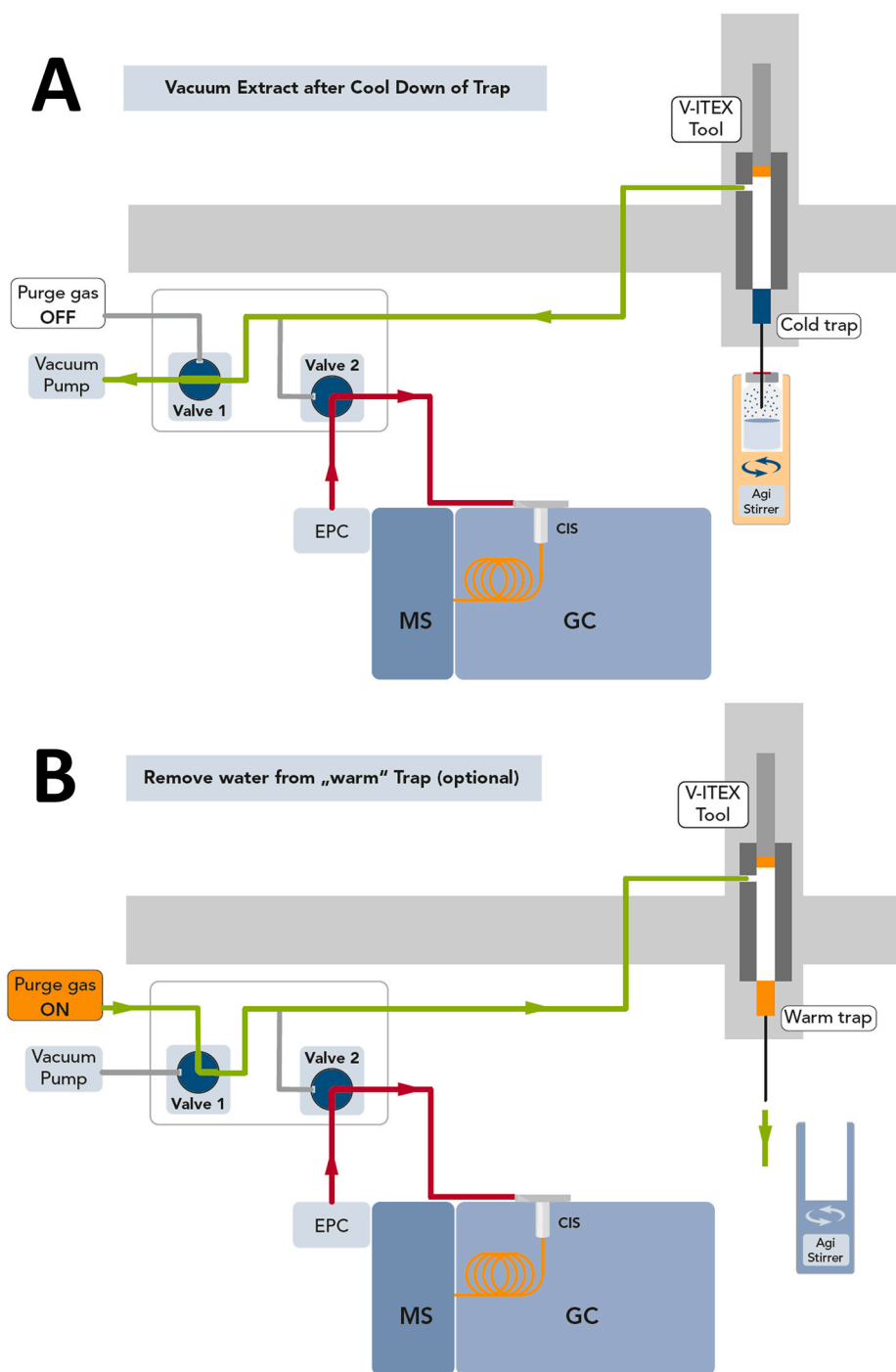

Fig. 2. Overview of flow paths for extraction (A) and water removal (B) in V-ITEX operation. Source: Gerstel.

Valve 1 is closed and the purge gas is turned off (Fig. 3, flow path C). Valve 2 then directs the carrier gas flow, which is controlled by the CIS EPC, through the extraction device tubing and over the trap for analyte desorption. The trap temperature is typically elevated to 280-300 °C. The desorption gas flow rate is defined in the instrument control software.

Trap cleaning after desorption is performed as shown in Fig. 3, flow path D. The valves operate in the same configuration as during water removal, but the trap is maintained at high temperature (typically 280-300 °C) to remove any residual compounds from the sorbent material.

3.3. Improvements from prototype to current system configuration

As shown in Fig. 4, several refinements were implemented in the V-ITEX system during the transition from the prototype to the current system configuration. These modifications primarily relate to software integration, vacuum control and pneumatic layout.

One significant change was the integration of the autosampler control software (Maestro, Gerstel GmbH & Co. KG, Mülheim, Germany) into the GC-MS environment (MassHunter, Agilent, Santa Clara, USA). This integration allows for control of the instrument, including CIS inlet control and sequence setup, within a single user interface. As a result, the V-ITEX extraction workflow, inlet operation, and GC-MS analysis

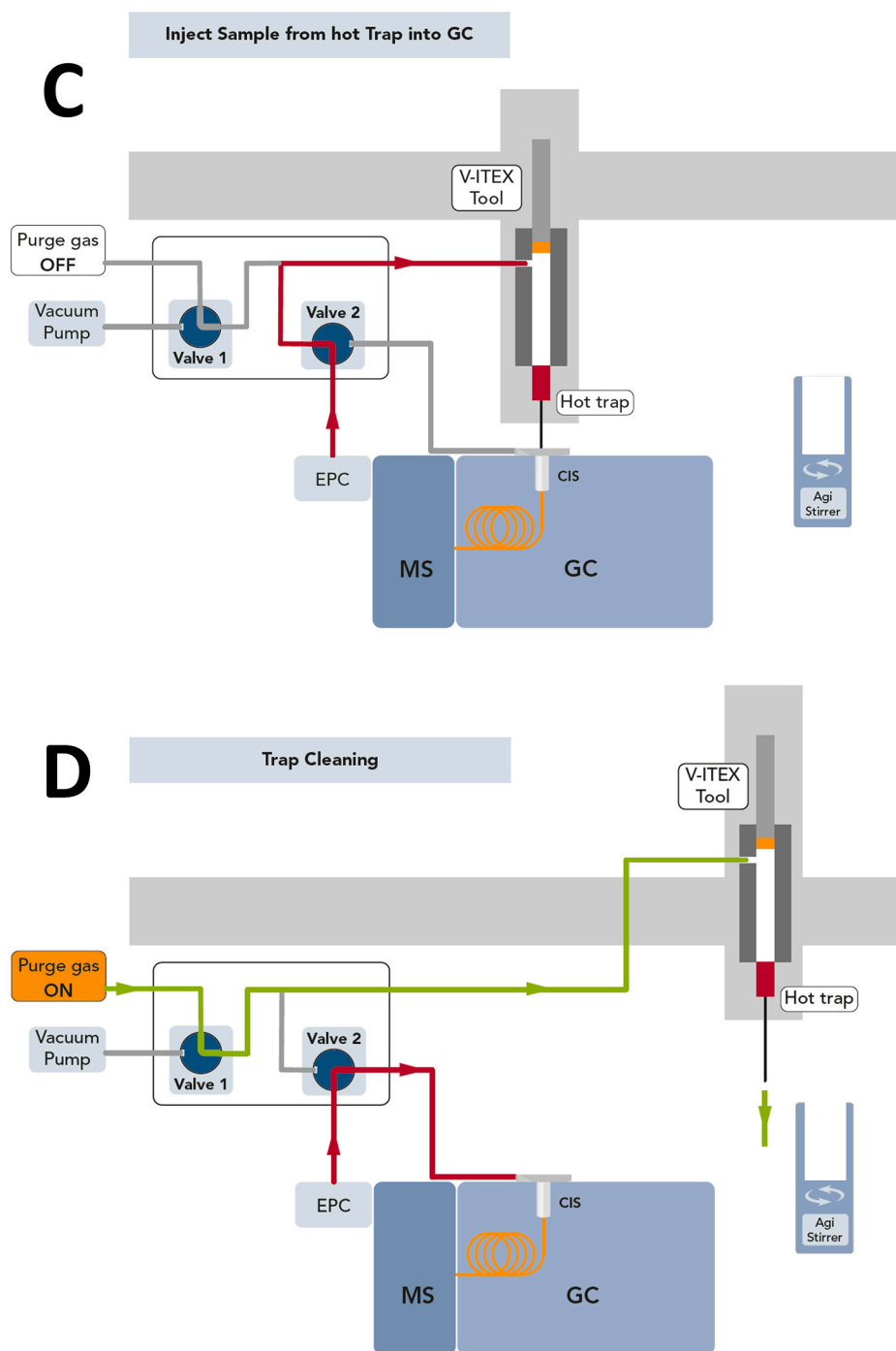

Fig. 3. Overview of flow paths for thermal desorption into the injector (C) and trap cleaning (D) in V-ITEX operation. Source: Gerstel.

can be synchronized within a single acquisition sequence.

Additionally, the vacuum system was redesigned to enable full automated operation. The prototype described in Ref. [28] used a vacuum pump, that had to be operated manually (V-300, Büchi Labor-technik, Flawil, Switzerland). The current version uses a vacuum pump (PC 3001 Vario Select, Vacuubrand, Wertheim, Germany) that is fully controlled via the acquisition software. This allows automated activation and regulation of the vacuum level during extraction and improves the reproducibility.

The pneumatic connection between the current ITEX module and the autosampler no longer contains the frit found in the classic ITEX tool because it restricted airflow under vacuum.

The pneumatic layout has also been simplified. The CIS EPC, which is platform-independent, controls the carrier gas flows and enables the simple transfer of the pneumatics method between GC-MS systems from different vendors. The internal GC EPC is disabled. This eliminates the need for modifications to the original GC inlet hardware and minimizes dead volumes in the flow path, thereby improving system stability.

Finally, the two switching valves have been integrated into a compact V-ITEX module housing, replacing the openly mounted valve assembly used in the prototype (Fig. 4). Enclosing of the valve assembly in a dedicated V-ITEX module primarily consolidates and integrates it mechanically.

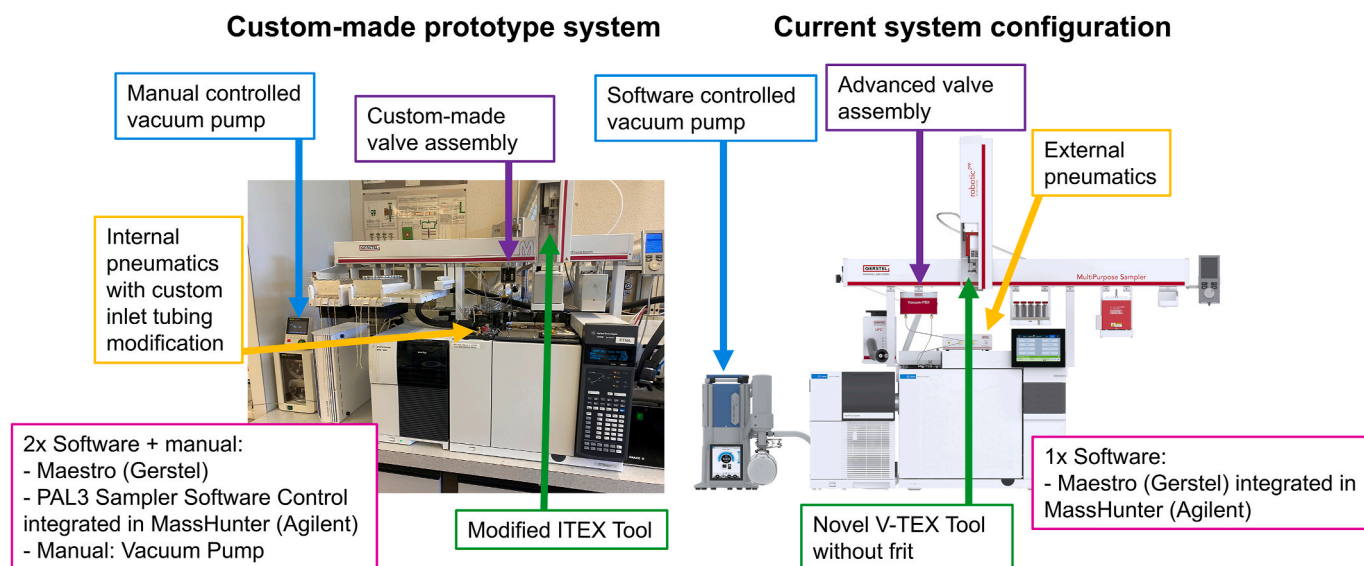

Fig. 4. Visualization of the custom-made prototype system and the current system setup with the improvements made. Parts of the figure were provided by Gerstel with permission.

4. Troubleshooting and best practices

4.1. Sample preparation

V-ITEX is compatible with a wide variety of matrices, including aqueous solutions, organic solvents, semi-solids, powders, and dry materials. For solid or powdered samples, direct weighing into the vial is usually sufficient. However, the highest repeatability is generally achieved when samples are homogenized prior to analysis. For heterogeneous solids, such as cheese, homogenization can be achieved by cutting the material into small pieces, freezing them with liquid nitrogen, and pulverizing them using a blender or food processor [47]. This approach allows for the preparation of multiple comparable replicates from a single bulk sample.

Highly inhomogeneous liquids can benefit from freeze-drying to generate a more uniform, highly-concentrated powder for analysis. This strategy has produced reliable results in the analysis of microalgae [48] and a faba-bean-based matrix with strong settling behavior (unpublished data). Since V-ITEX typically operates with minimal modification of the native matrix, standard addition or matrix-matched remains the preferred calibration approach for quantitative studies [49]. This approach effectively compensates for matrix-specific partitioning effects and enhances quantitative robustness, particularly in food and biological samples. However, compared to external calibration in solvent, standard addition typically requires larger sample volumes and multiple spiked aliquots, which may increase analytical workload and reduce sample throughput. The choice between calibration strategies should therefore balance robustness against resource availability and sample amount.

When solvent extracts are analyzed, solvent selection requires careful consideration, as solvents can compete with analytes for sorption on sorbents. In practice, acetonitrile is often preferable to methanol, while halogenated solvents such as dichloromethane should be avoided due to potential adverse effects on trap materials and inlet liners.

Since reduced pressure can increase outgassing from vial caps, septa, and glassware, preheating these components can be applied if background contamination becomes apparent. Running vial blanks is advisable to monitor background signals. The utilized vial incubation temperature on the autosampler is typically 40–60 °C, but temperatures up to approximately 90 °C are feasible. Incubation can be performed in agitator or heatex module. However, incubation above 100 °C may lead to excessive internal pressure, which can cause the vial septum to

expand and hinder vial transport on the autosampler. It can also cause the vial to explode. If higher temperatures are required, septa and caps must be selected or modified to withstand increased pressure, and they must be tested carefully beforehand.

4.2. Extraction

4.2.1. Extraction time

In V-ITEX, extraction time is a primary optimization parameter because the process is largely governed by HS mass transfer and sorbent uptake kinetics rather than by a single equilibrium partitioning step.

Depending on analyte volatility and sorbent affinity, V-ITEX may operate either in a pre-equilibrium state or approach an exhaustive state. In the pre-equilibrium state, analyte signal increases approximately proportionally with extraction time, reflecting continuous mass transfer from the sample phase to the HS and subsequent sorption. As extraction proceeds, readily transferable analyte fractions in the HS become depleted, and re-establishment of equilibrium between sample phase and HS can become rate-limiting. Under such conditions, extending extraction time results in diminishing signal gains and may eventually lead to a plateau. For weakly retained analytes, prolonged vacuum exposure can further promote partial desorption from the sorbent, resulting in plateauing or decreasing responses.

Practically, extraction times should be optimized using a short time-profile experiment (e.g., 2, 4, 6, 8, 10 min by using a quality control sample or similar) and evaluated separately for representative compound classes of interest. A plateau in peak areas indicates that longer extraction times do not improve recovery and may instead increase the risk of undesired co-extraction (e.g., water) or breakthrough of weakly retained analytes (see Fig. 5). For targeted quantitative methods, time selection should additionally consider robustness: operating slightly below the plateau typically improves repeatability while maintaining high enrichment efficiency.

4.2.2. Extraction temperature

Extraction temperature strongly influences V-ITEX performance, as it simultaneously affects phase partitioning, and sorbent interactions. Increasing temperature generally enhances analyte transfer into the HS by increasing Henry's law constants and accelerating mass transfer kinetics, which is particularly beneficial for semi-volatile compounds. However, elevated temperatures may also reduce sorbent affinity, thereby increasing the risk of premature desorption or breakthrough. In

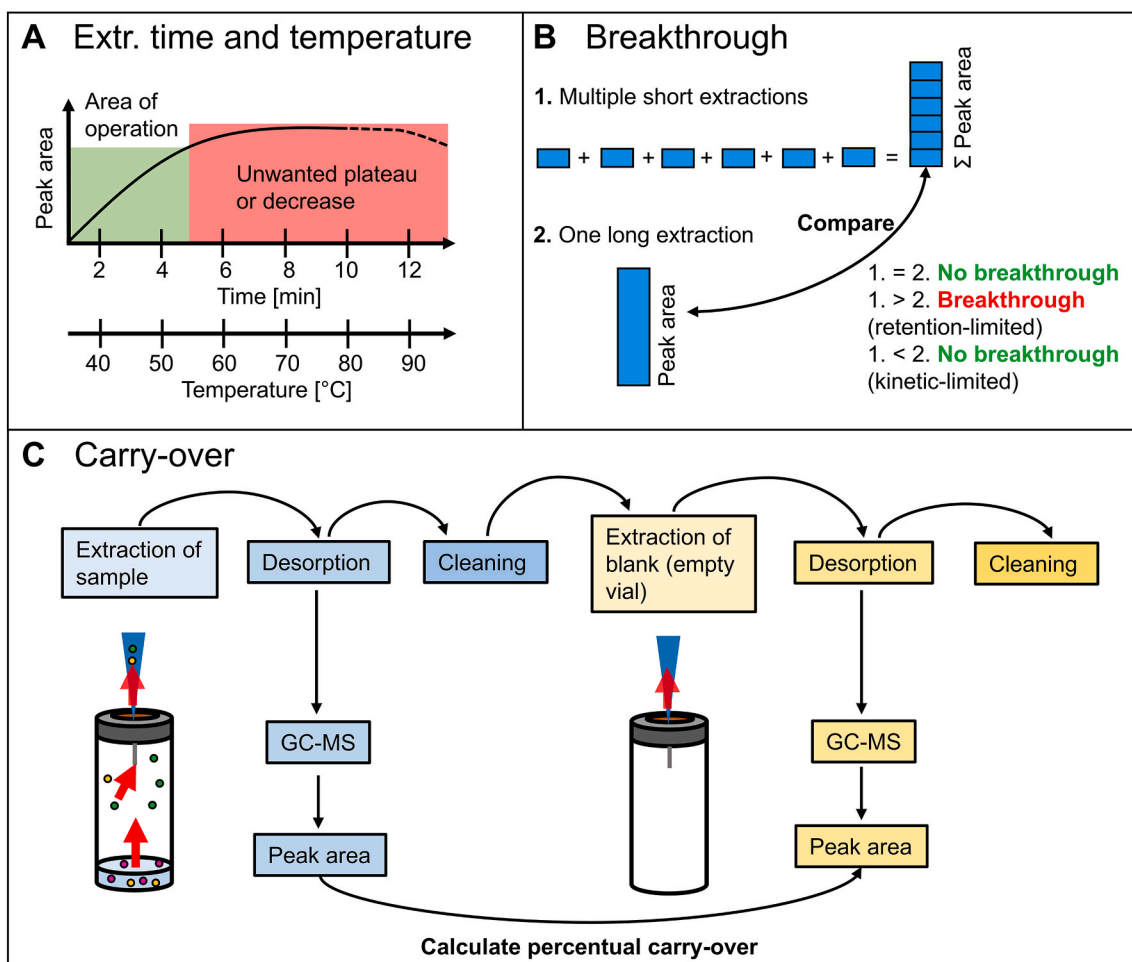

Fig. 5. Experimental strategies for evaluating key extraction parameters in V-ITEX. (A) Schematic illustration of extraction time and temperature optimization, highlighting the identification of operating regions. (B) Conceptual approach for assessing sorbent breakthrough by comparing multiple short extractions with a single long extraction of equivalent total duration. (C) Workflow for carry-over evaluation, illustrating sequential analysis of a sample followed by a blank vial to quantify residual analyte signals and calculate percentage carry-over.

addition, higher temperatures promote the co-transfer of water and undesired matrix compounds, potentially affecting chromatographic stability and trap lifetime.

Extraction temperature should be optimized by systematic variation while keeping extraction time constant, analogous to the time-profile approach described before (see Fig. 5). In practice, moderate extraction temperatures (typically 40–60 °C) provide robust performance for most matrices, while higher temperatures are also feasible but should be evaluated in terms of breakthrough. As the pressure in the vial is constantly kept low due to the extraction procedure, the risks mentioned for vial incubation at high temperatures do not apply here.

4.2.3. Breakthrough

Breakthrough describes the incomplete retention of analytes on the sorbent bed, resulting in partial loss of compounds that pass through the trap during extraction. In V-ITEX, breakthrough is governed by the interplay of phase partitioning, sorbent affinity, trap capacity, extraction temperature, and the vacuum-induced gas flow rate. Under reduced pressure, enhanced mass transfer and continuous HS renewal increase analyte flux toward the sorbent, which can challenge retention particularly for highly volatile or weakly interacting compounds.

Practical assessment of breakthrough can be performed without hardware modification by comparing a single continuous long extraction (e.g. 1 × 10 min) with multiple short extractions of identical total duration (e.g. 10 × 1 min), including intermediate desorption steps (see Fig. 5). If the cumulative signal of repeated short extractions exceeds

that of a single long extraction, insufficient retention during prolonged vacuum exposure and therefore breakthrough is likely (retention-limited). If both approaches yield comparable responses, breakthrough is unlikely under the applied conditions. Conversely, if a single continuous extraction provides a higher response than the sum of short extractions, analyte uptake is primarily limited by mass-transfer kinetics rather than sorbent capacity, indicating sufficient retention (kinetic-limited).

4.2.4. Carry-over

Carry-over refers to the unintended transfer of analytes from one extraction cycle to subsequent analyses due to incomplete desorption or residual adsorption within the trap, syringe, tubing, or inlet liner. Carry-over behavior in V-ITEX is expected to be comparable to that observed in conventional ITEX, as trap conditioning is performed using a similar thermal desorption procedure. In V-ITEX, carry-over is most likely for high-boiling compounds or compounds with high sorbent affinity. Under vacuum-enhanced extraction conditions, large analyte fluxes and exhaustive transfer may increase sorbent loading, thereby elevating the risk of incomplete thermal desorption.

Practical diagnostics of carry-over should be incorporated into routine method validation. The most direct assessment consists of performing solvent or empty-vial blank runs immediately after samples and monitoring residual target analytes (see Fig. 5). Persistent signals in blank runs indicate incomplete desorption or system contamination.

Mitigation strategies include increasing trap cleaning times,

increasing cleaning temperature (within sorbent stability limits), optimizing desorption flow, desorption duration and desorption temperature.

In cases of very persistent carry-over, an intensified cleaning approach may be considered. Previous investigations with SPME Arrow have shown that incorporating a short chemical cleaning step prior to thermal desorption cycles can markedly reduce analyte carry-over [50]. Applied to V-ITEX, this may involve drawing the HS of a trap-compatible solvent under vacuum for a short duration (e.g. 30 s), followed by the general high-temperature conditioning step. While effective, such procedures increase method complexity and solvent consumption and should be reserved for demanding applications with severe carry-over.

4.2.5. Matrix-dependent considerations

Matrix properties substantially influence extraction efficiency and method robustness in V-ITEX and should therefore be considered during method development. Aqueous samples transfer substantial amounts of water into the sorbent and extraction device tubing. Dedicated water-removal steps are therefore essential to avoid damaging the GC column and maintaining chromatographic performance. For samples with sufficiently high analyte concentrations, small volumes (<200 μL) are recommended, because they often dry completely within 5-10 min under vacuum, enabling exhaustive analyte transfer. In contrast, organic solvents readily volatilize, so extraction times of ~ 5 min are generally adequate. If the solvent adversely affects chromatographic separation, brief purge or drying of the trap can mitigate these effects. Larger sample amounts may increase water transfer and can require longer extraction or additional drying steps depending on matrix properties and vial geometry. Typical sample amounts used in published V-ITEX studies are summarized in Table 3, illustrating the range of matrices and sample quantities reported for different applications.

Consistent sample volumes are essential for comparable HS conditions across samples. For samples that occupy more than half the vial's volume, placing sterile gauze on top of the material can prevent foam or boiling droplets from entering the trap during vacuum extraction [49].

When dry or solid samples demonstrate inadequate sensitivity, the extraction process can be enhanced by adding small quantities of ultrapure water or solvent to the sample. This creates a solvent-assisted extraction condition which improves mass transfer.

4.2.6. System integrity and operational robustness

Reliable V-ITEX performance depends strongly on system tightness and component integrity; however, it should be noted that implementation requires dedicated modular hardware with coordinated vacuum and valve control. Even minimal leaks cause preferential suction of ambient air rather than HS gas through the trap, resulting in loss of sensitivity. When analytical sensitivity decreases, the GC-MS system and the entire extraction module, including the vacuum pump's performance and seal integrity should be evaluated.

Teflon-based extraction device tubing may reduce adsorption effects and improve long-term cleanliness compared with polypropylene or polyvinyl chlorid alternatives. Because water condensation and persistent analytes (e.g. dichloromethane) can accumulate in the vacuum pump lines, the tube-cleaning step should therefore be performed regularly.

All commercially available ITEX traps are compatible with V-ITEX. Using a vacuum provides an additional cleaning effect, extending the lifetime of the trap to approximately 5000 extraction cycles. However, trap lifetime depends on the matrix analyzed. During extraction, the trap temperature should be slightly lower than the syringe temperature to prevent condensation within the syringe body. Strong lateral shaking (e.g. agitator) during extraction should be avoided, as it may cause deformation of the needle, whereas gentle axial agitation (e.g. heatex) is compatible.

4.3. GC-MS analysis

Although desorption into a split/splitless injector is possible, it often results in broader chromatographic peaks, especially at the beginning of the run. Therefore, use of a CIS operating at -10 to 10 $^{\circ}\text{C}$ is recommended. Previous tests with N_2 as the desorption gas revealed that it can cause ion suppression for the low-boiling compounds and that it takes several minutes for the N_2 to leave the column. Carrier gas is now preferred for desorption. Typical desorption flow rates range from 40 to 400 mL min^{-1} depending on the application. The CIS liner contains a packed sorbent bed, that may become compacted over time and restrict flow, leading to abnormal pressure readings despite an absence of leaks.

Introducing water via the trap can negatively impact GC and MS performance. Adequate water-removal routines, proper trap conditioning, and careful monitoring of background levels help preserve chromatographic stability and mass spectral quality.

5. Application fields of V-ITEX

Since its introduction, V-ITEX has been applied in many analytical fields. The technique has been used to extract VOCs and SVOCs from liquid, semi-solid and dry matrices, and has been coupled with GC-MS-based qualitative and quantitative workflows. Fig. 6 shows exemplary chromatograms of five different matrices: cheese, wine, urine extract, serum extract and algae. These chromatograms demonstrate the applicability of V-ITEX to various matrices. Table 3 lists the 19 published studies that have used V-ITEX since its introduction in 2019. The technique has primarily been applied to small sample sizes (typically <500 mg or <150 μL).

Early applications of V-ITEX focused on food and dairy systems, where it was used to study off-flavor formation and aroma distribution in milk and cheese matrices [47,49,63]. Subsequent studies expanded its use to microbial and fermentation systems, enabling metabolomic investigations of bacterial strains, co-cultures and microalgae [48,52,53,57,62,65]. In addition to biological applications, V-ITEX has been employed for compositional analyses, such as the quantification of SVOCs residues, including 1,4-dichlorobenzene and thymol, in beeswax [54].

Beyond these analyses, it has further been used in human metabolomics to study biological fluids such as urine, serum, plasma, and exhaled breath, revealing diet-dependent and metabolic fingerprints [51,55,56,59]. More recently, the scope of V-ITEX has extended to profiling the volatile metabolites of exhaled breath, urine, serum, blood and ruminal fluid, offering a route for monitoring metabolic and nutritional status of dairy cows [58,60,61,64,66]. These metabolomics studies indicate that V-ITEX can extract volatile metabolites from highly aqueous and low-concentration matrices without additional derivatization. However, in cases where the sample amount was limited, it was necessary to use solid-phase extraction (SPE) as a preconcentration step.

Another application of V-ITEX has been its use as a preconcentration step for GC coupled to olfactometry and MS (GC-O-MS). In this context, V-ITEX efficiently traps odor-active compounds under mild thermal conditions, providing enriched extracts suitable for sensory detection. This approach has been demonstrated in dairy systems [49] and several wines (unpublished data). Often, higher sample amounts are needed for olfactometric detection (here 4 mL), so that the large sorption phase combined with the vacuum has proven to be advantageous over SPME or classical ITEX.

6. Performance characteristics

6.1. Comparison with established headspace techniques

To position V-ITEX within the broader analytical toolbox, a comparison with commonly used HS extraction techniques is provided in Table 4. The compared techniques differ mainly in sorbent capacity,

Table 3

Overview of published applications of V-ITEX across different analytical fields, matrices, and workflows. SPE: solid-phase extraction; GC-MS: gas chromatography coupled to mass spectrometry; GC-O-MS: GC coupled to olfactometric port and MS; MRS: MRS growth medium.

Field Title	Sample amount and matrix	Analysis	Year	Author and Ref
Metabolomics/Human <i>Nutrivolatilomics of urinary and plasma samples to identify candidate biomarkers after cheese, milk, and soy-based drink intake in healthy humans</i>	150 µL urine SPE eluate (solvent MeOH); 500 µL plasma	GC-MS, qualitative non-target	2020	Fuchsmann et al. [51]
Aroma/Biotechnology <i>Formation of 3-Methylbutanal and 3-Methylbutan-1-ol Recognized as Malty during Fermentation in Swiss Raclette-Type Cheese, Reconstituted Milk, and de Man, Rogosa, and Sharpe Broth</i>	GC-O: 4 mL skim milk/MRS cultures, 4 g cheese; GC-MS: 2 mL skim milk/MRS cultures	GC-O-MS (Olfactometric detection); GC-MS, quantitative	2021	Meng et al. [49]
Metabolomics/Microbiology <i>Functional strain redundancy and persistent phage infection in Swiss hard cheese starter cultures</i>	250 mg single strain and multi-strain co-culture isolates	GC-MS, qualitative non-target	2021	Somerville et al. [52]
Aroma/Biotechnology <i>Biotechnological formation of dairy flavor inducing δ-lactones from vegetable oil</i>	100 µL extract after liquid-liquid extraction (solvent MeOH)	GC-MS, quantitative	2022	Zia et al. [53]
Product control <i>Quantitation of 1,4-Dichlorobenzene and Thymol in Beeswax Using Dynamic Headspace Vacuum Transfer in Trap Extraction Prior to Gas Chromatography-Mass Spectrometry</i>	100 µL extract after liquid-solid extraction of wax (solvent MeOH)	GC-MS, quantitative	2022	Kast et al. [54]
Metabolomics/Human <i>Serum and Urine Metabolites in Healthy Men after Consumption of Acidified Milk and Yogurt</i>	300 µL urine and serum SPE eluate (solvent acetonitrile)	GC-MS, qualitative non-target	2022	Bütikofer et al. [55]
Metabolomics/Human <i>Age-Dependent Serum Volatilomics of Milk and Yogurt Intake: A Randomized Crossover Study in Healthy Young and Older Men</i>	100 µL serum SPE eluate (solvent acetonitrile)	GC-MS, qualitative non-target	2023	Meng et al. [56]
Metabolomics/Microbiology <i>Scory2: rapid association of phenotypic multi-omics data with microbial pan-genomes</i>	250 mg yoghurt	GC-MS, qualitative non-target	2024	Roder et al. [57]
Metabolomics/Animal <i>Optimization of volatile organic compounds sampling from dairy cow exhaled breath using polymer-based solid-phase extraction cartridges for gas chromatographic analysis</i>	100 µL exhaled breath SPE eluate (solvent acetonitrile)	GC-MS, qualitative non-target	2024	Eichinger et al. [58]
Metabolomics/Human <i>Comparative analysis of feature annotation methods for SESI-HRMS in exhaled breath analysis</i>	100 µL exhaled breath condensate	GC-MS, qualitative non-target	2024	Wüthrich et al. [59]
Metabolomics/Animal <i>Usability of volatile organic compounds from exhaled breath compared with those from ruminal fluid, serum, urine, and milk to identify diet-specific metabolite profiles in lactating dairy cows</i>	100 µL of exhaled breath SPE eluate (solvent acetonitrile), ruminal fluid, serum and milk	GC-MS, qualitative non-target	2024	Eichinger et al. [60]
Metabolomics/Animal <i>Pathway mapping of exhaled volatile organic compounds associated with blood and ruminal fluid metabolites to describe the nutritional and metabolic status of lactating dairy cows</i>	100 µL of exhaled breath SPE eluate (solvent acetonitrile), ruminal fluid, blood	GC-MS, qualitative non-target	2025	Eichinger et al. [61]
Aroma <i>Analytical Mapping of Swiss Hard Cheese to Highlight the Distribution of Volatile Compounds, Aroma, and Microbiota</i>	2 g of cheese	GC-MS, semi-quantitative	2025	Tintrop et al. [47]
Metabolomics/Microbiology <i>Metabolic profiling reveals enrichment of health-related metabolites in yoghurt by variation of strain consortium</i>	250 mg yoghurt	GC-MS, qualitative non-target	2025	Christensen et al. [62]
Aroma/Biotechnology <i>How raw milk-based adjunct cultures influence microbial diversity in cheese</i>	500 mg of cheese	GC-MS, semi-quantitative	2025	Dreier et al. [63]
Metabolomics/Animal <i>Comparison of the suitability of different sampling techniques for exhaled volatile organic compounds in dairy cows</i>	100 µL of exhaled breath SPE eluate (solvent acetonitrile)	GC-MS, qualitative non-target	2025	Eichinger et al. [64]
Metabolomics/Microbiology <i>Effect of salinity on the composition of a seawater-adapted strain of Scenedesmus almeriensis</i>	25 mg of freeze-dried microalgae	GC-MS, semi-quantitative	2025	Rivera-Sánchez et al. [65]
Metabolomics/Animal <i>Exhaled aldehydes as promising compounds to describe the energy balance of lactating dairy cows on a fresh herbage-based diet</i>	100 µL of exhaled breath SPE eluate	GC-MS, semi-quantitative	2025	Eichinger et al. [66]
Aroma/Biotechnology <i>Mechanical cell disruption of the green microalga Chloroidium saccharophilum: Effects on protein digestibility and aroma profile</i>	25 mg of freeze-dried microalgae	GC-MS, semi-quantitative	2025	Kurpan et al. [48]
Aroma/Biotechnology <i>Physicochemical Characterisation of Microalgal Biomass: Paving the Way for Industrial Exploitation</i>	25 mg of freeze-dried microalgae	GC-MS, semi-quantitative	2026	Marina-Montes et al. [67]
Metabolomics/Human <i>Evaluation and optimization of SPE pre-processing combined with V-ITEX-GC-MS versus direct V-ITEX-GC-MS for urinary volatilome profiling</i>	200 µL urine; 100 µL urine SPE eluate (solvent dichloromethane)	GC-MS, semi-quantitative	2026	Tintrop et al. [68]

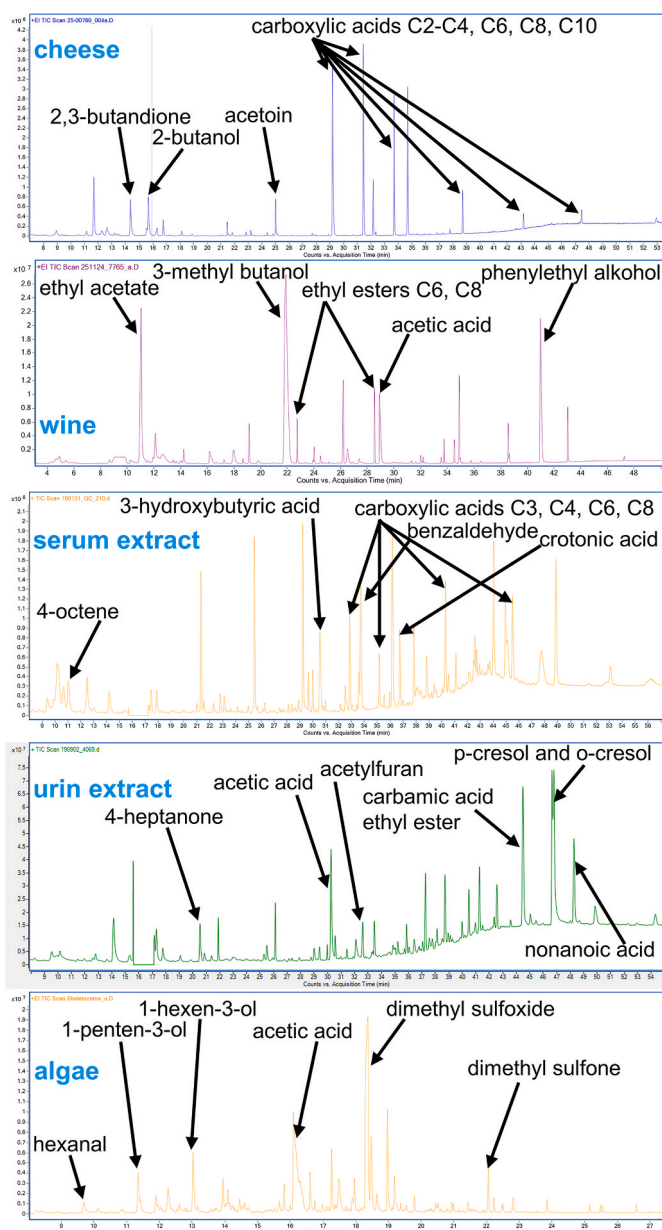

Fig. 6. Example chromatograms of V-ITEX and followed GC-MS analysis for different matrices: cheese, wine, solid-phase extraction (SPE) extract of human serum, SPE extract of human urine, and freeze-dried microalgae. A selection of identified peaks has been labeled.

automation level, and extraction principle.

Sorbent capacity varies substantially between techniques, ranging from approximately 0.5-30 mg in SPME variants to 10-300 mg in dynamic techniques such as ITEX, DHS and purge-and-trap. This parameter directly influences enrichment potential, sensitivity and the ability to handle samples with higher analyte concentrations or larger sample amounts. On the contrary, higher capacity sorbents often require longer cleaning times than low-capacity sorbents. Automation is another key practical factor. Techniques such as HS-SPME, ITEX, DHS, purge-and-trap, and V-ITEX can be fully integrated into autosampler-based workflows, whereas approaches like TF-HS-SPME or vacuum-assisted HS-SPME require manual handling steps. Differences also exist in matrix compatibility. For example, purge-and-trap is primarily designed for aqueous samples, while other techniques such as HS-SPME, ITEX, and V-ITEX can be applied to both aqueous and solid matrices. In addition, V-ITEX can accommodate solvent-containing samples because volatile

solvents can be removed under reduced pressure prior to analyte trapping. Static microextraction approaches such as HS-SPME, HS-SPME Arrow, HS-TF-SPME and Vac-HS-SPME rely on equilibrium partitioning, whereas dynamic techniques such as DHS, purge-and-trap, ITEX, and V-ITEX actively transfer analytes to the sorbent phase, often enabling higher enrichment. Vacuum-assisted approaches further enhance analyte transfer by reducing system pressure and increasing mass transfer rates. These differences illustrate how individual techniques address different analytical requirements and sample types.

6.2. Quantitative performance and analytical robustness

The performance of V-ITEX was systematically evaluated in the original methodological study published in 2019, demonstrating that vacuum-assisted extraction substantially enhances analytical sensitivity compared with classical ITEX and HS-SPME. Reported signal increases of up to approximately 450 for selected VOCs extracted with V-ITEX [28]. In the same study, the most effective sorbent for the targeted analytes was a mixed-bed trap consisting of Tenax TA/Carbosieve III. In contrast, subsequent metabolomics-oriented work utilizing ITEX to urine samples without SPE pre-concentration identified pure Tenax TA as the most suitable material (unpublished data). These findings confirm that sorbent selection should be tailored to the matrix characteristics and the chemical class of interest.

V-ITEX's quantitative performance has also been demonstrated in applications involving SVOCs. For determining 1,4-dichlorobenzene and thymol in beeswax, V-ITEX achieved limits of detection (LODs) of 0.015 mg/kg and 0.10 mg/kg, respectively. Thymol required quantification over a broad concentration range (0.25-250 mg/kg) using an external calibration spanning 0.025-20 mg/L, with linearity coefficients (R^2) > 0.9978 [54].

In a separate quantitative study, four key metabolites: 2-methylbutanal, 3-methyl-1-butanol, α -ketoisocaproic acid methyl ester, and α -hydroxyisocaproic acid methyl ester; were quantified in microbiological systems. The reported calibration ranges extended from 0 to 2500, 0-1'250, 0-18'021, and 0-73'094 μ g/L, respectively. LODs were 1.7, 0.2, 8, and 58 μ g/L, demonstrating both wide quantification ranges and adequate sensitivity for low-abundance compounds. Calibration based on standard addition directly in MRS broth and reconstituted skim milk showed no significant matrix effects affecting linearity, and all calibration curves exhibited R^2 values > 0.994 [49].

Taken together, these results demonstrate that V-ITEX exhibits linear response behavior across a wide range of matrices and concentration levels making it suitable for routine quantitative applications. External calibration is feasible when extraction efficiency remains proportional to analyte concentration and matrix effects are minimal. The reported relative standard deviation values (RSDs) of replicates in the studies summarized in Table 3, typically ranged between 1 and 20%, with occasional higher values ranging from 20 to 40% depending on the complexity of the matrix and the characteristics of the analyte.

6.3. Chemical space coverage of V-ITEX-GC-MS applications

To complement the performance data, a comprehensive chemical space analysis was conducted on VOCs and SVOCs identified in randomly selected 336 samples across the 19 published studies summarized in Table 3 together with additional internal unpublished datasets resulting in 49 different studies carried out from 2019 to 2025 using V-ITEX-GC-MS. Unknowns Analysis (version 11.1, Agilent, Basel, Switzerland) was performed with a minimum match factor of 80% spectral comparison to the commercial NIST23 database. A total of 3'978 compounds were putatively identified in different matrices namely alcoholic and non-alcoholic beverages, vegan and novel foods, microbial cultures, meat products, human and animal metabolomics, honey, dairy products, bread and cereals, fruits, herbs, plants and vegetables. The compounds were structurally classified based on their Simplified

Table 4

Comparison of commonly used headspace extraction techniques for GC-based analysis of volatile compounds. Extr.: Extraction; HS: Headspace; SPME: Solid-phase microextraction; TF-SPME: Thin-film solid-phase microextraction; DHS: Dynamic headspace; ITEX: In-tube extraction; Vac-HS-SPME: Vacuum-assisted headspace solid-phase microextraction; V-ITEX: Vacuum in-tube extraction. Samp.: Sample matrix types; Aq: Aqueous; Sd: Solid; Sol: Solvent; Auto.: Automation degree; Ref.: Reference.

Technique (<i>Extr. Principle</i>)	Steps	Typical analyte ranges	Samp.	Auto.	Sorbent amount	Advantages	Limitations	Ref.
HS-SPME (Static)	-Incubation -Extraction -Desorption in the injector -Thermal cleaning	VOCs to light SVOCs	Aq, Sd	Full	0.5-1 mg	-Full automation -widely known and accepted -Applicable with standard autosamplers	-Low sorbent capacity -Fiber fragility	[1], [69]
HS-SPME Arrow (Static)	-Incubation -Extraction -Desorption in the injector -Thermal cleaning	VOCs to light SVOCs	Aq, Sd	Full	6-20 mg	-Full automation -Higher sorbent capacity than SPME -More stable than SPME	-Dedicated instrumentation needed (wider injection port)	[70]
HS-TF-SPME (Static)	-Incubation -Extraction -Desorption in the injector or TDU -Thermal cleaning	VOCs to light SVOCs	Aq, Sd	Semi	5-30 mg	-Higher sorbent capacity than SPME -Fast extraction due to thin phase	-Semi-automated -Format complicates handling	[71], [72]
DHS (Dynamic)	-Incubation -Extraction -Drying (optional) -Desorption in the TDU -Thermal cleaning	VOCs to light SVOCs	Aq, Sd	Full	100-300 mg	-Full automation -Very high sorbent capacity -Suitable for large sample volumes	-Dedicated instrumentation needed (DHS supporting autosampler)	[73]
Purge and Trap (Dynamic)	-Incubation -Purging -Extraction -Drying (optional) -Desorption in injector -Thermal cleaning	VOCs	Aq	Full	100-500 mg	-Full automation -Very high sorbent capacity -Suitable for large sample volumes	-Dedicated instrumentation needed (Purge and Trap Device)	[74]
ITEX (Dynamic)	-Incubation -Extraction (multiple cycles) -Desorption in injector -Thermal cleaning	VOCs to SVOCs	Aq, Sd	Full	10-60 mg	-Full automation -Higher sorbent capacity than SPME variants -Multiple extraction cycles	-Dedicated instrumentation needed (ITEX supporting autosampler)	[2]
Vac-HS-SPME (Static)	-Manual vacuuming -Incubation -Extraction -Desorption in injector -Thermal cleaning	VOCs to SVOCs	Aq, Sd	Semi	0.5-1 mg	-Enhanced extraction compared to HS-SPME -Applicable with standard autosamplers	-Semi-automated (vacuum must be applied manually to each vial) -Low sorbent capacity -Fiber fragility	[32]
V-ITEX (Dynamic)	-Incubation -Extraction under vacuum -Drying (optional) -Desorption in injector -Thermal cleaning	VOCs to SVOCs	Aq, Sd, Sol	Full	10-60 mg	-Full automation -Higher sorbent capacity than SPME variants -Enhanced extraction compared to ITEX	-Dedicated instrumentation (V-ITEX supporting autosampler) -Sorbent breakthrough possible	[28]

Molecular Input Line Entry System (SMILES) descriptors. Their molecular weights and topological polar surface area (TPSAs) were obtained from the ChemSpider database [75]. Functional group recognition and classification into chemical families followed the International Union of Pure and Applied Chemistry (IUPAC) prioritization rules, enabling assignment of main chemical classes.

The resulting chemical space plots (Fig. 7) reveal the distribution of the detected compounds and highlight the wide structural diversity captured using V-ITEX. Panels A and B zoom into subclasses, whereas C shows the full dataset.

TPSA was used as a parameter here, as it is frequently used in pharmaceutical research to estimate passive molecular transport across biological membranes and to predict oral bioavailability or blood-brain barrier penetration [76]. However, to our knowledge, TPSA has not yet been systematically applied within analytical chemistry to describe volatility-related behavior or extraction efficiency. TPSA was selected here as an orthogonal polarity descriptor relevant to volatility, HS partitioning, and sorbent interactions under vacuum-assisted extraction

conditions. We show that the V-ITEX configurations applied between 2019 and 2025 successfully covered a TPSA range from 0 to approximately 140 Å².

6.4. Method sustainability and greenness evaluation

To evaluate the environmental sustainability of V-ITEX, a comparative greenness assessment was performed using the AGREE [77] and AGREEprep [78] metrics in default weighing based on selected representative workflows in executed studies using direct V-ITEX and a small sample volume of 100 µL [59], direct V-ITEX and a high sample amount of 2 g [47] and SPE processing combined with V-ITEX [58,60,61,64,66]. A detailed list of settings, related estimations and comments for utilizing the evaluation tools are presented in the supporting information (SI) in Table S1.

AGREE evaluates compliance with the 12 principles of Green Analytical Chemistry, while AGREEprep focuses specifically on sample preparation aspects. As shown in Fig. 8, direct V-ITEX workflows exhibit

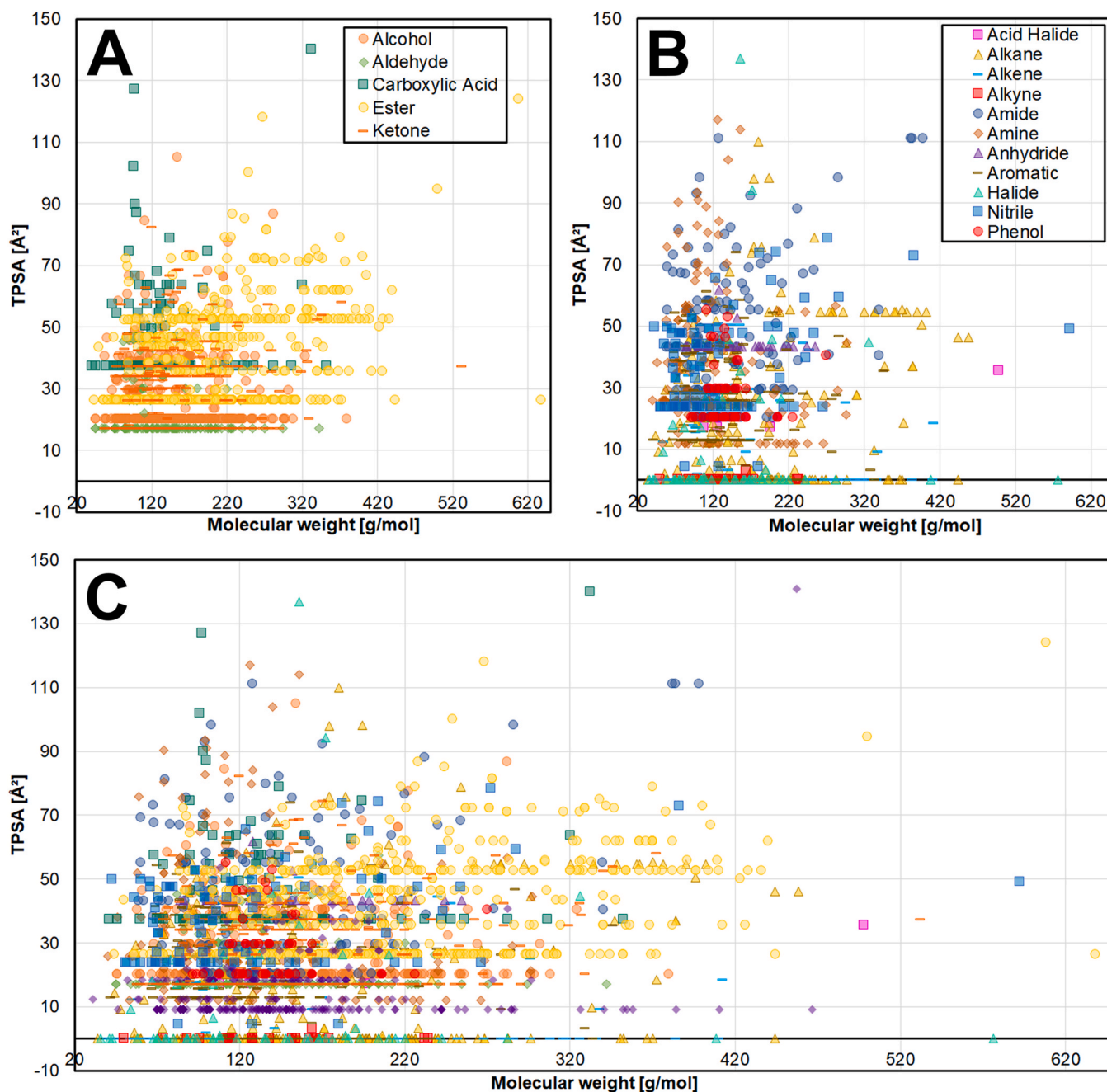

Fig. 7. Visualization of chemical space of volatile organic compounds covered by V-ITEX-GC-MS in studies conducted on different matrices namely alcoholic and non-alcoholic beverages, vegan and novel foods, microbial cultures, meat products, human and animal metabolomics, honey, dairy products, bread and cereals, fruits, herbs, plants and vegetables over the years 2019-2025. Panels A and B display zoomed-in subsets, highlighting common functional groups such as esters and alcohols (A) and less common groups such as nitrogen- and halogen-containing compounds (B). Panel C displays all groups in one figure. TPSA: topological polar surface area in \AA^2 .

favorable to moderate greenness profiles, with AGREE and AGREE prep scores of 0.78/0.61 for a method with a low sample volume and 0.71/0.51 for a method with a high sample amount. These values indicate good overall compliance with green analytical principles, mainly driven by solvent-free operation, minimal sample preparation, and full automation. The lower score observed for high sample amounts reflects the reduced miniaturization. In contrast, the combination of SPE pre-processing with V-ITEX results in a noticeably lower AGREE and AGREEprep scores of 0.56/0.17, reflecting the additional use of solvents, higher waste generation, reduced user safety, increased sample handling, manual steps, and extended workflow complexity.

Overall, these results demonstrate that V-ITEX can be considered a

relatively green sample preparation technique, particularly when applied in direct workflows without additional preprocessing. However, the integration of solvent-based steps such as SPE can significantly reduce the environmental performance and should therefore be carefully considered depending on the analytical requirements.

7. Limitations and perspectives

The V-ITEX technique has already undergone substantial technical optimization. Nevertheless, several technological and workflow aspects remain that need further refinement. Factors such as background contamination from tubing materials as well as condensation-related

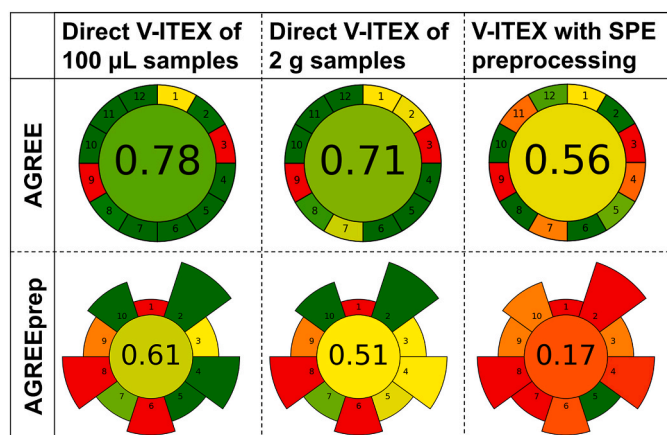

Fig. 8. Greenness evaluation of V-ITEX-based workflows using AGREE [77] and AGREEprep [78] metrics. The pictograms represent the overall compliance with the principles of green analytical chemistry (AGREE) and green sample preparation (AGREEprep), with scores ranging from 0 (low) to 1 (high). Colors represent the performance with darkgreen (very good) to red (very bad). Three workflows are compared: direct V-ITEX with a low sample amount of 100 μ L, direct V-ITEX with a high sample amount of 2 g, and SPE preprocessing combined with V-ITEX. The individual segments of each pictogram correspond to specific evaluation criteria, while the central score reflects the overall greenness performance of the respective method. (For interpretation of the references to colour in this figure legend, the reader is referred to the Web version of this article.)

water effects under vacuum conditions require more systematic investigation. These water-related issues may be especially relevant when using hydrophilic or polymer-based sorbents. Further optimization may be achieved by evaluating novel sorbent materials to broaden the accessible volatility range or shaping specific properties. At the same time, the limited availability of suitable inlet liner materials highlights the need for systematic development of alternative liner compositions to minimize artifacts and improve analytical robustness. Due to the dynamic nature of V-ITEX and the increased analyte flux under reduced pressure, breakthrough represents an inherent risk, particularly for highly volatile or weakly retained compounds. Complete exclusion of breakthrough cannot be assumed a priori and requires experimental verification during method development. This characteristic distinguishes V-ITEX from purely equilibrium-based HS techniques and should be considered when targeting very volatile analytes or operating under extraction parameter extremes. Additional investigation of sample pretreatment strategies, such as salting-out or the addition of small volumes of organic solvents to solid or dry samples, may further enhance extraction efficiency for specific analyte classes without compromising matrix compatibility. The influence of sample volume on method reproducibility has not yet been systematically evaluated. Future studies could investigate whether larger sample volumes affect extraction stability or variability under vacuum conditions.

Quantitative method descriptions are reported in only a limited number of studies. In quantitative workflows, the frequent use of standard addition or matrix-matched calibration, while methodologically robust, may increase sample consumption and analytical workload compared with solvent-based external calibration.

From a green analytical chemistry perspective, direct V-ITEX approaches offer several advantages. The technique operates without extraction solvents and requires minimal sample preparation, which reduces chemical waste and handling steps. In addition, full automation enables efficient sample throughput and reproducible workflows. However, the method requires dedicated instrumentation including a compatible autosampler platform, electronically controlled valve switching, and a vacuum pump. This hardware dependency may limit accessibility in laboratories lacking appropriate modular configurations

and increases initial implementation complexity compared to simpler HS techniques such as HS-SPME. The vacuum pump introduces additional energy consumption compared with conventional static HS approaches [79,80]. The combination of SPE preprocessing and V-ITEX reduces the methods greenness and should be avoided if the direct V-ITEX approach has comparable performance.

On the analytical side, a promising direction is integrating V-ITEX with high-resolution MS platforms such as GC-TOF or GC-Orbitrap systems. These technologies offer increased sensitivity and mass accuracy, which could be particularly valuable for untargeted metabolomics workflows and the annotation of unknown compounds. Despite their widespread use in related fields, their combination with V-ITEX has not yet been systematically explored. While initial experiments coupling V-ITEX with GC-O-MS have demonstrated feasibility, the available data remain limited. Further studies targeting odor-active compounds using V-ITEX-GC-O-MS could be particularly valuable in food, aroma and sensory science.

V-ITEX shows considerable potential for a wide range of additional fields, including environmental analysis of water and soil. In such contexts, vacuum-assisted extraction may enable the enrichment of trace-level contaminants and semi-volatile pollutants. In drinking water analysis, for example, the technique could be well suited for detecting taste and odor compounds that occur at sub-ng/L concentrations and exhibit high chemical diversity. Similarly, while initial studies in human metabolomics have primarily focused on nutrition-related biomarkers, future work could extend V-ITEX to clinically relevant applications, such as the detection of disease-associated volatile biomarkers. More exploratory concepts include non-invasive or near-in-vivo applications, for example the analysis of emissions from living plants, insects, insect housings or small animals. In such cases, adjusting the applied vacuum level may balance analyte enrichment with sample or organism integrity. It should be noted that V-ITEX does not enable real-time emission monitoring of living organisms. Instead, the technique relies on short-term enclosure of the sample within a sealed vial, where emitted volatiles accumulate prior to extraction.

8. Conclusions

V-ITEX is a robust and versatile technique for the HS analysis of VOCs and SVOCs across diverse matrices. It combines vacuum-assisted transfer, sorbent trapping, and thermal control to enable efficient extraction under mild conditions with broad chemical coverage. However, it also has specific limitations that should be considered. This tutorial critically discusses the theoretical and practical aspects of the method, including thermodynamic and kinetic principles, sorption behavior, and system configuration. Key performance data and application examples demonstrate its suitability for routine and advanced workflows in food, environmental, and metabolomics research. The chemical space covered by V-ITEX, along with low sample demand, full automation, and reduced thermal requirements, supports its classification as a green, matrix-independent alternative to conventional HS techniques.

Declaration of generative AI and AI-assisted technologies in the manuscript preparation process

During the preparation of this work, the authors used generative AI tools (ChatGPT, OpenAI) to support language editing, text structuring, and the refinement of scientific formulations, as well as for the conceptual design of graphical elements for the graphical abstract. After using these tools, the authors critically reviewed, edited, and validated all content and take full responsibility for the final manuscript.

Funding

This research did not receive any specific grant from funding

agencies in the public, commercial, or not-for-profit sectors.

CRedit authorship contribution statement

Lucie K. Tintrop: Conceptualization, Formal analysis, Investigation, Software, Validation, Visualization, Writing – original draft. **Simon Wacker:** Resources, Software, Writing – review & editing. **Florian Kopiec:** Resources, Software, Visualization, Writing – review & editing. **Stefan Cretnik:** Resources, Writing – review & editing. **Pascal Fuchsmann:** Data curation, Methodology, Resources, Supervision, Writing – review & editing.

Declaration of competing interest

L.K.T, S.W. and P.F: The authors declare no personal financial interests related to the commercialization of the V-ITEX technology. The underlying patent related to the V-ITEX technology is held by Agroscope and was licensed free of charge to CTC Analytics and subsequently to GERSTEL for commercialization. Agroscope did not receive financial compensation related to the commercialization of the technology.

F.K.: F.K. is employee of Gerstel GmbH & Co. KG, the company that commercialized the instrumentation related to the V-ITEX technique described in this manuscript.

S.C.: S.C. is employee of CTC Analytics AG, the company that was involved in the commercialization of the instrumentation related to the V-ITEX technique described in this manuscript.

Acknowledgements

The authors thank Fabian Wahl, Head of the Microbial Food Systems Department at Agroscope, for his pivotal contribution to the development of the underlying patent together with Pascal Fuchsmann und Patrick Bischoff. We further acknowledge the teams at CTC Analytics and GERSTEL for recognizing the potential of the V-ITEX technology, for the fruitful scientific exchange, and for the rapid and efficient implementation of its commercialization.

Appendix A. Supplementary data

Supplementary data to this article can be found online at <https://doi.org/10.1016/j.aca.2026.345539>.

Data availability

Data will be made available on request.

References

- [1] C.L. Arthur, J. Pawliszyn, Solid phase microextraction with thermal desorption using fused silica optical fibers, *Anal. Chem.* 19 (1990) 2145–2148, <https://doi.org/10.1021/ac00218a019>.
- [2] M.A. Jochmann, X. Yuan, B. Schilling, T.C. Schmidt, In-tube extraction for enrichment of volatile organic hydrocarbons from aqueous samples, *J. Chromatogr. A* 2 (2008) 96–105, <https://doi.org/10.1016/j.chroma.2007.11.100>.
- [3] A. Sarafraz-Yazdi, A. Amiri, *Liquid-Phase Microextraction*, vol. 1, 2010, pp. 1–14, <https://doi.org/10.1016/j.trac.2009.10.003>.
- [4] M.G. Wilkinson, G. LaPointe, Invited review: starter lactic acid bacteria survival in cheese: new perspectives on cheese microbiology, *J. Dairy Sci.* 12 (2020) 10963–10985, <https://doi.org/10.3168/jds.2020-18960>.
- [5] B. Kolb, L.S. Ettre, *Static headspace-gas Chromatography: Theory and Practice*, John Wiley & Sons, 2006.
- [6] M. Kusano, M. Kobayashi, Y. Iizuka, A. Fukushima, K. Saito, Unbiased Profiling of Volatile Organic Compounds in the Headpace of Allium Plants Using an in-tube Extraction Device, vol. 1, 2016, p. 133, <https://doi.org/10.1186/s13104-016-1942-5>.
- [7] S.A. Socaci, C. Socaci, M. Tofană, I.V. Rați, A. Pinte, In-tube extraction and GC-MS analysis of volatile compounds from wild and cultivated sea buckthorn (*Hippophae rhamnoides* L. ssp. *Carpatica*), *Berry Variet. Juice* 4 (2013) 319–328, <https://doi.org/10.1002/pc.2413>.
- [8] H. Lan, J. Holopainen, K. Hartonen, M. Jussila, M. Ritala, M.-L. Riekkola, Fully Automated Online Dynamic In-Tube Extraction for Continuous Sampling of Volatile Organic Compounds in Air, vol. 13, 2019, pp. 8507–8515, <https://doi.org/10.1021/acs.analchem.9b01668>.
- [9] J. Zapata, L. Mateo-Vivaracho, R. Lopez, V. Ferreira, Automated and Quantitative Headspace in-tube Extraction for the Accurate Determination of Highly Volatile Compounds from Wines and Beers, 2012, pp. 1–7, <https://doi.org/10.1016/j.chroma.2012.01.037>.
- [10] J. Laaks, M.A. Jochmann, B. Schilling, K. Molt, T.C. Schmidt, In-Tube Extraction-GC-MS as a High-Capacity Enrichment Technique for the Analysis of Alcoholic Beverages, vol. 14, 2014, pp. 3081–3091, <https://doi.org/10.1021/jf405832u>.
- [11] W. Kaziur-Cegla, M.A. Jochmann, K. Molt, A. Bruchmann, T.C. Schmidt, In-tube Dynamic Extraction for Analysis of Volatile Organic Compounds in Honey Samples, 2022 100337, <https://doi.org/10.1016/j.fochx.2022.100337>.
- [12] J. Laaks, M.A. Jochmann, B. Schilling, T.C. Schmidt, Optimization Strategies of in-tube Extraction (ITEX) Methods, vol. 22, 2015, pp. 6827–6838, <https://doi.org/10.1007/s00216-015-8854-4>.
- [13] J. Laaks, M.A. Jochmann, B. Schilling, T.C. Schmidt, In-Tube Extraction of Volatile Organic Compounds from Aqueous Samples: an Economical Alternative to Purge and Trap Enrichment, vol. 18, 2010, pp. 7641–7648, <https://doi.org/10.1021/ac101414t>.
- [14] N.P. Brunton, D.A. Cronin, F.J. Monahan, The effects of temperature and pressure on the performance of Carboxen/PDMS fibres during solid phase microextraction (SPME) of headspace volatiles from cooked and raw Turkey breast, *Flavour Fragr. J.* 4 (2001) 294–302, <https://doi.org/10.1002/ffj.1000>.
- [15] Y. Syrgabek, M. Alimzhanova, S. Yegemova, S. Batyrbekova, Vacuum-assisted headspace-solid phase microextraction of pesticides in grape samples, *Adv. Sample Prep.* (2024) 101–123, <https://doi.org/10.1016/j.sampre.2024.100123>.
- [16] B.J. Pollo, K.L. Romero-Orejón, A.J. Marsaioli, P.T.V. Rosa, F. Augusto, Vacuum-assisted headspace solid-phase microextraction and gas chromatography coupled to mass spectrometry applied to source rock analysis, *Adv. Sample Prep.* (2022) 100001, <https://doi.org/10.1016/j.sampre.2021.100001>.
- [17] M. Beiranvand, A. Ghiasvand, Simple, low-cost and reliable device for vacuum-assisted headspace solid-phase microextraction of volatile and semivolatile compounds from complex solid samples, *Chromatographia* 12 (2017) 1771–1780, <https://doi.org/10.1007/s10337-017-3422-z>.
- [18] F. Capetti, P. Rubiolo, G. Mastellone, A. Marengo, B. Sgorbini, C. Cagliero, A sustainable approach for the reliable and simultaneous determination of terpenoids and cannabinoids in hemp inflorescences by vacuum assisted headspace solid-phase microextraction, *Adv. Sample Prep.* (2022) 100014, <https://doi.org/10.1016/j.sampre.2022.100014>.
- [19] S. Mascrez, J. Aspromonte, N.D. Spadafora, G. Purcaro, Vacuum-assisted and multi-cumulative trapping in headspace solid-phase microextraction combined with comprehensive multidimensional chromatography-mass spectrometry for profiling virgin olive oil aroma, *Food Chem.* (2024) 138409, <https://doi.org/10.1016/j.foodchem.2024.138409>.
- [20] N. Delbecque, S. Mascrez, E. Psillakis, G. Purcaro, Sub-ambient temperature sampling of fish volatiles using vacuum-assisted headspace solid phase microextraction: theoretical considerations and proof of concept, *Anal. Chim. Acta* (2022) 339365, <https://doi.org/10.1016/j.aca.2021.339365>.
- [21] A. Pateraki, E. Psillakis, Vacuum-assisted headspace solid phase microextraction for monitoring ripening-induced changes in tomato volatile profile, *J. Chromatogr. A* (2025) 465556, <https://doi.org/10.1016/j.chroma.2024.465556>.
- [22] E. Psillakis, Vacuum-assisted headspace solid-phase microextraction: a tutorial review, *Anal. Chim. Acta* (2017) 12–24, <https://doi.org/10.1016/j.aca.2017.06.033>.
- [23] A. Zhakupbekova, N. Baimatova, B. Kenessov, A critical review of vacuum-assisted headspace solid-phase microextraction for environmental analysis, *Trends Environ. Anal. Chem.* (2019) e00065, <https://doi.org/10.1016/j.teac.2019.e00065>.
- [24] A. Ghiasvand, F. Yazdankhah, B. Paull, Heating-, Cooling- and vacuum-assisted solid-phase microextraction (HCV-SPME) for efficient sampling of environmental pollutants in complex matrices, *Chromatographia* 4 (2020) 531–540, <https://doi.org/10.1007/s10337-020-03869-0>.
- [25] E. Psillakis, A. Mousouraki, E. Yiantzi, N. Kalogerakis, Effect of Henry's law constant and operating parameters on vacuum-assisted headspace solid phase microextraction, *J. Chromatogr. A* (2012) 55–60, <https://doi.org/10.1016/j.chroma.2012.05.006>.
- [26] M.J. Trujillo-Rodríguez, V. Pino, J.L. Anderson, Magnetic ionic liquids as extraction solvents in vacuum headspace single-drop microextraction, *Talanta* (2017) 86–94, <https://doi.org/10.1016/j.talanta.2017.05.021>.
- [27] H.H. Jelen, A. Gaca, M. Marcinkowska, Use of sorbent-based vacuum extraction for determination of volatile phenols in beer, *Food Anal. Methods* 11 (2018) 3089–3094, <https://doi.org/10.1007/s12161-018-1277-z>.
- [28] P. Fuchsmann, M. Tena Stern, P. Bischoff, R. Badertscher, K. Breme, B. Walther, Development and performance evaluation of a novel dynamic headspace vacuum transfer "In Trap" extraction method for volatile compounds and comparison with headspace solid-phase microextraction and headspace in-tube extraction, *J. Chromatogr. A* (2019) 60–70, <https://doi.org/10.1016/j.chroma.2019.05.016>.
- [29] N. Solomou, C. Bicchì, B. Sgorbini, E. Psillakis, Vacuum-assisted headspace sorptive extraction: theoretical considerations and proof-of-concept extraction of polycyclic aromatic hydrocarbons from water samples, *Anal. Chim. Acta* (2020) 100–107, <https://doi.org/10.1016/j.aca.2019.10.050>.
- [30] E. Yiantzi, K. Murtada, K. Terzidis, J. Pawliszyn, E. Psillakis, Vacuum-assisted headspace thin-film microextraction: theoretical formulation and method optimization for the extraction of polycyclic aromatic hydrocarbons from water

- samples, *Anal. Chim. Acta* (2022) 339217, <https://doi.org/10.1016/j.aca.2021.339217>.
- [31] S.L. Thomas, C. Myers, K.A. Schug, Comparison of fragrance and flavor components in non-psilocybin and psilocybin mushrooms using vacuum-assisted headspace high-capacity solid-phase microextraction and gas chromatography-mass spectrometry, *Adv. Sample Prep.* (2023) 100090, <https://doi.org/10.1016/j.sampre.2023.100090>.
- [32] E. Psillakis, E. Yiantzi, L. Sanchez-Prado, N. Kalogerakis, Vacuum-assisted headspace solid phase microextraction: improved extraction of semivolatiles by non-equilibrium headspace sampling under reduced pressure conditions, *Anal. Chim. Acta* (2012) 30–36, <https://doi.org/10.1016/j.aca.2012.01.019>.
- [33] E. Psillakis, N. Koutela, A.J. Colussi, Vacuum-assisted headspace single-drop microextraction: eliminating interfacial gas-phase limitations, *Anal. Chim. Acta* (2019) 9–16, <https://doi.org/10.1016/j.aca.2019.09.056>.
- [34] E. Psillakis, The effect of vacuum: an emerging experimental parameter to consider during headspace microextraction sampling, *Anal. Bioanal. Chem.* (2020) 5989–5997, <https://doi.org/10.1007/s00216-020-02738-x>.
- [35] G. Wedler, H.-J. Freund, *Lehrbuch der physikalischen Chemie*, John Wiley & Sons, 2012.
- [36] R. Sander, Compilation of Henry's law constants (version 5.0.0) for water as solvent, *Atmos. Chem. Phys.* (2023) 19(2023) 10901–12440, <https://doi.org/10.5194/acp-23-10901-2023>.
- [37] J.M. Prausnitz, R.N. Lichtenthaler, E.G. De Azevedo, *Molecular Thermodynamics of Fluid-Phase Equilibria*, Pearson Education, 1998.
- [38] J.I. Carrero, Beyond Henry's law in the gas-liquid equilibrium, *ChemTexts* (2021) 1, <https://doi.org/10.1007/s40828-021-00153-y>.
- [39] Merck. <https://www.sigmaaldrich.com>. (Accessed 27 January 2026).
- [40] SKC Europe. <https://www.skcltd.com/>. (Accessed 27 January 2026).
- [41] D.M. Ruthven, *Principles of Adsorption and Adsorption Processes*, John Wiley & Sons, 1984.
- [42] P.S.H. Henry, Diffusion in absorbing media, *Proc. R. Soc. A* (1939) 215–241, <https://doi.org/10.1098/rspa.1939.0062>.
- [43] R.M. Barrer, J.A. Barrie, J. Slater, Sorption and diffusion in ethyl cellulose. Part III. Comparison between ethyl cellulose and rubber, *J. Polym. Sci.* (1958) 177–197, <https://doi.org/10.1002/pol.1958.1202711515>.
- [44] D.R. Paul, Gas sorption and transport in glassy polymers, *Ber. Bunsenges. Phys. Chem.* (1979) 294–302, <https://doi.org/10.1002/bbpc.19790830403>.
- [45] J. Pawliszyn, *Handbook of Solid Phase Microextraction*, Elsevier, 2011.
- [46] P. Fuchsmann, F. Wahl, P. Bischoff, *International Patent: Dynamic Headspace Vacuum Transfer "In Trap" Extraction Method and Apparatus*, 2020. Switzerland.
- [47] L.K. Tintrop, M. Meola, M.T. Stern, M. Haueter, N. Shani, H. Berthoud, B. Guggenbühl Gasser, P. Fuchsmann, Analytical mapping of Swiss hard cheese to highlight the distribution of volatile compounds, aroma, and microbiota, *J. Agric. Food Chem.* (2025), <https://doi.org/10.1021/acs.jafc.4c10980>.
- [48] D. Kurpan, X. Gao, R. Cardeiras, M. Bagnoud-Velásquez, L.K. Tintrop, C. Rhème, C. Brügger, A. Blanco Doval, R. Portmann, L. Egger, F. Wahl, A. Baumeyer Brahier, Mechanical cell disruption of the green microalga chloroidium saccharophilum: effects on protein digestibility and aroma profile. <https://doi.org/10.1007/s10811-025-03732-5>, 2025.
- [49] H.Y. Meng, M. Piccand, P. Fuchsmann, S. Dubois, A. Baumeyer, M. Tena Stern, U. von Ah, Formation of 3-Methylbutanal and 3-Methylbutan-1-ol Recognized as Malty during Fermentation in Swiss Raclette-Type Cheese, Reconstituted Milk, and de Man, Rogosa, and Sharpe Broth, *J. Agric. Food Chem.* (2021) 717–729, <https://doi.org/10.1021/acs.jafc.0c06570>.
- [50] L.K. Tintrop, M.A. Jochmann, T. Beesley, M. Küppers, R. Brunstermann, T. C. Schmidt, Optimization and Automation of Rapid and Selective Analysis of Fatty Acid Methyl Esters from Aqueous Samples by Headspace SPME Arrow Extraction Followed by GC-MS/MS Analysis, vol. 22, 2022, pp. 6473–6483, <https://doi.org/10.1007/s00216-022-04204-2>.
- [51] P. Fuchsmann, M. Tena Stern, L.H. Münger, G. Pimentel, K.J. Burton, N. Vionnet, G. Vergères, Nutrivolatilomics of urinary and plasma samples to identify candidate biomarkers after cheese, milk, and soy-based drink intake in healthy humans, *J. Proteome Res.* (2020) 4019–4033, <https://doi.org/10.1021/acs.jproteome.0c00324>.
- [52] V. Somerville, H. Berthoud, R.S. Schmidt, H.-P. Bachmann, Y.H. Meng, P. Fuchsmann, U. von Ah, P. Engel, Functional strain redundancy and persistent phage infection in Swiss hard cheese starter cultures, *ISME J.* (2022) 388–399, <https://doi.org/10.1038/s41396-021-01071-0>.
- [53] H. Zia, U. Von Ah, Y.H. Meng, R. Schmidt, J. Kerler, P. Fuchsmann, Biotechnological formation of dairy flavor inducing δ -lactones from vegetable oil, *Food Chem. X* (2022) 100220, <https://doi.org/10.1016/j.fochx.2022.100220>.
- [54] C. Kast, M. Fracheboud, P. Fuchsmann, Quantitation of 1,4-Dichlorobenzene and thymol in beeswax using dynamic headspace vacuum transfer in trap extraction prior to gas chromatography-mass spectrometry, *Molecules* (2022), <https://doi.org/10.3390/molecules27175367>.
- [55] U. Büttikofer, R. Badertscher, C. Blaser-Freiburghaus, P. Fuchsmann, M. Tena Stern, P.A. Kuert, G. Pimentel, K.J. Burton-Pimentel, N. Vionnet, G. Vergères, Serum and urine metabolites in healthy men after consumption of acidified milk and yogurt, *Nutrients* (2022) 4794, <https://doi.org/10.3390/nu14224794>.
- [56] H.Y. Meng, J. Kim, C. Fleuti, P. Fuchsmann, S. Polakof, D. Dardevet, C. Marmonier, K.J. Burton-Pimentel, U. Büttikofer, G. Vergères, Age-dependent serum volatilomics of milk and yogurt intake: a randomized crossover study in healthy young and older men, *J. Proteome Res.* (2023) 1201–1212, <https://doi.org/10.1021/acs.jproteome.2c00674>.
- [57] T. Roder, G. Pimentel, P. Fuchsmann, M.T. Stern, U. von Ah, G. Vergères, S. Peischl, O. Brynildsrud, R. Bruggmann, C. Bär, Scoary2: rapid association of phenotypic multi-omics data with microbial pan-genomes, *Genome Biol.* (2024) 93, <https://doi.org/10.1186/s13059-024-03233-7>.
- [58] J. Eichinger, A.-M. Reiche, F. Dohme-Meier, P. Fuchsmann, Optimization of volatile organic compounds sampling from dairy cow exhaled breath using polymer-based solid-phase extraction cartridges for gas chromatographic analysis, *J. Breath Res.* (2024) 036001, <https://doi.org/10.1088/1752-7163/ad38d5>.
- [59] C. Wüthrich, A. Vadakkechira, P. Fuchsmann, S. Wacker, R. Zenobi, S. Giannoukos, Comparative analysis of feature annotation methods for SESI-HRMS in exhaled breath analysis, *J. Chrom. A* (2024) 465296, <https://doi.org/10.1016/j.chroma.2024.465296>.
- [60] J. Eichinger, A.M. Reiche, A. Münger, L. Eggenschwiler, G. Pimentel, P. Fuchsmann, K. Huber, F. Dohme-Meier, Usability of volatile organic compounds from exhaled breath compared with those from ruminal fluid, serum, urine, and milk to identify diet-specific metabolite profiles in lactating dairy cows, *J. Dairy Sci.* (2025) 1474–1494, <https://doi.org/10.3168/jds.2023-24579>.
- [61] J. Eichinger, A.M. Reiche, P. Fuchsmann, L. Eggenschwiler, A. Münger, K. Huber, F. Dohme-Meier, Pathway mapping of exhaled volatile organic compounds associated with blood and ruminal fluid metabolites to describe the nutritional and metabolic status of lactating dairy cows, *J. Dairy Sci.* (2025) 2947–2963, <https://doi.org/10.3168/jds.2024-25390>.
- [62] S. Christensen, D. Biedermann, Z. Sattari, T. Roder, Tena-Stern, M. Blaser, C. Fuchsmann, P. von Ah, U. Walther, B. Bruggmann, R. Ganai-Vonarburg, S. C. Vergères, G. Pimentel, C. G. Bär, Metabolic profiling reveals enrichment of health-related metabolites in yogurt by variation of strain consortium, *Food Biosci.* (2025) 107047, <https://doi.org/10.1016/j.fbio.2025.107047>.
- [63] M. Dreier, L. Bettera, H. Berthoud, P. Fuchsmann, L.K. Tintrop, H.-P. Bachmann, D. Guggisberg, R.S. Schmidt, How raw milk-based adjunct cultures influence microbial diversity in cheese, *Int. Dairy J.* (2025) 106249, <https://doi.org/10.1016/j.idairyj.2025.106249>.
- [64] J. Eichinger, L.K. Tintrop, R. Siegenthaler, A.-M. Reiche, F. Dohme-Meier, P. Fuchsmann, Comparison of the suitability of different sampling techniques for exhaled volatile organic compounds in dairy cows, *J. Breath Res.* (2025) 046009, <https://doi.org/10.1088/1752-7163/ae0fbb>.
- [65] E. Rivera-Sánchez, S. Villaró-Cos, M. Salinas-García, F.J. Alarcón, M. García-Vaquero, L.K. Tintrop, D. Kurpan, T. Lafarga, Effect of salinity on the composition of a seawater-adapted strain of *Scenedesmus almeriensis*, *New Biotechnol.* (2025) 114–121, <https://doi.org/10.1016/j.nbt.2025.09.008>.
- [66] Eichinger, J. Reiche, A. M. Eggenschwiler, L. Tretola, M. Pinotti, L. Tintrop, L. K. Fuchsmann, P. Huber, K. Dohme-Meier, F., Exhaled aldehydes as promising compounds to describe the energy balance of lactating dairy cows on a fresh herbage-based diet, *JDS Commun.* <https://doi.org/10.3168/jdsc.2025-0809>.
- [67] C. Marina-Montes, S. Villaró-Cos, L.K. Tintrop, D. Kurpan, F.J. Alarcón, M. García-Vaquero, T. Lafarga, Physicochemical Characterisation of Microalgal Biomass: Paving the Way for Industrial Exploitation, vol. 5, 2026, p. 809.
- [68] L.K. Tintrop, D. Zbinden, M.-C. Risse, P. Fuchsmann, Evaluation and optimization of SPE pre-processing combined with V-ITEX-GC-MS versus direct V-ITEX-GC-MS for urinary volatilome profiling, *Anal. Bioanal. Chem.* (2026) 1–19, <https://doi.org/10.1007/s00216-026-06469-3>.
- [69] H. Piri-Moghadam, M.N. Alam, J. Pawliszyn, Review of geometries and coating materials in solid phase microextraction: opportunities, limitations, and future perspectives, 42–65, <https://doi.org/10.1016/j.aca.2017.05.035>, 2017.
- [70] A. Helin, T. Rönkkö, J. Parshintsev, K. Hartonen, B. Schilling, T. Läubli, M.-L. Riekkola, Solid phase microextraction arrow for the sampling of volatile amines in wastewater and atmosphere, 56–63, <https://doi.org/10.1016/j.chroma.2015.11.061>, 2015.
- [71] I. Bruheim, X. Liu, J. Pawliszyn, Thin-Film Microextraction, vol. 4, 2003, pp. 1002–1010, <https://doi.org/10.1021/ac026162q>.
- [72] H. Piri-Moghadam, E. Gionfriddo, J.J. Grandy, M.N. Alam, J. Pawliszyn, Development and validation of eco-friendly strategies based on thin film microextraction for water analysis, 20–30, <https://doi.org/10.1016/j.chroma.2018.10.026>, 2018.
- [73] M.E. Escuderos, M. Uceda, S. Sánchez, A. Jiménez, Instrumental Technique Evolution for Olive Oil Sensory Analysis, vol. 5, 2007, <https://doi.org/10.1002/ejlt.200600239>, 536–546.
- [74] H.L. Lord, W. Zhan, J. Pawliszyn, Fundamentals and Applications of Needle Trap Devices: a Critical Review, vol. 1, 2010, pp. 3–18, <https://doi.org/10.1016/j.aca.2010.06.020>.
- [75] Royal Society of Chemistry, ChemSpider: search and share chemistry. <https://www.chemspider.com/>. (Accessed 6 January 2026).
- [76] I. Bytheway, M.G. Darley, P.L.A. Popelier, The calculation of polar surface area from first principles: an application of quantum chemical topology to drug design, *ChemMedChem* (2008) 445–453, <https://doi.org/10.1002/cmdc.200700262>.
- [77] F. Pena-Pereira, W. Wojnowski, M. Tobiszewski, AGRE—Analytical GREENness metric approach and software, *Anal. Chem.* (2020) 10076–10082, <https://doi.org/10.1021/acs.analchem.0c01887>.
- [78] W. Wojnowski, M. Tobiszewski, F. Pena-Pereira, E. Psillakis, AGREeprep – analytical greenness metric for sample preparation, *Trends Anal. Chem.* (2022) 116553, <https://doi.org/10.1016/j.trac.2022.116553>.
- [79] M. Tobiszewski, A. Mechlińska, J. Namieśnik, Green Analytical Chemistry—Theory and Practice, vol. 8, 2010, pp. 2869–2878, <https://doi.org/10.1039/B926439F>.
- [80] L.K. Tintrop, A. Salemi, M.A. Jochmann, W.R. Engewald, T.C. Schmidt, Improving greenness and sustainability of standard analytical methods by microextraction techniques: a critical review, *Anal. Chim. Acta* (2023) 341468, <https://doi.org/10.1016/j.aca.2023.341468>.